



**US Army Corps
of Engineers®**
Walla Walla District

**MILL CREEK FLOOD CONTROL PROJECT
OPERATIONS AND MAINTENANCE**

**DRAFT
ENVIRONMENTAL IMPACT STATEMENT
SUPPLEMENT I**

**APPENDIX A
WATER CONTROL MANUAL FOR
MILL CREEK FLOOD CONTROL PROJECT**

May 2018

**Draft Mill Creek Project Flood Control Project Operations and
Maintenance
Environmental Impact Statement**

**Appendix A – Water Control Manual for the Mill Creek Flood
Control Project**

WATER CONTROL MANUAL
FOR
MILL CREEK FLOOD CONTROL PROJECT
WALLA WALLA, WASHINGTON

U.S. ARMY CORPS OF ENGINEERS
WALLA WALLA DISTRICT

JULY 2006

Mill Creek Flood Control Project



NOTICE TO USERS OF THIS MANUAL

Regulations specify that this Water Control Manual be published in loose-leaf form, and only those sections, or parts thereof; requiring changes will be revised and printed. Therefore, this copy should be preserved in good condition so that inserts can be made to keep the manual current.

As a continuing program, it will be necessary to revise portions of this manual annually in order to keep it up to date. Revisions to this manual will be made by the Walla Walla District's Engineering Division (Hydrology Section). Whenever revisions are necessitated, new pages containing the revised material will be printed with the date of revision and issued to each person having a copy of the manual so that substitution may be made.

EMERGENCY REGULATION ASSISTANCE PROCEDURES

In the event that unusual or emergency regulation conditions arise during duty and non-duty hours, contact should be made by telephone to one or more of the following persons in the order given.

Corps of Engineers
Mill Creek Project Office, Walla Walla, Washington

Steve Thompson
Project Manager Office 509-527-7161

Corps of Engineers
Mill Creek Project Office, Walla Walla, Washington

John Heitstuman
Chief, Hydrology Section Office 509-527-7293

Ed Kim
Reservoir Regulation Office 509-527-7289

National Weather Service (NWS)
Northwest River Forecast Center (RFC), Portland, Oregon

Harold Opitz (Hydrologist in Charge)
Donald Laurine (Deputy Hydrologist in Charge / Webmaster)
 Office 503-326-7292

National Weather Service (NWS) Pendleton, Oregon

Marilyn Lohmann (Flood Hydrologist)
Michael Vescio (Meteorologist in Charge)
 Office 541-276-4493

Emergency procedures are used if physical and/or structural failures occur at the Mill Creek Project, and emergency coordination and action may be necessary to prevent loss of life or property. Emergency coordination and action required will be dependent upon the nature and severity of the emergency. Possible emergencies have been divided into the following categories: (1) catastrophic floods, (2) equipment failures, and (3) national type emergencies. The following paragraphs provide guidance on action required by operators and engineers dealing with these emergency conditions.

Catastrophic floods include:

1. Natural flood such as spillway design floods.
2. Flooding and damage caused by earthquakes, cracking, leakage, foundation failures, sabotage, and equipment malfunction, which include the following:
 1. A flood on Russell Creek caused by an embankment failure of the storage dam.
 2. A flood on Mill Creek caused by:
 - (a) An embankment failure of the diversion dam dike.
 - (b) A mechanical failure of equipment at the reservoir intake headworks.

Mitigation efforts for catastrophic floods should be handled according to existing criteria within the “Emergency Action Plan – Mill Creek Project, Walla Walla, Washington, U.S. Army Corps of Engineer, Walla Walla District, August 2000.”

The report and repair of equipment failures that would prevent the controlled discharge of water passing through the reservoir intake headworks, the downstream diversion works, and the storage dam outlet works should be coordinated through the Walla Walla District, Operations Division.

Disasters or circumstances that create national and/or state emergencies create a special operating environment and should be handled according to Walla Walla District’s “Continuity of Action Plan” NWW 500-1-11. Most notable is the possible need to relocate operations and maintain communications.

MILL CREEK FLOOD CONTROL PROJECT

U.S. ARMY CORPS OF ENGINEERS
WALLA WALLA DISTRICT
JANUARY 2006

TABLE OF CONTENTS

	<u>Page</u>
Photograph	i
Notice to users of manual	ii
Emergency regulation assistance procedures.....	iii
PERTINENT DATA	
General.....	A
Diversion works.....	A
Debris facilities.....	B
Intake canal facilities	B
Off-stream storage reservoir	C
Storage dam	C
Outlet works.....	D
Outlet canals.....	D
Division works.....	E
Improved channel.....	E
Hydrologic data.....	F

TEXT OF MANUAL

<u>Paragraph</u>	<u>Title</u>	<u>Page</u>
------------------	--------------	-------------

I - INTRODUCTION

1-01.	Authorization.....	1-1
1-02.	Purpose and Scope.....	1-1
1-03.	Related Manuals and Reports.....	1-1
1-04.	Project Owner and Operator.....	1-2
1-05.	Regulating Agencies.....	1-2
1-06.	Procedures to Update and Revise the Water Control Manual.....	1-2

II - DESCRIPTION OF PROJECT

2-01.	Location.....	2-1
2-02.	Project Purpose.....	2-1
2-03.	Physical Components	

II - DESCRIPTION OF PROJECT (continued)

a.	Main Diversion Works	2-2
	(1) Diversion Dam.....	2-2
	(2) Diversion Dam Dike	2-3
	(3) Intake Canal Headworks	2-3
	(4) Fish Screens	2-3
	(5) Debris Facilities	2-3
b.	Off-Stream Storage Reservoir	2-4
c.	Storage Dam.....	2-4
d.	Outlet Works.....	2-4
	(1) Intake Tower	2-4
	(2) Piping and Water Control Valves.....	2-4
e.	Outlet Canals.....	2-5
	(1) Mill Creek Return Canal	2-5
	(2) Russell Creek Outlet Canal	2-5
f.	Division Works	2-6
	(1) 1st Division Works	2-6
	(2) 2nd Division Works	2-6
g.	Mill Creek Improved Channel.....	2-7
	(1) Upstream Channel Section.....	2-7
	(2) Concrete Channel Section.....	2-7
	(3) Downstream Channel Section	2-8
2-04.	Public Use Areas	
	a. Bennington Lake	2-8
	b. Rooks Park.....	2-9
	c. Mill Creek Recreation Trail	2-9
	d. Public Wildlife Area	2-9
2-05.	Real Estate Acquisition	2-9

III - HISTORY OF THE PROJECT

3-01.	Project Authorization	3-1
3-02.	Construction	
	a. Background.....	3-1
	b. Project Works	3-1
3-03.	Modifications to Regulation.....	3-4
3-04.	Reservoir Seepage	3-5

IV - WATERSHED CHARACTERISTICS

4-01.	Basin Description	
	a. Walla Walla River Basin	4-1
	b. Mill Creek Basin	4-1
4-02.	Geology and Soils	
	a. Regional Geology.....	4-2
	b. Site Geology.....	4-2
4-03.	Sediment	
	a. Diversion Dam	4-2
	b. Reservoir	4-3
4-04.	Climate	
	a. Regional	
	(1) General.....	4-3
	(2) Temperature	4-3
	(3) Precipitation	4-3
	(4) Humidity	4-4
	(5) Analysis of Regional Climate	4-4
	b. Mill Creek Basin	
	(1) General.....	4-4
	(2) Temperature	4-4
	(3) Precipitation	4-4
	(4) Humidity	4-5
	(5) Wind.....	4-5
	(6) Analysis of Basin Climate	4-6
4-05.	Stream Gages.....	4-6
4-06.	Storms and Floods	
	a. General	4-6
	b. Historical Floods	4-6
	c. Standard Project Flood	4-8
4-07.	Runoff Characteristics	
	a. General	4-8
	b. Runoff Contribution and Distribution	4-9
4-08.	Water Quality	4-9
4-09.	Channel and Floodway Characteristics	4-10
	a. Diversion Dam Forebay	4-10
	b. Mill Creek	
	(1) Upstream Channel Section.....	4-10
	(2) Concrete Channel Section.....	4-10
	(3) Downstream Channel Section.....	4-10
	c. Yellowhawk and Garrison Creeks.....	4-10
4-10.	Economic Data	
	a. Population.....	4-11
	b. Agriculture.....	4-11
	c. Industry.....	4-11
	d. Flood Damages.....	4-11

V - DATA COLLECTION AND COMMUNICATION NETWORKS

5-01. Data Collection

- a. General 5-1
- b. Stream Gages..... 5-1
- c. Project Gages
 - (1) Diversion Dam Forebay Gage 5-1
 - (2) Intake Canal Sloping Staff Gage..... 5-1
 - (3) Reservoir Gage..... 5-1

5-02. Communication Facilities and Reports

- a. Communication Facilities..... 5-2
- b. Reports..... 5-2

VI - HYDROLOGIC FORECAST

6-01. General 6-1

6-02. Flood Forecast

- a. Responsibilities of Staff Level Offices..... 6-1
 - (1) Hydrology Branch..... 6-1
 - (2) National Weather Service (NWS)..... 6-1
- b. Estimating Peak Discharges 6-1

VII - WATER CONTROL PLAN

7-01. General Objectives 7-1

7-02. Operating Constraints

- a. Reservoir Floodwater Evacuation 7-1
- b. Outlet Operation 7-1
 - (1) Opening Outlet..... 7-1
 - (2) Closing Outlet 7-2
- c. Russell Creek Outlet Channel Use 7-2
- d. Yellowhawk - Garrison Canal Gage Height Limitations 7-2

7-03. Flood Control Plan

- a. General 7-2
- b. Flood Period 7-3
- c. Flood Diversions 7-3
- d. Change of Regulation Objective 7-3
- e. Flood Control Operation..... 7-3
- f. Evacuation of Bennington Lake 7-5

7-04. Conservation Plan..... 7-5

7-05. Irrigation Plan..... 7-6

7-06. Standing Instructions

- a. Normal Conditions 7-6

VII - WATER CONTROL PLAN (continued)

	(1) Debris Removal	7-6
	(2) Diversion Dam Forebay Area Maintenance	7-6
	(3) Operation and Maintenance Equipment.....	7-7
	b. Emergency Conditions	7-8
	c. Communication Outage.....	7-8
7-07.	Water Quality	7-8
7-08.	Fish and Wildlife	7-8
7-09.	Water Control Plan.....	7-9

VIII - EFFECT OF WATER CONTROL PLAN

8-01.	General	8-1
8-02.	Specific Frequency Lake Elevation.....	8-1
8-03.	Flood Frequencies	8-1

IX - WATER CONTROL MANAGEMENT

9-01.	General	9-1
9-02.	Corps of Engineers	
	a. Planning Division	9-1
	b. Operations Division.....	9-1
	c. Responsibilities of Project Manager.....	9-2
9-03.	Flood Control District	9-2
9-04.	Watermaster.....	9-2
9-05.	Communications.....	9-2
9-06.	Public Information.....	9-2
9-07.	Cooperative Stream Gaging Program with USGS	9-3

FIGURES

4-1	Regional Temperatures (1971 - 2000).....	4-13
4-2	Regional Precipitation (1971 - 2000).....	4-14
4-3	Project Temperature (1971 - 2000)	4-15
7-1	Bennington Lake - Operational Flow Chart.....	7-10
7-2	Bennington Lake - Project Division Works	7-11

CHARTS

7-1	Bennington Lake - Flood Control Rule Curve	7-12
7-2	Bennington Lake - Drawdown Curve, 1263 to 1212.....	7-13
7-3	Bennington Lake - Drawdown Curve, 1212 to 1187	7-14
9-1	Corps of Engineers – Walla Walla District, Organization Chart	9-4
9-2	Personnel and Phone Numbers	9-5

TABLES

No.

2-1	Reservoir Storage Capacity
2-2	Discharge Rating - Russell Creek Outlet Canal
4-1	Mill Creek Project - Average Regional Temperatures
4-2	Mill Creek Project - Regional Precipitation
4-3	Monthly Precipitation – Mill Creek Dam, WA (455387)
4-4	Monthly Precipitation - Walla Walla WB City, WA (458931)
4-5	Monthly Precipitation – Walla Walla FAA Airport, WA (458928)
4-6	Monthly Precipitation – Walla Walla 13 ESE, OR (358985)
4-7	Monthly Precipitation – Whitman Mission, WA (459200)
4-8	Monthly Precipitation – Dayton 1 WSW, WA (452030)
4-9	Monthly Precipitation – Richland, WA (457015)
4-10	Monthly Precipitation – McNary Dam, WA (455231)
4-11	Monthly Precipitation –Pendleton WSO Airport, OR (356546)
7-1	Discharge Rating Table - Mill Creek at Walla Walla
7-2	Discharge Rating Table - Mill Creek near Walla Walla

PLATES

No.

2-1	Project Location Map (Ref. DM #7, Plate 1, MC-05-15/1)
2-2.1	Mill Creek Land Use Map
2-2.2	Mill Creek Channel - General Plan
2-3.1	Diversion Structure - Plan and Sections
2-3.2	Diversion Dam - Fish Ladder
2-3.3	Diversion Dam Dike
2-3.4	Intake Canal Headworks
2-3.5	Debris Collection Facilities - Location Map
2-3.6	Diversion Dam Spillway - Discharge Curve
2-3.7	Diversion Dam Outlet Sluice Gate - Discharge Curve

PLATES (continued)

No.

- 2-3.8 Intake Canal Headworks - Discharge Curves
- 2-3.9 Intake Canal Rating Curve
- 2-4.1 Reservoir - Topographic Map
- 2-4.2 Reservoir Capacity Curve
- 2-5.1 Storage Dam - General Plan
- 2-5.2 Storage Dam - Cutoff Wall Profile
- 2-6.1 Reservoir Outlet System - Profile, Plan, and Section
- 2-6.2 Outlet Works — Intake Tower
- 2-6.3 Reservoir Outlet - Discharge Curves
- 2-6.4 Outlet Pipe to Upper Valve House
- 2-6.5 Upper Valve House Plan and Sections
- 2-6.6 Outlet Pipe to Lower Valve House
- 2-7.1 Mill Creek Return Canal - Plan and Profile
- 2-7.2 Russell Creek Outlet Canal - Plan and Profile
- 2-7.3 Russell Creek Outlet Canal - Discharge Curve
- 2-8.1 1st Division Works (Mill Creek/Yellowhawk) - Plan and Sections
- 2-8.2 2nd Division Works (Yellowhawk/Garrison) - Plan and Sections
- 2-9 Fish Habitat Rock Placement
- 2-10 Recreational Areas - General Layout

- 4-1 Basin Map
- 4-2 Derivation of Standard Project Flood (Plate 16)
- 4-3 Summary Hydrographs - Mill Creek at Walla Walla
- 4-4 Summary Hydrographs - Mill Creek near Walla Walla

- 7-1 Annual Peak Discharge Frequency Curve

EXHIBITS

No.

- 1-1 Mill Creek Project, Washington - Design Memorandums

MILL CREEK PROJECT
WALLA WALLA, WASHINGTON

PERTINENT DATA

1. GENERAL

Location:

State Washington
County Walla Walla
Stream..... Mill Creek
Miles above Walla Walla, Washington3

Construction:

Dam and appurtenant works completed1942
Owner:..... U.S. Army Corps of Engineers, Walla Walla District
Authorized Purpose:..... Flood Control
Type of Project:.....Off-stream Storage
Real Estate: 556-acres of fee acquisition

2. DIVERSION WORKS

Diversion Dam:

Spillway:

Type.....Ambursen, ogee crest
Length at crest, feet250
Crest elevation1261
Height, feet14
Design discharge, cfs (with Water Surface El. 1268)17,000
Concrete structure top elevation.....1270
Stilling basin length, feet.....24
Stilling basin invert elevation1245

Outlet:

Type..... Radial sluice gate
Size, feet6x8
Number1

2. DIVERSION WORKS (Continued)

Sill elevation.....	1247
Control.....	Manual, with portable engine drive
Maximum allowable discharge, cfs.....	400

Fish Ladder:

Width, feet.....	6.5
Capacity, cfs.....	42
Operating Range elevation.....	1253-1256
Intake Invert elevation.....	1250.25
Exit Invert elevation.....	1245

Stilling Basin:

Length, feet.....	4
Width, feet.....	19.5
Floor elevation.....	1242
End Sill elevation.....	1244

Diversion Dam Dike:

Type.....	Earthfill with heavy gravel face
Crest elevation.....	1270 -1280
Length at crest, feet.....	2,200
Top width, feet....	12
Maximum height, feet.....	23
Design Freeboard (SPF), feet.....	5

3. DEBRIS FACILITIES:

Debris Barriers:

Location.....	Diversion Dam Forebay
Length, feet.....	550
Type.....	Steel crib and cable

Shear Wall:

Location.....	Headworks Intake Canal
Length, feet.....	90
Type.....	Panel

4. INTAKE CANAL FACILITIES:

Headworks:

Type.....	Concrete nonoverflow with radial gates
Gate size, feet.....	8x18

4. INTAKE CANAL FACILITIES (Continued)

Number.....	4
Sill elevation.....	1252
Control.....	Electrical/Manual

Canal:

Intake canal end, elevation	1250
Invert elevation.....	1252
Capacity, cfs	7,000
Intake canal base width, feet	60
Intake canal length, feet	1,800

5. OFF-STREAM STORAGE RESERVOIR

Name	Bennington Lake <u>1/</u>
Maximum pool elevation for flood control	1265
Capacity at El. 1265, acre-feet	8,300
Maximum allowable time for storage above El. 1235 (due to seepage).....	15 days
Capacity at elevation 1235, acre-feet	3,300

6. STORAGE DAM

Type	Earthfill with heavy gravel face
Crest elevation	1270
Length at crest, feet.....	3,200
Top width, feet	20
Height above valley floor, feet	125
Toe of embankment, elevation	1150
Cutoff wall top, elevation	1214
Top of embankment blanket protection, elevation	1270
Maximum width at base	800
Embankment Toe Drains:	
Date 9 wells rehabilitated, year	1979
Drainage discharge header, elevation	1135
CMP manhole diameter, inches	48

1/ For the purpose of continuity with existing Mill Creek Project documents; the use of the term "pool" or "reservoir" is used inter-changeably. The term "lake" is used to designate a geographical body of water.

7. OUTLET WORKS

Intake Tower:

Slide gate, centerline elevation	1179
Intake tower, weir overflow elevation.....	1212
Lower sluice gate, centerline elevation	1189

Beneath Dam:

Type.....	Steel pipe
Diameter, inches.....	42
Length, feet.....	900
Discharge pipe, elevation (varies).....	1147.5 -1181

To Mill Creek Return Canal:

Valve Type	Butterfly Valve
Diameter, inches.....	42
Length, feet.....	460
Invert elevation at discharge end.....	1210

To Russell Creek Canal:

Pipe Diameter, inches.....	36
Length, feet.....	125
Howell-Bunger valve, elevation.....	1147.5

8. OUTLET CANALS:

Mill Creek Return Canal:

Type.....	Trapezoidal
Slope.....	0.0008
Lining	Shotcrete
Hydraulic Capacity, cfs	190
Invert elevation at discharge end.....	1210

Russell Creek Canal:

Type.....	Trapezoidal
Slope.....	0.01
Lining	Concrete
Hydraulic Capacity.....	250
Howell-Bunger Valve elevation.....	1147.5

9. DIVISION WORKS

First Division Works:

Mill Creek:

Gate Type	Vertical lift gate
Size of opening	
Total width of openings, feet.....	97
Height, feet	6
Channel Capacity, cfs.....	3,500
Barrier Height, feet.....	2

To Yellowhawk - Garrison Canal:

Gate Type	Radial lift gate
Total width of openings, feet.....	14
Height, feet	6

Second Division Works:

Yellowhawk Creek:

Gate Type	Ungated
Channel Capacity, cfs.....	60

Garrison Creek:

Gate Type	Slide Gate
Channel Capacity, cfs.....	10

Fish Ladder:

Operating elevations

Width	8
Ladder design capacity, cfs	15
Slope	0
Entrance Invert Elevation.....	1170
Exit Invert Elevation	1170

10. IMPROVED CHANNEL

Gose Street to Mullan Avenue:

Type.....	Riprapped levee
Length, miles	1.9
Capacity, cfs	3,500

Mullan Avenue to Roosevelt Street:

Type.....	Concrete-lined
-----------	----------------

10. IMPROVED CHANNEL (Continued)

Length, miles	2.2
Capacity, cfs	5,400

Roosevelt Street to Diversion Dam:

Type.....	Riprapped levee
Length, miles	2.8
Capacity, cfs	3,500

11. HYDROLOGIC DATA

5-year flood event, natural, cfs	2,000
5-year flood event, regulated, cfs	1,470*
100-year flood event, natural, cfs	7,050
100-year flood event, regulated, cfs.....	3,500
Standard project flood, cfs	11,300
Largest flood, 1931, cfs	6,000
Mill Creek drainage basin above Mill Creek at Walla Walla Stream gage, (square miles)	96

* 1,400 cfs in Mill Creek and 70 cfs in Yellowhawk and Garrison Creeks.

SECTION I - INTRODUCTION

1-01. Authorization. This water control manual has been prepared in accordance with the following regulations:

- ER 1110-2-240, “Water Control Management”, dated 8 October 1982, which assigns to District Engineers the responsibility for development of plans and manuals for operation of reservoirs.
- ER 1110-2-8156, "Engineering and Design - Preparation of Water Control Manuals," dated 31 August 1995, with specification on the format and content of this manual.
- EM 1110-2-3600, "Management of Water Control Systems", dated 30 November 1987.

1-02. Purpose and Scope. The purpose of this manual is to present information pertinent to the regulation of Mill Creek Project and to provide a reference source for personnel responsible for the regulation of the Mill Creek Project. Items discussed within this manual are as follows:

- a. Description of project.
- b. History of project.
- c. Watershed characteristics.
- d. Data collection and communication networks.
- e. Hydrologic forecasts.
- f. Water control plan.
- g. Effect of water control plan.
- h. Water control management.

1-03. Related Manuals and Reports. A list of published design memorandums is provided in Exhibit 1-1 of this manual. The following list outlines manuals and reports that contain information and data pertinent to the operation of Mill Creek Project, Walla Walla, Washington.

- a. Reservoir Regulation Manual, “Mill Creek Flood Control Project,” Walla Walla, Washington, April 1964, Revised November 1967.
- b. Design Memorandum No. 3 – “Rehabilitation Reservoir Outlet Canal to Mill Creek,” June 1973.

- c. Design Memorandum No. 5 – “Project Rehabilitation,” August 1979. Supplement 1, “Fish Passage Facility - Mill Creek,” January 1981, Revised August, 1981.
- d. Design Memorandum No. 6 – “Storage Dam Rehabilitation,” February 1980.
- e. Design Memorandum No. 7 – “Main Channel Rehabilitation,” December 1982.
- f. Emergency Action Plan – Dam Safety Program “Identification, Operation, Repair, Notification, and Inundation Maps – Mill Creek Project, Walla Walla, Washington,” August, 2000.
- g. Inspection Report No. 4 – “Mill Creek Lake, Mill Creek, Washington,” August 1984.

1-04. Project Owner and Operator. The Federal Government owns the Mill Creek Project. The U.S. Army Corps of Engineers, Walla Walla District, Operations Division is responsible for the operation and maintenance of the Mill Creek Project.

1-05. Regulating Agencies. The U.S. Army Corps of Engineers, Walla Walla District, Hydrology Section is responsible for the functional day-to-day water regulation of Mill Creek Project. The Hydrology Section is also responsible for reviewing and updating the Water Control Plan for the regulation of Mill Creek Project. Any deviation of this manual needs to be approved by the Division office.

The U.S. Geological Survey (USGS) has the responsibility of collecting, calibrating, and publishing streamflow and water quality data in the basin.

The Natural Resources Conservation Service (NRCS) Snow Survey monitors snow water content and cumulative precipitation for several stations near the Mill Creek Basin.

The U.S Fish and Wildlife Service (USFWS) provide input to the Corps of Engineers on matters pertaining to the preservation of fish life.

1-06. Procedures to Update and Revise the Water Control Manual. Changes and revisions to this manual will be made by the U.S. Army Corps of Engineers, Walla Walla District, Hydrology Section, as newer or revised techniques of regulation and forecasting are developed. If significant changes occur within the watershed or at the dam which affect water regulation, those changes will be included in a revision of the water control manual. Any change in the manual that affects the authorized purposes of the project or involves a significant deviation from the approved plan must be submitted to Northwestern Division (CENWD) for approval. Walla Walla District (CENWW) will keep a master file, and all revisions will be dated.

SECTION II - DESCRIPTION OF PROJECT

2-01. Location. The following data outlines the location of the Mill Creek Project structures. Plate 2-1 shows the geographical location of the project.

Stream: Mill Creek

Diversion Dam - RM 11.4

Storage Dam and Reservoir - 1.2mi southwest of diversion dam

Division Structure - RM 10.5

Gose Street - RM 4.5

Improved Channel:

Begins - Diversion Dam

Ends - Gose Street

Length - 6.9 miles

Drainage Basin: Mill Creek

Drainage Area: 95.7 sq. miles

State: Washington

County: Walla Walla

Location from nearby communities (approximate road mileage):

3 miles east of Walla Walla

6 miles east of College Place

10 miles south of Dixie

21 miles south of Waitsburg

2-02. Project Purpose. The primary purpose of the Mill Creek Project is to provide the greatest overall protection from floods to the City of Walla Walla and adjacent downstream areas bordering Mill Creek, Yellowhawk Creek, and Garrison Creek. The degree of protection afforded any specific area is related to the potential economic damages, existing channel capacities, and an evaluation of the frequency of expected flooding. Other project functions include fish, wildlife, and recreation. The project achieves flood reduction by diverting flow into Bennington Lake. Water is also diverted into Yellowhawk and Garrison Creeks for irrigation purposes.

In high flow conditions water in Mill Creek reaches the main diversion consisting of a concrete dam and earthen dike. From this point it is either allowed to continue downstream or is diverted into the concrete-lined channel leading to Bennington Lake.

Residual flow continues down Mill Creek through an engineered channel for approximately one mile where it reaches the first division works. Here it is either partially diverted into Yellowhawk Creek or continues on through the city of Walla Walla and ultimately empties into the Walla Walla River. Flow that is diverted into Yellowhawk Creek reaches a second division works where it can be diverted into Garrison Creek. Both Yellowhawk and Garrison Creeks empty into the Walla Walla River.

2-03. Physical Components. The Mill Creek Project consists of two basic parts; a Federal portion and a local portion. The Federal portion is operated and maintained by the Corps of Engineers. Project components include: (a) a main diversion works, (b) an off-stream storage reservoir, (c) a dam, (d) an outlet works, (e) outlet canals, (f) division works, and (g) 0.92 miles of improved Mill Creek channel, which extends from the main diversion works to the first division works. The local portion consists of the balance of the improved Mill Creek channel from the first division structure downstream through Walla Walla to Gose Street and is maintained by the Mill Creek Flood Control District. Plate 2-2.1 shows the general location of the project features for the Federal portion of the project and Plate 2-2.2 shows the general location of the local portion of improved Mill Creek channel. Pertinent data on project features are summarized on pages A-F (blue sheets) of this manual.

a. Main Diversion Works. The main diversion works include a diversion dam (consisting of a spillway, outlet, and fish ladder), diversion dam dike, intake canal headworks with fish screen, intake canal to the off-stream reservoir, and debris facilities. The forebay area of the diversion works is contained by an earth dike, a concrete spillway, and a reservoir intake canal headworks. Studies presented in DM No. 5 – “Project Rehabilitation,” August 1979 indicate that the diversion dam and forebay catchment basin will contain the standard project flood of 11,300 cfs without allowing the flow to bypass the main diversion works.

(1) Diversion Dam. The diversion dam is a reinforced concrete structure constructed on gravels and located at RM 11.4. It consists of a spillway, an outlet, and a fish ladder. The function of the diversion dam is to develop a forebay pool, which provides sufficient hydraulic head for diverting floodwater above 1,400 cfs from Mill Creek into Bennington Lake. Plate 2-3.1 shows the plan for the diversion dam and sections through the spillway and outlet.

(a) Spillway. The spillway is an ungated weir, 250 feet in length, with training walls at each end. The crest of the ogee spillway is El. 1261. The top of the training walls is El. 1270. The spillway is designed to pass 17,000 cfs at forebay El. 1268. The spillway has a short downstream concrete apron with dentates for energy dissipation, and discharges into the improved Mill Creek channel. Plate 2-3.6 shows the diversion dam spillway discharge curve.

(b) Outlet. A low-flow outlet with one 6-foot-wide-by 8-foot-high radial sluice gate is located adjacent and to the left of the spillway in the north gate slot. The sill of the gate is El. 1247. The radial sluice gate is operated either manually or automatically in order to maintain a forebay level anywhere between 1253 and 1256msl. The current parameters are set at 1254.5 and 1255.5 as per the recommendations in the Mill Creek Fish Bypass Plan. This range in water surface provides an optimal discharge for the fish passage through the fish ladder.

The radial sluice gate is used for normal discharges up to 400cfs through the diversion dam. Stage 1 begins when flows become greater than 400cfs. During this stage the sluice gate is closed and the fish ladder is open 6 inches, providing enough flow for fish to safely navigate out of the fish ladder. The forebay pools up behind the division dam until flows cross the spillway; at this point the fish ladder gate is closed. Once flows reach 1000cfs (stage 2) preparatory actions for opening the intake canal gates to the reservoir are completed. Once flows reach 1400cfs (stage 3) discharges greater than 1400cfs are diverted to Bennington Lake. Plate 2-3.7 shows sluice gate rating curves.

(c) Fish Ladder. The fish ladder at the diversion dam is shown on Plate 2-3.2. The fish ladder is located in the south gate slot of the diversion dam outlet. The fish ladder is 6.5 feet wide, 86 feet long and 6 feet high. Flow into the ladder is controlled by a 24-inch-wide by 81-inch-high sluice gate and through seven 12-inch-wide vertical slots with one foot of head differential between pools. The pools are 10 feet long.

The water surface upstream of the diversion dam should be maintained between El. 1253 and El. 1256 when the fish ladder is in use. Hydraulic capacity of the ladder is 42 cfs at El. 1256. When flows exceed 42 cfs, the upstream water surface should be maintained at 1256 by routing additional flow through the 6-foot-wide-by 8-foot-high radial sluice gate. The sluice gate located on the upstream end of the fish ladder is used to close off the ladder when water is being routed over the spillway during a flood.

A stilling basin is located downstream of the north gate outlet channel and the south gate fish ladder. The basin is 19.5 feet wide and 4 feet long. The floor of the basin is at invert El. 1242 and the top of the elevation sill is at El. 1244. The stilling basin dissipates the energy of the water by creating a hydraulic jump, which prevents erosion of the left bank area immediately downstream of the outlet and fish ladder. The stilling basin has a design capacity of 900 cfs, which is significant in case the north outlet gate cannot be closed during a major flood.

(2) Diversion Dam Dike. To the right of the spillway training wall an earth dike extends upstream 2200 feet to higher ground and forms the northern boundary of the diversion dam forebay area. The top of this levee embankment varies in elevation from 1270-1280. Plate 2-3.3 shows the plan, profile, and sections for the diversion dam dike.

(3) Intake Canal Headworks. The intake canal headworks is located immediately upstream of the sluice gate and fish ladder and consists of four 18-foot-wide-by 8-foot-high radial gates. The sill elevation of the intake gates is 1252 feet. The four intake gates are individually raised and lowered manually by a portable power driver. Wire ropes on each side of the gate wind on separate drums mounted on a common shaft when the gate is lifted. This shaft is driven by the output shaft of the self-locking worm gear unit of 30:1 ratio. If any part of the hoisting equipment fails on an intake canal gate, the gate cannot be raised or lowered and will be rendered useless until the problem has been corrected. Regular maintenance should prevent any gate operation failure.

The gates can pass a maximum discharge of 7,000 cfs into the storage reservoir through the intake canal. Plate 2-3.4 shows the plan and section of the intake canal headworks. Plate 2-3.8 shows intake canal headworks discharge rating curves and Plate 2-3.9 shows the intake canal-rating curve.

(4) Fish Screens. There are two large drum fish screens located on the eastern intake gate. The fish screens can pass a maximum discharge of 30 cfs into Bennington Lake and are used whenever water is being diverted to maintain conservation pool. Conservation pool, elevation 1205.0, is only maintained when the irrigation demand allows it. Once irrigation demand increases, the diverted flow into Bennington Lake is stopped and the fish screens are removed from the intake gate and stored on site. Fish screens are also removed during spring runoff in order to divert flood flows to the reservoir during flood operations.

(5) Debris Facilities. Two debris barriers insure performance of the project both at the main diversion works and at the Mill Creek improved channel. The general location of these two debris barriers is shown on Plate 2-3.5. The first debris facility is a steel crib and cable type located in the diversion dam forebay. This debris barrier is 550 feet long and it keeps debris contained in a catchment basin area upstream of the main diversion works. The second debris facility is a steel panel shear wall located at the intake canal headworks. This debris shear wall is 90 feet long and it keeps debris from plugging the trash racks of the intake canal headworks. Proper performance of these debris facilities may require trash removal both during and after a flood event.

b. Off-Stream Storage Reservoir. The maximum pool elevation for flood control is 1265 with a capacity of 8,300 acre-feet and a surface area of 225 acres. Plate 2-2.1 shows the storage reservoir and land use map. Plate 2-4.1 shows a topographic map for the reservoir area. Storage capacity curves and data for Mill Creek reservoir are shown on Plate 2-4.2 and Table 2-1.

c. Storage Dam. The storage dam is a rolled earthfill structure 125 feet high, 3,200 feet long at the crest, and 800 feet wide at the base. The downstream slope is 1V on 3H, and the upstream slope is 1V on 4H. The crest elevation is 1,270 feet and the top width is 20 feet. The storage dam embankment is a homogenous section of loess or silt on a silt and conglomerate foundation. A 2,260-foot-long concrete cutoff wall extending 2 feet into bedrock has been constructed on the upstream toe of the dam. Silt-lime treatment provides a surface seal to the compacted silt fill preventing ingress of surface water into any voids present above the level of the concrete cutoff wall. Plate 2-5.1 shows the general plan for the storage dam and Plate 2-5.2 shows the profile of the storage dam cutoff wall.

d. Outlet Works. The outlet works consists of an intake tower and outlet conduit (piping and valves). Plates 2-6.1 show the profile, plan, and section for the reservoir outlet system. Plate 2-6.2 shows the plan and sections of the outlet works intake tower. Plate 2-6.3 shows the reservoir outlet discharge rating curves.

(1) Intake Tower. The top of the intake tower is at El. 1215.75. The intake tower's main components include a two-way drop inlet, a 54-inch slide gate, and a 4-foot-wide-by 4-foot-high lower sluice gate. The drop inlet's weir crest elevation is 1212 and the drop inlet is screened with a structural steel trash rack that extends from elevation 1215 to 1204. The 54-inch slide gate centerline elevation is 1179. The slide gate is controlled by an electric operated crank which is located on top of the dam and a change over gear unit situated on the upstream slope of the dam. The slide gate's crank stem extends down the upstream slope of the dam from the change over gear unit to the slide gate inside the outlet tower. The lower sluice gate centerline elevation is 1189. The lower sluice gate is operated manually from a gate operator located on top of the intake tower.

Under normal operation, for pool elevations above 1212, water enters the outlet tower through the two-way drop inlet and then through the 54-inch slide gate opening into the 42-inch outlet conduit.

Under emergency conditions and when pool elevations below El. 1212 are required, the reservoir can only be drawn down by passing water into the outlet tower through the lower sluice gate.

(2) Piping and Water Control Valves. A 42-inch concrete cylinder pipe extends 900 feet from the intake tower through the foundation of the dam into a wye bifurcation, which branches to a 42-inch butterfly valve and a 36-inch-diameter steel pipe at the toe of the dam. The butterfly valve is controlled manually from a gear operator mounted on a concrete slab at existing ground El. 1160. From the butterfly valve at invert El. 1147.1, the 42-inch concrete cylinder pipe extends 490 feet into the upper valve house, which discharges water into the Mill Creek return canal. The 42-inch pipe has an invert elevation at the discharge end of 1210. Plate 2-6.4 shows the 42-inch pipe system to the upper valve house. The upper valve house contains a weir and stilling basin. Plate 2-6.5 shows the plan and sections for the upper valve house. From the wye bifurcation, the 36-inch steel pipe extends 125 feet into the lower valve house and to Russell Creek. The lower valve house consists of a 36-inch diameter gate valve and a 36-inch diameter Howell-Bunger valve. The Howell-Bunger valve elevation is 1147.5. Plate 2-6.6 shows the 36-inch outlet pipe system at the lower valve house.

e. Outlet Canals.

(1) Mill Creek Return Canal. The Mill Creek return canal is a 5,889-foot-long shotcrete lined channel with a design capacity of 190 cfs. Plate 2-7.1 shows plan and profile for the Mill Creek return canal. The Mill Creek return canal consists of the following elements:

- (a) Sta 4+45 to 49+90: 4,545-foot-long open channel with 4-foot wide bottom width, 1V on 3H side slopes, and on a .0008 gradient.
- (b) Sta 49+90 to 50+00: 10-foot-long concrete inlet structure (transition) on a .02 gradient.
- (c) Sta 50+00 to 51+25: 125-foot-long corrugated metal pipe (CMP) on a .02 gradient.
- (d) Sta 51+25 to 51+57: 32-foot-long CMP on a .065 gradient.
- (e) Sta 51+57 to 51+71: 14-foot-long eccentric reducer (transition from 72-inch to 54-inch CMP) on a .065 gradient.
- (f) Sta 51+71 to 55+20: 349-foot-long 54-inch CMP on a .065 gradient.
- (g) Sta 55+20 to 55+78: 58-foot-long transition and stilling basin.
- (h) Sta 55+78 to 58+90: 312-foot-long twin 54-inch CMP on a .00025 gradient.
- (i) Sta 58+90 to 63+33: 444-foot-long open channel with 8-foot wide bottom width, 1V on 2H side slopes, and a .00025 gradient. The 4-by 4-foot box culverts at the outlet of the Mill Creek return canal (Sta 63+33.5)

carry reservoir releases into the Mill Creek channel under normal operation of the project.

(2) Russell Creek Outlet Canal. Plate 2-7.2 shows the plan, profile, and typical sections for the Russell Creek outlet canal. The Russell Creek canal is a concrete lined open channel and has a design discharge capacity of about 250 cfs. The outlet canal is 7,300 feet long with 3.5-foot bottom width, 1V on 1.5H side slopes, and on a .01 gradient. Plate 2-7.3 shows the discharge curve for the outlet canal and Table 2-2 shows the discharge rating table for the outlet canal.

Note: Refer to Section VII - Water Control Plan, paragraph 7-02. Operating Constraints.

f. Division Works. The division works consist of a 1st division works on Mill Creek and a 2nd division works on Yellowhawk and Garrison Creeks.

(1) 1st Division Works. The 1st division works is located on Mill Creek at RM 10.5, which is about one mile downstream from the main diversion dam. Components of the 1st division works include the division structure across Mill Creek, the Yellowhawk Creek headworks, and a fish ladder on Mill Creek. Plate 2-8.1 shows the plan and section for the 1st division works.

(a) Mill Creek Division Structure. The division structure is a reinforced concrete structure that is located across Mill Creek at RM 10.5. Its function is to divert flow from Mill Creek into Yellowhawk and Garrison Creeks, which serve as irrigation sources. This division structure consists of four 25-foot-wide-by 2-foot-high lift gates, which are operated from the bridge deck of division structure. These four gates have electrical power and can be individually raised and lowered by project personnel. The sill elevation of the division structure is 1170.0. The top of the lift gates is at El. 1172.1 when the gates are lowered completely onto the sill. The gates can be raised above the bridge deck El. 1177.25 for flood operations. The clear opening through the division structure is 96-foot-wide-by 6-foot-high. Studies presented in DM No. 7 Main Channel Rehabilitation, December 1982 indicate that the channel downstream of the main diversion structure will contain a flow of 3,500 cfs.

(b) Yellowhawk Creek Headworks. Streamflow for irrigation and stockwater is diverted from Mill Creek by the division structure into Yellowhawk Creek through the Yellowhawk Creek headworks. The Yellowhawk Creek headworks are located to the left of the division structure across Mill Creek (left bank of channel). The headworks are a concrete intake structure with one 14-foot-wide-by 6-foot-high radial gate. Wire ropes on each side of the radial gate wind on separate drums mounted on a common shaft when the gate is raised. The intake sill elevation is 1170 and the top of the headworks structure is at El. 1177. The radial gate will be closed during a flood operation. Sloping wood needles seal off two other intakes that are no longer used because of reduced channel capacities on Garrison and Yellowhawk Creeks.

(c) Fish Ladder. A 7.5-foot-wide fish ladder is located in the north (right) bank of channel. Its function is to provide a bypass for fish passage when the division structure's lift gates are in the fully lowered position for the diversion of flows into Yellowhawk and Garrison Creeks. Plate 2-8.1 shows the plan and section of the division works fish ladder. The design capacity of the ladder is 15 cfs with a water surface elevation of 1172 on the upstream

face of the ladder. The 18-inch-wide-by 36-inch-high slide on the upstream side of the ladder is used to close off the ladder either when all the flow in Mill Creek is being diverted into Yellowhawk and Garrison Creeks or during a flood operation.

(2) 2nd Division Works. The 2nd division works is located on Yellowhawk 500 feet downstream of the 1st division works. It consists of a control structure that divides the flow between Yellowhawk and Garrison Creeks. A slide gate on the Garrison arm of the control structure regulates flows into Garrison Creek. Plate 2-8.2 shows the plan of the 2nd division works.

g. Mill Creek Improved Channel. The improved channel begins at Gose Street (Sta 5+60) and extends upstream through the city of Walla Walla for a distance of 6.9 miles to the diversion dam spillway (Sta 370+12). The improved channel's slope averages 65 fpm. The Mill Creek Flood Control District is responsible for maintaining the local portion of the improved channel from Gose Street (Sta 5+60) upstream to the project boundary (Sta 317+70), which is a short distance downstream from the division structure (Sta 320+81). The Corps of Engineers maintains the Federal portion of the improved channel from the project boundary (Sta 317+70) upstream to the diversion dam spillway. Components of the improved channel include an upstream channel section, a concrete channel section, and a downstream channel section.

Note: Refer to DM NO. 7 – “Main Channel Rehabilitation,” December 1982 for details on the Mill Creek improved channel.

(1) Upstream Channel Section. Upstream of the concrete channel from Roosevelt Street (Sta 216+91) to the diversion dam spillway (Sta 370+12), the improved channel is 2.9 miles long. The channel in this reach is trapezoidal with a varying bottom width and 1V on 2H side slope. The gradient of the channel is controlled by concrete capped channel stabilizers across a gravel channel bottom. Levees on both sides of the channel have minimum crest widths of 13 feet and riprapped riverside slopes.

The channel bottom width transitions from 250 feet at Sta 371+12 to 120 feet at Sta 357+00. Between Sta 357+00 and Sta 320+81 (division structure across Mill Creek channel), the channel is 120 feet wide. The concrete-capped stabilizers in this reach are on a 60-foot spacing. Large rocks for fish habitat have been placed in the channel reach from the Sta 320+81 (division works) to Sta 363+80. Plate 2-9 shows the fish habitat rock placement.

Downstream of Sta 320+81 (division structure), the channel bottom width transitions to 70 feet at Sta 317+10 and extends to Sta 275+80. Between Sta 317+70 and 275+80, the stabilizers are on a 70-foot spacing. Between Sta 275+80 and Sta 216+91 (upstream of Roosevelt and end of concrete channel) the channel bottom width varies non-uniformly from 70 feet to 540 feet and the spacing between the stabilizers varies from 50 feet to 205 feet.

Bridges in the upstream reach are listed as follows:

Wilbur Avenue Bridge - Sta 236+10
Three Mile Bridge (Tausick Way Bridge) - Sta 292+20
Footbridge - Sta 363+21

(2) Concrete Channel Section. From Mullan Avenue (Sta 107+05) to Roosevelt Street (Sta 216+91), the channel is concrete-lined, 2.1 miles long, and passes through the central part of Walla Walla, which includes residential, business, and industrial sections. The typical channel section is trapezoidal and consists of vertical sidewalls, a center sloping floor, and a pilot channel. The concrete section for this reach of channel varies in size to conform to the various existing structures. Low flows are carried by a 9-foot wide by 20-inch deep pilot channel, which is located down the center of the channel. Partial width baffles spaced at approximately 60-foot intervals in the pilot channel, assist fish during upstream migration. In sharp curves, guide walls are constructed in the center of the channel. Channel crossings are provided by decked-over

reaches and bridges. Bridges in this reach are listed as follows:

Sixth Avenue Bridge	Sta 120+57
Fifth Avenue Bridge	Sta 124+63
Fourth Avenue Bridge	Sta 128+44
Colville Street Bridge	Sta 147+04
Spokane Street Bridge	Sta 150+79
Palouse Street Bridge	Sta 154.02
Park Street Bridge	Sta 163+90
Otis Street Bridge	Sta 172+80
Merriam Street Bridge	Sta 176+89
Clinton Street Bridge	Sta 185+63
Division Street Bridge	Sta 194+44
Roosevelt Street Bridge	Sta 214+02

(3) Downstream Channel Section. Downstream of the concrete channel from Gose Street (Sta 5+60) to Mullan Avenue (Sta 107+05), the improved channel is 1.9 miles long. The channel in this reach is trapezoidal with a 70-foot bottom width and 1V on 2H side slopes and is contained by riprapped levees on both sides. The levee embankments have a crest width of 12 feet to 13 feet. The gradient of the channel bottom is controlled by concrete-capped stabilizers and sheetpile-riprapped stabilizers across a gravel channel bottom on a 70-foot spacing. Bridges in this reach are listed as follows:

Gose Street Bridge	Sta 5+60
Thirteenth Avenue Bridge	Sta 92+43
Mullan Avenue Bridge	Sta 109+90
Railroad Bridge	Sta 100+00

2-04. Public-Use Areas. Public-use recreational areas for the Mill Creek Project include: (1) Bennington Lake, (2) Rooks Park, (3) Mill Creek Recreation Trail, and (4) public wildlife area. Plate 2-10 shows the general layout of these recreational areas for the project. The Corps of Engineers is responsible for the development and management of the public-use recreational areas for the Mill Creek Project and for operating and maintaining the facilities of the project. The Washington State Department of Game, under a license granted to that agency by the Corps, is responsible for managing all fish and wildlife resources of the project. “The Walla Walla District Recreation Facilities Guide” dated March 1987 provides details on Bennington Lake, Rooks Park, and the Mill Creek Recreation Trail. General information on the project's public-use areas is provided in the following paragraphs:

a. Bennington Lake. Facilities at Bennington Lake include a boat launching ramp, a paved parking lot, a picnic area, and restrooms. The primary recreational activities on Bennington Lake included sport fishing and non-power boating (paddle, sail, and electric power). Rainbow trout are stocked in the reservoir, annually since 1953 by the Washington State Department of Game. This program provides a popular put-and-take reservoir fishery for fishermen. The trout fishery is busiest during the spring and early summer and slows down in the summer with lower reservoir levels and warmer water temperatures. There is very little carryover of trout through the winter into the next spring. The reservoir also supports a popular year-round warm water fishery of bass and crappie, which was started in 1975. Swimming in the reservoir is not a significant activity as there is no designated swimming area.

From October 1988 to October 1990, the lake behind the dam was kept dry, but water could be stored for flood control purposes only. As a result, fishing and other water related recreational use of the reservoir was suspended until measures to control or eliminate the seepage problem were resolved. In October of 1990, the Corps of Engineers decided to reestablish the conservation pool of 1205 for fish, wildlife and recreation purposes. The Corps concluded and recommended that the project could be operated in a safe manner as was done in the past and the dam would be closely monitored.

b. Rooks Park. Rooks Park is located on the north shore of Mill Creek's improved channel and immediately downstream from the diversion dam. The facility has parking for 100 cars, a pressure water system, and restrooms. A footbridge crosses Mill Creek at the park and provides access to service roads and trails leading to Bennington Lake and the surrounding project lands.

c. Mill Creek Recreation Trail. The Mill Creek Recreational Trail is a paved bicycle/hiking path that is approximately 8 feet wide and 2.5 miles long. It extends from Rooks Park to the city limits and parallels the right bank of the improved Mill Creek channel. Entrances are at: (1) the south end of Rooks Park, (2) the Tausick Way bridge, and (3) Cambridge Drive (2 blocks north of the Wilbur Avenue bridge).

d. Public Wildlife Area. The project's public wildlife area consists of 316-acres of land, above the reservoir's conservation pool elevation of 1205, which have been allocated for the management of fish and wildlife resources. This public wildlife area provides year-round habitat for a large variety of game and non-game birds and animals. Public access to the wildlife area land is by foot and horseback via service roads and trails through the brushy meadows surrounding the lake. Hunting of upland game is an important recreational use of the public wildlife area. Firearms are limited to shotguns. Each year the Washington State Department of Game stocks the wildlife area land with ring-necked pheasants during the fall hunting season. These stocked birds, along with a small native population, support a large number of hunter-days. Other recreational uses include upland game field trails, hiking, horseback riding, and bird watching.

2-05. Real Estate Acquisition. A total of 556 acres of fee acquisition land have been acquired for the Bennington Lake project. Land use areas include:

1. Project Structures (102 acres)

2. Recreation (75 acres)
3. Wildlife (316 acres)
4. Bennington Lake at pool El. 1205 (52 acres)

Plate 2-2.1 shows designated land use areas and the project boundary. In addition, a flowage easement for 82 acres outside of the project boundary exists for post construction seepage downstream of the storage dam and along the Russell Creek outlet channel.

SECTION III - HISTORY OF PROJECT

3-01. Project Authorization. Mill Creek Dam and project works were authorized by the Flood Control Act of 1938, Public Law 761, 75th Congress, 28 June 1938. Specific requirements applicable to the main channel of Mill Creek were included in the Flood Control Act of 1941, Public Law 228 (Amendatory), 77th Congress, 18 August 1941.

3-02. Construction.

a. Background. Prior to the 1931 flood, flood control improvements in Mill Creek were accomplished by local interests (city and county governments and individuals). These improvements consisted of intermittent concrete retaining walls bordering both sides of the channel mostly within the city limits of Walla Walla. The need for more adequate flood control became especially apparent after the 1931 flood and continuous retaining walls were completed in 1933. The Mill Creek flood control district was organized in 1935 to assume flood control responsibilities. Between 1935 and 1939, the Mill Creek flood control channel from Gose Street Bridge to Tausick Way Bridge was constructed with Work Progress Administration (WPA) funds. Wire-mesh retained stabilizers were built in the channel bottom.

b. Project Works. The improved channel between the diversion dam and Tausick Way, the division structures for Yellowhawk and Garrison Creeks, the diversion dike and spillway, the intake headworks (control structure) and intake canal, and offshore storage dam were constructed in 1942. Post project modifications are listed in the following tabulation:

Mill Creek Project Improvements

Date	Contract	Contract Name
1943	-----	Constructed toe drainage system approximately 300 feet long and 15 feet deep.
1944	-----	Russell Creek outlet canal (lower valve house to Russell Creek) concrete lined.
1948	WW-05-3/1	Improved channel from Mullan Avenue to Roosevelt Street by lining the invert with concrete.
1949	-----	Plugged 30-inch outfall line and 10-inch interior drain line. Recompacted approximately 500-foot wide reservoir area extending upstream from upstream toe of dam.
1950	-----	Installed 54-by 54-inch outlet sluice gate. Installed additional seepage wells (W-1, W-3, W-6, W-7, W-8)
1951	56-C-193	Starting in 1951 wirebound stabilizers were capped with reinforced concrete.
1956	56-C-193	Construction of gaging station downstream from division structure.

1963	63-C-6	Construction of Rooks Park Recreational Area parking, water system, and comfort stations.
1971	71-C-235	Bituminous Paving, Road and Parking Area
1971	71-C-227	Replacement of wooden plank needle gates by power-operated lift gates at Mill Creek (Yellowhawk-Garrison) division structure.
1972	72-C-241	Road Relocation
1974	74-C-252	Winterize Comfort Station and Irrigation (Rooks Pk)
1975	75-C-150	Installed footbridge at Rooks Park crossing stream channel station 363+21.
1976	76-C-91	Drill Well No. 2 (Rooks Park)
1977	77-C-47	Reservoir Outlet Channel
1977	77-C-83	Electrical Distribution - Underground (Rooks Park)
1977	77-C-181	Irrigation Facilities (Rooks Park)
1977	77-C-227	Mechanical Operations of Diversion Works
1977	77-C-47	Replacement of 30-inch-diameter wye and line connecting 42-inch-diameter discharge line to return channel by 42-inch-diameter butterfly valve and 42-inch-diameter concrete cylinder pipe.
1977	77-C-47	Construction of toe drainage ditch at storage dam.
1977	77-C-47	Return channel to Mill Creek lined with polyvinyl.
1978	78-C-287	Cobble Slope Protection for Mill Creek Extension
1979	79-C-50	Fencing (Mill Creek Reservoir)
1979	79-C-124	Seepage Relief Well Repairs and Manhole Const
1979	79-C-124	Extended and buried 30-inch-diameter outfall line. Installed nine new manholes to facilitate cleanout.
1981	81-C-33	Storage Dam Rehabilitation
1981	81-C-91	Intake Canal Rehabilitation
1981	81-C-121	Construction of fish ladders in the right abutment at the 1st division works and in the south side of the low-flow gate outlet at the diversion dam structure.
1981	81-C-33	Installation of outlet works-intake tower and gate operator stem with support slab at storage dam.

1981	81-C-33	Installation of 2-foot-thick cutoff wall at storage dam.
1983	83-C-59	Lime Treated Silt Embankment Facing
1983	83-C-96	Return Canal Rehabilitation
1983	83-C-112	Minor Rehabilitation of Mill Creek Structures
1983	83-C-121	Phase II Planting
1984	84-C-62	Rehabilitation of Mill Creek Channel - Phase I
1984	84-C-93	Debris Collection Facility
1984	83-C-96	Return channel to Mill Creek lined with shotcrete. New intake slide gate installed at Garrison Creek. The 36-inch gate valve improvement (new bypass line) at Russell Creek outlet valve. Gate seal replacement at intake canal.
1984	DB-84-32	Installation of reservoir elevation gage at storage dam.
1985	85-B-22 / 85-C-33	Rehabilitation of Mill Creek Channel - Phase II
1985	85-C-34	Cleaning of Steel Piling - Mill Creek Channel Rehab
1985	81-C-91	New trash racks installed at all 4 gates of intake canal.
1985	84-C-93	Existing fish ladder replaced with new fish ladder in south sluiceway of diversion dam.
1985	84-C-93	Debris collection facilities - installed shear wall and steel crib barrier system.
1986	86-C-30	Rehabilitation of Mill Creek Channel - Phase III
1986	86-C-30	Paved bicycle path.
1986	86-C-30	Placement of fish habitat stones.
1989	89-C-39	Rooks Park Comfort Station
1989	89-C-39	Master Plan, Vol I, originals
1989	89-C-39	Master Plan, Vol II, section 1, 2, 4
1989	89-C-39	Master Plan, Vol II, section 3
1996	96-B-14 / 96-C-27	Diversion Forebay Silt Removal
1996	96-M-3991	Channel Repair (Equipment Rental)

1996	96-B-26 / 96-C-35	Channel Retaining Wall
1997	97-M-3027	Support Foundation
1997	97-M-3028	Riprap Replacement at Intake Canal W68SBV-6313-GA02
1997	97-B-21 / 97-C-30	Replacement Relief Wells
1999	99-C-16	Exploratory Grouting, Mill Creek Dam, Washington (Contractor Pfm Eval)
2000	00-C-0050	Mill Creek Diversion And Intake Structure Modifications
2001	01-B-11 / 01-C-18	Right Abutment Grouting
2002	02-C-10 / 02-B-04	Mill Creek - Rooks Park Improvements
2002	02-C-18	Right Bank Levee Extention
2003	03-B-11 / 03-C-0021	Mill Creek Rehabilitation

3-03. Modifications to Regulation. The following tabulation summarizes regulation objective changes for the Bennington Lake project as presented in previous documents:

Summary of Regulation Objective Changes

Discharge in cfs					
Source	Passing Diversion Dam	In Mill Creek through Walla Walla	Diverted to		
			Yellowhawk	Garrison	
1	H.D. 578,1938	6,400	5,000	900	500
2	H.D. 578,1938	5,500	4,100	900	500
3	Mill Creek Reservoir Operation Study, Dec 1941	4,600	4,100	300	200
4	Letter of 11 March 1946	3,700	3,200	300	200
5	Interim Report, Mill Cr. in Walla Walla, 1947	5,900	5,400	300	200
6	Manual, 1951	5,735	5,400	275	60
7	Revision of Manual, 1954	2,335 ^{1/}	2,000	275	60
		5,735 ^{2/}	5,400	275	60
8	Revision of Manual, 1964	2,070	2,000	60 ^{3/}	10 ^{3/}
9	Revision of Manual, 1967	1,470	1,400	60 ^{3/}	10 ^{3/}
10	Revision of Manual, 1988	1,470	1,400	<60 ^{4/}	<10 ^{4/}
11	Revision of Manual, 2006	1,470	1,400	<60 ^{4/}	<10 ^{4/}

^{1/} All flow in excess of that permitted to pass diversion dam is to be diverted and stored until Mill Creek Reservoir is filled to capacity.

^{2/} Discharge based on rule curve.

^{3/} Irrigation requirements.

^{4/} No flood control diversions will be made into Yellowhawk and Garrison Creeks during a flood event.

3-04. Reservoir Seepage. The reservoir's seepage problem was first noted after an initial test filling of the reservoir in 1941. Subsequent filling tests on seepage from the reservoir were conducted in 1942, 1945, 1950, 1964-1965 flood, and 1984. Project improvements completed during the 1943-1982 period for seepage have not significantly reduced reservoir seepage.

After the 1945 test filling of the reservoir, a perpetual flowage easement was secured from the Dooley estate providing for permanent right of the Government to cause saturation and inundation due to seepage from the reservoir within an 82-acre area downstream of the storage dam.

The Corps rehabilitated the project in 1983 by constructing a concrete cutoff wall near the upstream toe of the dam to provide a seepage barrier. This wall penetrates through the conglomerate to basalt bedrock 160 feet into the ground.

The test pool raise conducted in 1984 indicated that a seepage condition still existed even after the construction of a 2-foot-thick cutoff wall. The wall reduced seepage by one-third, much less than anticipated.

In 1988, the Corps made a decision to drain the lake for safety purposes, until a thorough investigation of the seepage problem at the dam could be completed and evaluated. From 1988-1989, the Walla Walla District examined various alternatives to reduce seepage, including installation of a polyethylene liner covering the lakebed.

In 1990, the Corps concluded and recommended that the project could be operated in a safe manner as was done in the past without the liner, but that the dam should be closely monitored.

SECTION IV - WATERSHED CHARACTERISTICS

4-01. Basin Description.

a. Walla Walla River Basin. The Walla Walla River originates in the Blue Mountains (El. 6,000 ft msl) and flows through narrow, well-defined canyons out of the mountains, then through broader valleys draining low, rolling wheat lands. The following tabulation summarizes area and runoff data for major tributaries above the Walla Walla River near Touchet gaging station:

Area Distribution And Runoff Contribution
For Walla Walla River
(Water Years 1942 - 2005)

Stream Gage	Drainage Area		Average	Annual
	(Sq. mi)	(%)	Runoff (A.F./Yr.)	Volume (%)
S.F. Walla Walla near Milton, OR. ^{1/}	63	4	127,000	31
N.F. Walla Walla near Milton-Freewater, OR. ^{2/}	34	2	36,370	9
Mill Creek at Walla Walla, WA.	96	6	57,410	14
Touchet River at Bolles, WA. ^{3/}	361	22	163,700	40
Local Runoff	1,103	67	27,220	6
Walla Walla near Touchet, WA.	1,660	100	411,700	100

1/ gage record May 1903 to October 9, 1991
 2/ gage record October 1969 to September 1991
 3/ gage record April 1951 to September 1989

On average 34 percent of the total drainage area above the Walla Walla River near Touchet, WA. gage contributes 92 percent of the total runoff.

b. Mill Creek Basin. Mill Creek originates on the western slopes of the Blue Mountains in southeastern Washington, at an elevation of 5,500 feet, flows for a distance of 15 miles in a relatively deep and narrow canyon through mountainous terrain, and then enters an alluvial plain a few miles east of Walla Walla. The mean elevation of the basin upstream from the reservoir is 3,200 feet. The drainage basin area is 95.7 square miles above Mill Creek at Walla Walla streamgage. The City of Walla Walla is located on the thick alluvial fan of Mill Creek and extends to within approximately one mile of the fan's apex. The chief tributary to Mill Creek is Blue Creek, which drains about 17 square miles of mountainous terrain and joins Mill Creek about eight miles above Walla Walla. Yellowhawk and Garrison Creeks are diverted from Mill Creek about 1.75 miles east of the city limits, and flow in a westerly direction over the southern portion of the Mill Creek fan and eventually drain into the Walla Walla River. Mill Creek enters Walla Walla River about six miles west of the city at RM 33.6. Plate 4-1 is a basin map of the Mill Creek basin and adjacent stream basins.

4-02. Geology and Soils.

a. Regional Geology. The Mill Creek basin is a major subbasin in the Walla Walla River basin. The Walla Walla River basin is located near the boundary between the Blue Mountain and Columbia River Plateau physiographic regions. The Blue Mountains rise to over 6,000 feet to the east and southeast of the basin and the Columbia River Plateau is to the north and west of the Walla Walla River basin. Regional folding around the basin boundary and faulting formed the Walla Walla River basin. Major geological features around the boundary of the basin include: (1) the northeast-southwest trending Blue Mountain anticline which is located along the crest of the Blue Mountains southeast of the basin, and (2) northwest-southeast trending Horse Heaven anticline located southwest of the basin.

The major rock underlying the basin is the Miocene Age (15-20 million years ago) Columbia River Basalt Group. The Columbia River Basalt Group consists of a thick sequence of lava flows known to be in excess of 6,000 feet thick in the Pasco Basin. Individual flows generally range from approximately 50 feet to over 150 feet. Unconsolidated gravels and clays overlie the basalt.

An extensive deposit of windblown silt (loess soil) called the Palouse formation covers most of the Walla Walla basin. This formation eroded and resulted in the gently rolling hills which are typical of the region. Water-laid materials composed of silts and fine sands interlayered with lenses of gravels called the Touchet Beds filled portions of the Walla Walla Basin, particularly in the western area toward the Pasco Basin. Deposits of recent alluvium are found in the river channels.

b. Site Geology. The Mill Creek Dam and Reservoir are located on Prospect Point Ridge, a major geological feature along the eastern boundary of the Walla Walla Basin. This feature is believed to be the result of faulting as interpreted from elevation differences in the bedrock surface as encountered in numerous water wells drilled in the valley (ref. "Geology and Groundwater Resources of the Walla Walla River Basin, Washington-Oregon", by R.C. Newcomb, 1965). Although somewhat irregular due to erosion by streams, the bedrock surface beneath the reservoir and embankment dam slopes approximately 4 to 5 degrees westerly from the left abutment to the right abutment. This slope closely approximates the attitude of the basalt flows exposed in canyons to the east of the project. There are no rock outcrops in the immediate vicinity of the dam. The bedrock is overlain by conglomerate gravels of basaltic origin. The conglomerate varies from a few feet in thickness on the left abutment to as much as 105 feet on the right abutment. The entire reservoir area is mantled by the Palouse silts in varying thicknesses, but the silt forms the entire right abutment of the dam with a thickness of approximately 100 feet.

4-03. Sediment.

a. Diversion Dam. After each high water period on Mill Creek, sediment deposits, vegetation, and debris tend to accumulate in the diversion dam's forebay basin. Sediment deposits in this forebay area can affect gate operation at the intake canal's headworks during

diversion of floodwaters into the reservoir. Since sediment deposition in the forebay basin will be a continuing problem, periodic removal of sediment deposits in the forebay basin will be required.

b. Reservoir. Since 1942, sediments introduced into the reservoir during diversion of floods have not had an appreciable effect on the operation of the project for flood control. However, sediment deposits on the outlet works intake gates are a serious concern because sediment buildup can affect gate operation. Proper maintenance for gate operation will require removal of any sediment buildup on the lower 4 by 4 sluice gate to assure gate operation for reservoir drawdown below El. 1212.

4-04. Climate.

a. Regional.

(1) General. Bennington Lake is located within the Lower Columbia River Basin. The climate in the Lower Columbia River Basin ranges from moist, mild maritime condition near the mouth of the river to a near desert climate in some of the Southeastern Washington valleys. Topography causes striking climatologic variations in the basins, although distance from the ocean is also an important influence. Normal annual precipitation varies from approximately 100 inches over small areas in the Cascade Range to less than 6 inches over portions of the plains area of southeastern Washington. A large portion of the basin normally receives less than 20-inches of precipitation annually. Maximum precipitation occurs during the winter months over most of the Lower Columbia River Basin.

The entire Lower Columbia River Basin is influenced by maritime air and the prevailing westerly winds resulting in relatively mild winters. Occasionally, polar continental air flows into the basin causing short periods of extremely low temperatures. Throughout the basin lower humidity, higher temperatures, less precipitation and more sunshine occur during the summer months than during the winter months.

(2) Temperature. East of the Cascade Range in north central and northeast Oregon and southeast Washington average December-February winter temperatures range from 25°F at El. 5,000 ft to 35°F at 1,000 ft, and average July temperatures similarly ranges from 65°F to 75°F. Temperature extremes well above 100°F have been recorded in the summer, and temperatures of -10°F to -15°F occur occasionally in the winter. Thirty-year average temperatures for monthly and annual maximum, minimum, and mean values are summarized in Table 4-1 (tables are located in the back of the manual) for key climatological stations within the Mill Creek Project Region. Figure 4-1 shows average monthly temperatures for the Mill Creek Project Regional area (Refer to Page 4-13).

(3) Precipitation. The topographic characteristics of the basin have a great influence on the precipitation pattern. The source of moisture for precipitation in the region is the Pacific Ocean. The maritime air masses entering the basin are forced to ascend the Coast and Cascade Ranges causing relatively heavy precipitation on the western slopes and reduced amounts for interior areas from the eastern slopes of the Cascades to the Blue Mountains. Elevations in excess of 5,000 ft receive and retain precipitation in the form of snow in the Lower

Columbia River Basin. Precipitation data for climatological stations within the Mill Creek Project Region is summarized in Table 4-2 in the back of this manual. Figure 4-2 shows the average monthly precipitation for the Mill Creek Project Regional area (Refer to Page 4-14).

(4) Humidity. Generally, when temperatures are above 90°F, relative humidity can usually be expected to be less than 25 percent. Winter air masses and lower temperatures give rise to relative humidity values in the 70 to 80 percent range.

(5) Analysis of Regional Climate. In summary, the climate of the Lower Columbia River Basin is characterized by wet, relative mild, and cold semi-arid winters and warm dry summers. The interior regions of the basin, from the Cascade Mountains to the Blue Mountains, lie in a transition zone between the maritime climate of the Pacific Coast and the continental climate of the Great Plains. The eastern region of the Lower Columbia River Basin is generally semi-arid, with little or no precipitation during the summer growing season and only small amounts of precipitation during the winter. Relative large amounts of precipitation are experienced in the higher elevation areas of the Cascade and Blue Mountain ranges.

b. Mill Creek Basin.

(1) General. The Mill Creek area is characterized by wide seasonal variations in temperature and wide geographical variations in precipitation. Mill Creek Basin is in the belt of prevailing westerly winds and is largely under the influence of air from the Pacific Ocean. Occasionally, polar outbreaks of cold air spill over the Rocky Mountain barrier resulting in short periods of extremely low temperatures, but generally, winters are characteristically damp and foggy.

(2) Temperature. The following paragraphs summarize temperature data for selected climate stations in the Mill Creek Basin.

(a) Walla Walla WB City, WA. (El.948). Average monthly maximum temperatures range from 40°F in January to 88°F in July. Average monthly minimum temperatures range from 28°F in January to 61°F in July and average monthly temperatures range from 34°F in January to 75°F in July. Extreme temperatures range from -16°F to 113°F. The average frost-free period extends from late March through early November and the average growing season is about 220 days.

(b) Walla Walla 13 ESE, OR. (El. 2400). Average maximum monthly temperatures range from 35°F in January to 83°F in July. Average minimum temperatures range from 24°F in January to 47°F in July. Average monthly temperatures range from 30°F in January to 65°F in July.

(c) Refer to figure 4-3 (Page 4-15) and Table 4-1 for additional information.

(3) Precipitation. Mean annual precipitation for climate stations in the basin ranges from 17.8 inches at Walla Walla WB City, El. 948, in the lower portion of the basin, to 41.9 inches at Walla Walla 13 ESE, El. 2,400 (Refer to Tables 4-3 and 4-4). It is probable that at

elevations above 5,000 feet, mean annual precipitation exceeds 50 inches. At Walla Walla, approximately 10 percent of the normal annual precipitation falls as snow; at higher elevations, this percentage is increased considerably, becoming approximately 40 percent at the 5,000-foot level. The normal annual precipitation for the basin is estimated to range from 35 to 40 inches above the project.

Climatological records for stations in and adjacent to the Mill Creek basin are published by the National Oceanic and Atmospheric Administration (NOAA) at the Climatic Data Center, Asheville, North Carolina. The following tabulation lists climate stations in the Mill Creek basin:

	<u>Station</u>	<u>Type</u> ^{1/}	<u>Latitude</u>	<u>Longitude</u>	<u>Elevation</u>
1.	Walla Walla 13 ESE	13	N 46° 0'	W 118° 0'	2400
2.	Mill Creek Dam	12	N 46° 5'	W 118° 16'	1175
3.	Walla Walla FAA AP	13	N 46° 6'	W 118° 17'	1160
4.	Walla Walla WB City	13	N 46° 2'	W 118° 20'	948
5.	Whitman Mission	14	N 46° 3'	W 118° 27'	633

1/: 12 = Precipitation records only
 13 = Temperature and precipitation records
 14 = Temperature, precipitation, and evaporation records.

(4) Humidity. Relative humidity at Walla Walla WB City, WA. (El. 948) is moderate most of the time and averages between 50% and 70% annually. Highest relative humidity, near 100%, occurs generally during periods of fog in late fall and winter. For the December through January period, average monthly relative humidity is about 80% at 4:00 a.m. and 78% at 4:00 p.m. Lowest relative humidity, near 10%, usually occurs in hot summer afternoons. During the summer months, there is considerable diurnal variation in relative humidity values (i.e. the average monthly relative humidity is about 50% at 4:00 a.m. and 22% at 4:00 p.m. in July). Over Bennington Lake and adjacent lands, the relative humidity values would be higher because of water evaporation. Measured at Whitman Mission, WA (El. 633) evaporation data for the period 1971-2000 (30 years) is shown on Table 4-5 and summarized in the following tabulation:

BENNINGTON LAKE - MONTHLY EVAPORATION (Inches)

STATISTICS 1971 - 2000 (30 Years)

	<u>APR</u>	<u>MAY</u>	<u>JUN</u>	<u>JUL</u>	<u>AUG</u>	<u>SEP</u>	<u>TOTAL</u> <u>APR-SEP</u>
MEAN	4.67	6.53	8.20	10.20	9.01	5.43	44.10
MAXIMUM	6.59	8.07	10.33	12.63	10.67	6.76	51.31
MINIMUM	3.58	5.30	6.40	8.19	7.38	4.12	38.08

Source: Climatological Data Annual Summary, Washington.

(5) Wind. The prevailing winds for the Walla Walla area during the day are out of the south. Winds are generally quite light but occasional damaging windstorms and dust storms

have occurred. Average speed varies between 4 to 6 miles per hour. Mornings are generally calm and afternoon winds are generally out of the south and southwest. At night prevailing winds (drainage winds) drift off the Blue Mountains and are out of the southeast. Occurrences of strong winds in excess of 60 miles per hour (mph) for the Walla Walla FAA Airport climate station are summarized as follows:

Date		Maximum Wind Speed (mph)
Month	Year	
December	2002	69
January	1990	69
November	1958	67
March	1987	62

(5) Analysis of Basin Climate. Climate has a profound effect on recreation activities at the Bennington Lake project. Low precipitation during November through February results in below normal spring snowmelt runoff which affects the length of time through the summer that water is available for irrigation uses.

4-05. Stream Gages. Plate 4-1 shows locations of the stream gaging stations in Mill Creek Basin. Records for Mill Creek are published by the U. S. Geological Survey.

Stream and Station	Drainage Area in Square Miles	Period of Record
Mill Creek near Walla Walla	60	Aug 13 - Sep 17 Apr 38 - Sep 38 Oct 39 - Sep 76 Oct 79 - date
Mill Creek at Walla Walla	96	Apr 41 - date

4-06. Storms and Floods.

a. General. Historical floods on this stream and other streams in the region indicate that damaging floods may occur during the period from December through June. Major floods may result from any one of the several following conditions: (a) heavy general rainfall, (b) rainfall plus snowmelt, or (c) "cloudburst" type rainfall. Each of these conditions, within the last 50 years, has produced major floods on streams within 100 miles of the Mill Creek Basin.

b. Historical Floods. Floods of damaging proportions occurred in the Walla Walla area in 1878, 1882, 1889, 1905, 1906, 1907, 1908, 1917, 1922, 1925, 1926, 1927, 1930, 1931, 1932, 1945, 1946, 1948, 1950, 1951, 1953, 1964, 1965, 1969, 1971, 1974, 1975, 1977, 1982, 1986, 1996. Very little is known of the magnitude of the earlier floods listed above.

The largest historical flood for which information is available is that of 1931, with an estimated peak discharge of 6,000 cfs at Walla Walla. This flood occurred on 1 April and was the result of intense rainfall on ground primed for runoff by several days of rain and snowmelt. The estimated snow line for Mill Creek Basin was at 4,500 feet, approximately 20 percent snow

cover, on 31 March. With maximum and minimum temperature of 58 and 49 degrees, respectively, at Walla Walla, El. 900 feet msl, snowmelt contributed only a small portion of the peak discharge. A total of 6.65-inches of rain fell at Kooskooskie from 28 March through 1 April, with the largest 24-hour amount of 3.81 inches falling on 31 March. At the height of the flood the entire Walla Walla business district and a large part of the residential district were flooded. Extensive damage was caused to state and county highways and bridges, railroad roadbeds, and city buildings and streets. Adjacent to the city, losses to farm lands, buildings, and livestock were heavy.

The second highest flood occurred on 9 February 1996. At the beginning of February 1996, the Mill Creek watershed was covered with snow on top of frozen ground. The temperatures were extremely cold with daytime highs of approximately -2 to -25 degrees Fahrenheit. On the 5th and 6th of February, the temperatures increased rapidly to approximately 50 to 60 degrees Fahrenheit and the snow covered ground in the valleys and lower foothills rapidly melted and significantly increased streamflows. On the 8th and 9th of February, the temperatures climbed again as warm rain fell in the amount of 0.5 to 1.25 inches melting higher elevation snowpacks. Mill Creek overflowed its banks upstream of the city of Walla Walla and did major damage to many private homes in the upper basin. The reservoir just upstream of Walla Walla reduced the natural peak from approximately 6,000 CFS to the downstream channel design capacity of 3,500 cfs. The flood operation occurred between 7-9 February and the total volume of water diverted into the reservoir was 6360 acre-feet. The reservoir was filled from elevation 1191 on 7 February to a maximum elevation of 1256.7 feet on 9 February.

The third highest flood known occurred on 30 May 1906. This flood resulted from a heavy rainstorm centering in northeastern Oregon and southern Washington. Maximum recorded precipitation for the four-day storm was 5.18 inches at Weston, Oregon, with 4.29 inches being recorded at Walla Walla. No precipitation records are available for the higher elevations of the basin. If there was any snow on the basin, it was at extreme peaks and contributed little, if any, to the peak discharge. This flood had an estimated discharge of 5,200 cfs at Walla Walla, but the resulting damages were not as great as those experienced in 1931, since the city and vicinity were not so highly developed.

Since the Mill Creek Flood Control Project was constructed in 1941, 27 floods have occurred which would have required regulation under the present plan of regulation. They were as follows:

<u>Date</u>	<u>Natural Peak Discharge</u> (cfs)	<u>Regulated Peak Discharge</u> (cfs)	<u>Hours Duration over 1,400 cfs</u>
1906	5,200		
1931	6,000		
28 Dec 45	2,900	2,700	21
12 Dec 46	1,700	1,600	--
7 Jan 48	1,700	1,480	--
22 Jan 50	1,800	1,730	--
11 Feb 51	1,840	1,810	--
18 Jan 53	1,700	1,630	28
25 Nov 64	1,822	1,750	3
2 Dec 64	1,738	1,320	4
23 Dec 45	3,300	2,400	50
29 Jan 65	2,810	1,660	77
6 Jan 69	3,317	2,330	53
19 Jan 71	1,940	1,340	39
16 Jan 74	1,689	1,430	--
25 Jan 75	2,370	1,600	16
7 Dec 75	2,369	1,500	24
2 Dec 77	1,744	1,400	8
13 Feb 77	1,601	1,420	6
14 Feb 82	2,050	1,730	15
21 Feb 82	1,740	1,580	24
23 Feb 86	2,050	1,359	8
9 Feb 96	6,000	3,800	48
1 Jan 97	2,640	1,640	18
1 Feb 97	2,550	1,650	13
1 Feb 03	2,220	1,500	24
29 Jan 04	1,840	1,590	14

Considerable land inundation occurs along the unimproved reach below Walla Walla when flows exceed 1,700 cfs. These floods have all occurred during the winter season and were caused by rainfall on saturated or frozen ground conditions, with snow cover at high elevations only. Discharge-damage data for the improved channel and natural channel reaches of Mill Creek is listed on Page 4-11.

c. Standard Project Flood. The standard project flood (SPF) is the estimated flood that would result from centering the worst regional rainstorm of record over the Mill Creek drainage area above the dam at a time when the ground was covered with a maximum observed snow cover. The derivation of the SPF is summarized on Plate 4-2. The present SPF is 11,300 cfs.

4-07. Runoff Characteristics.

a. General. The general pattern of streamflow for Mill Creek consists of moderate to high flows from November through June and low flows from July through October. During years of low autumn precipitation and below normal winter temperatures, the period of low

flows may extend as late as February. Major floods may be caused from any one of the following conditions: (1) intensive rainstorms, (2) a combination of rainfall and snowmelt, or (3) summer "cloudburst" thunderstorms. The winter flood period generally extends from December through February. Winter floods are flash-type floods that are relatively short in duration with peak discharges occurring in December through February. Historical floods of damaging magnitudes on Mill Creek have generally occurred in the winter and have been caused primarily by runoff from intense rainfall on snow with frozen ground or ground with a high soil moisture content. The spring snowmelt flood period generally extends from about the first of March through May. Peak discharges from snowmelt only runoff, rarely results in damaging stages. For the 1942-2005 period of record, the maximum mean daily discharge was 1,970 cfs on 23 December 1964 and the minimum mean daily discharge generally reaches zero in August. The largest historical flood outside of this period of record occurred on 1 April 1931 with an estimated peak discharge of 6,000 cfs.

b. Runoff Contribution and Distribution. Plate 4-3 shows Summary Hydrographs for Mill Creek at Walla Walla, Washington gaging station (14015000) at RM 10.5 for water years 1942-2005. Extremes of runoff during this period are 131,800 acre-feet maximum in water year 1974 and 12,900 acre-feet minimum in water year 1977. The mean annual runoff for the 95.7 square miles of drainage above Mill Creek at Walla Walla gaging station for water years 1984-2005 is 59,000 acre-feet. Approximately 98 percent of the total average annual runoff occurs from November to June, 49 percent between November and February and 49 percent between March and June. Daily Discharge Hydrographs for Mill Creek at Walla Walla gaging station can be viewed by visiting the U.S. Geological Survey (USGS) website at http://waterdata.usgs.gov/nwis/dv?referred_module=sw&site_no=14015000 .

Plate 4-4 shows Summary Hydrographs for Mill Creek near Walla Walla, Washington gaging station (14013000) at RM 21.2 for water years 1914-1917, 1940-1976, and 1980-2005. The mean annual runoff for the 59.6 square miles of drainage above Mill Creek near Walla Walla gaging station for the period of record through water year 2005 is 69,290 acre-feet. Approximately 88 percent of the total average annual runoff occurs from November to June, 41 percent between November and February and 47 percent between March and June. Daily Discharge Hydrograph for Mill Creek near Walla Walla gaging station can be viewed at http://waterdata.usgs.gov/nwis/dv?referred_module=sw&site_no=14013000 .

Water is diverted upstream from Mill Creek at Walla Walla gaging station at: (1) the Mill Creek diversion structure, 200 feet upstream, into Yellowhawk Creek for irrigation and stock water rights, (2) the diversion dam (RM 11.4) into Bennington Lake (off-stream storage reservoir) for flood control, (3) other small upstream diversions, and (4) at the City of Walla Walla municipal water supply intake 11 miles above the station.

4-08. Water Quality. Water quality in the reservoir will be dependent on the quality of the water in Mill Creek when diversions of floodwaters occur. Water stored in the reservoir during a flood event will be evacuated as rapidly as possible after the event.

Mill Creek is a low alkaline, soft water stream. The land drained by the creek above the project generally consists of soils composed of loess and weathered basalt and loess and silty

clay loam, underlain by gravels. The headwaters region is developed with certain restrictions because of its use as a water supply source for the city of Walla Walla. Limited numbers of private recreational sites and cabins are located along the creek below the watershed area. As the creek reaches the lowlands, increases in summer cabins, population, and agricultural intensity are reflected in the quality of the creek water. Increases in temperature, pH, turbidity, and phosphorus have been recorded. Nitrate nitrogen in the upper reaches of the stream varies from 0.0 milligrams per liter (mg/l) to concentrations greater than 3 mg/l below the city of Walla Walla. Stream temperatures vary from near freezing in the winter to as high as 72°F in the summer. Daily temperatures have been observed to fluctuate as much as 21°F in the creek above Walla Walla. Due to the natural turbulence of the stream, dissolved oxygen concentrations maintain near 100 percent saturation along the majority of the stream.

4-09. Channel and Floodway Characteristics. The Waterways Experiment Station (WES) conducted model studies of Mill Creek. The WES model tests are based upon bed material scaled from actual samples of the Mill Creek channel. At flows above 1,700 cfs, the unlined channel bed upstream and downstream of the concrete lined channel becomes unstable. At some point above the design capacity of 3,500 cfs, the channel bed instability becomes severe enough to endanger levees through the loss of stabilizers and to undermine levee toe protection. The following summarizes design channel capacities:

a. Diversion Dam Forebay. Studies presented in DM No. 5 determined that the project forebay basin and the reconstructed diversion dam will contain the SPF of 11,300 cfs without allowing flow to bypass project control.

b. Mill Creek.

(1) Upstream Channel Section. Upstream of the concrete channel from Roosevelt Street (Sta 216+91) to the diversion dam spillway (Sta 370+12), the improved channel has a design capacity of 3,500 cfs.

(2) Concrete Channel Section. From Mullan Avenue (Sta 107+05) to Roosevelt Street (Sta 216+91), the concrete-lined channel has a design capacity of 5,400 cfs.

(3) Downstream Channel Section. Downstream of the concrete channel from Gose Street (Sta 5+60) to Mullan Avenue (Sta 107+05), the improved channel has a design capacity of 3,500 cfs.

c. Yellowhawk and Garrison Creeks. The two controlled auxiliary channels, Garrison and Yellowhawk Creeks, convey irrigation water to downstream water users. Lack of channel maintenance and residential developments along Garrison Creek has reduced the capacity of that stream for reliable passage of floodwater to about 10 cfs from the diversion works through the town of College Place. Similar channel restrictions exist on the upstream two-mile reach of Yellowhawk Creek. Flows in excess of 60 cfs begin to inundate residential lawns and landscaping improvements, and cause erosion.

4-10. Economic Data.

a. Population. The 2000 census lists the population of Walla Walla city as 29,700 and that of Walla Walla County as 57,000. It is estimated that the trade area of the city embraces a population in excess of 150,000.

b. Agriculture. Walla Walla County has 700,056 acres of tillable land, of which 96,067 acres are irrigated. The total amount of land devoted to wheat production for the county during 2002 was 200,247 acres. Other crops produced are dry peas, alfalfa, barley, oats, sugar beets, potatoes, onions, tomatoes, berries, apples, apricots, grapes and melons. The market value of agricultural products sold for 2002 was \$381,004,000.

c. Industry. The city of Walla Walla, protected by Mill Creek Reservoir, is a major trading center in southeastern Washington and northeastern Oregon. Total retail trade in Walla Walla county was \$570,735,778 in 2002.

d. Flood Damages. The following tabulation summarizes flood damages for the Mill Creek channel reach from the diversion dam downstream to the mouth of Mill Creek based on March 1986* price and development level with changes made to account for inflation**. The inflated rate only takes into account structures and improvements in place as of the 1986 study. Damages are likely to be much higher than indicated in the table due to increased development since 1986. A revised study is scheduled for the first quarter of FY '07.

Flow Versus Damage Relationship
Diversion Dam to Mouth of Mill Creek

November 2005 Dollar Value			
Flood Flow (cfs)	Improved Channel (Diversion Dam to Gose Street)	Natural Channel (Gose Street to Mill Creek Mouth)	Totals
500	\$0	\$0	\$0
1,000	0	0	0
2,000	0	63,567	63,567
3,000	0	118,053	118,053
3,500	0	208,863	208,863
4,000	181,620	363,240	544,860
5,400	817,290	1,180,530	1,997,820
6,000	2,270,250	1,761,714	4,031,964
8,000	11,442,060	3,132,945	14,575,005
10,000	28,151,100	4,131,855	32,282,955
11,500	38,140,200	4,758,444	42,898,644

*Source: Plan Formulation Branch, Corps of Engineers, Walla Walla District.

**Source: Walla Walla Regional Planning Department, 1999, Comprehensive flood management plan: Walla Walla County, Washington pg. 2-5 Source of inflation calculation : U.S. Department of Labor Bureau of Labor Statistics <http://www.bls.gov/cpi/home.htm>

The Mill Creek improved channel reach from the diversion dam downstream to Gose Street provides flood protection for the city of Walla Walla and adjacent downstream areas up to the design discharge of 3,500 cfs. From Gose Street downstream to the mouth of Mill Creek, flood damages begin with flows above 1,000 cfs and significant flood damages are incurred when flows exceed 2,000 cfs. Larger flood event overflows cause inundation and erosion of lands, erosion of the stream channel, and damages to crops and structures (roads, bridges, dwellings, etc.). Paragraph 4-06 provides details on past floods.

Flood problems of floodplain areas along Mill Creek above and below Walla Walla are described in "Flood Plain Information - Walla Walla River Tributaries," U.S. Army Corps of Engineers, Walla Walla Washington, June 1968.

Figure 4-1
Regional Temperatures
Mill Creek Project (1971-2000)

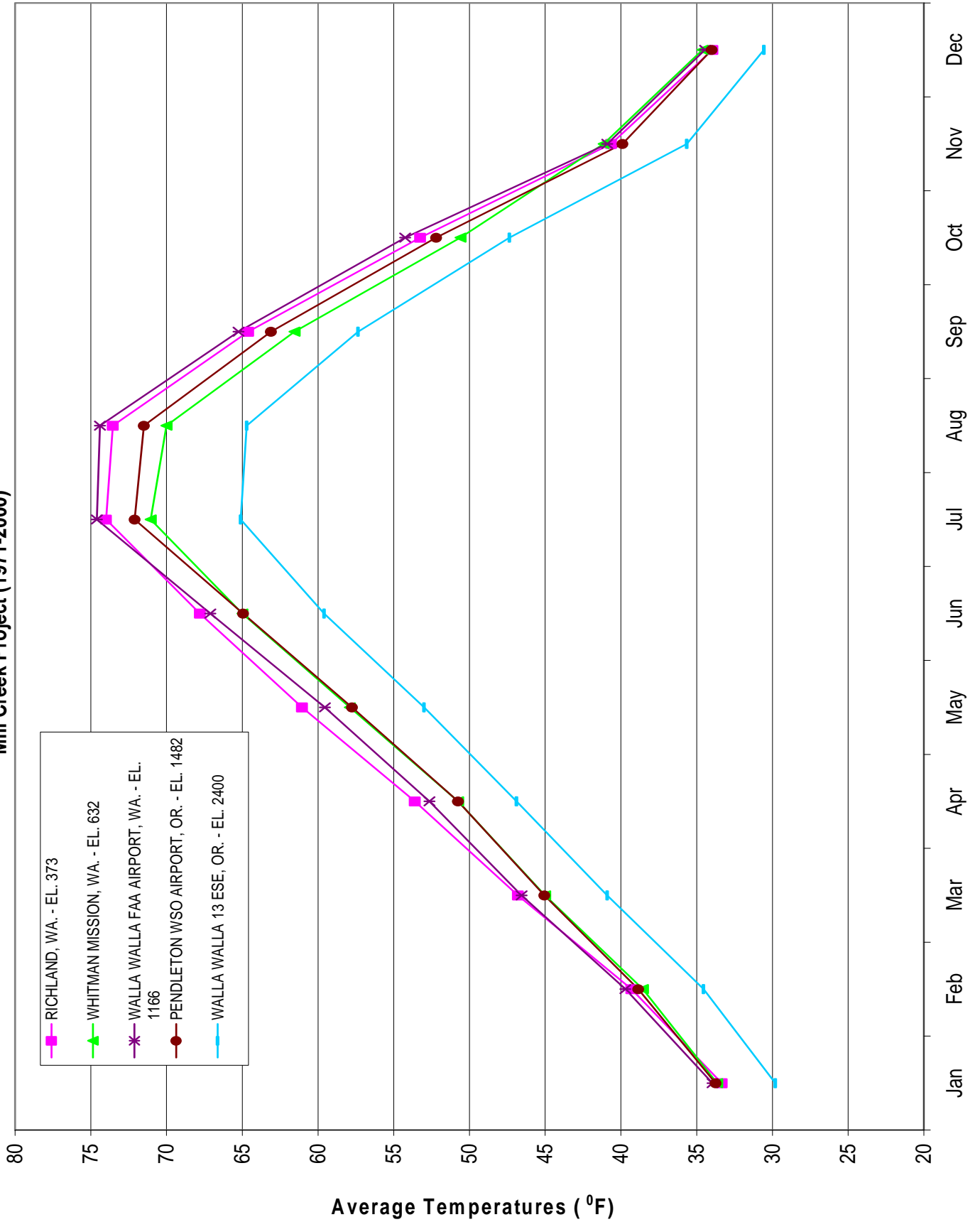

FIGURE 4 - 1

Figure 4-2
Regional Precipitation
Mill Creek Project (1971-2000)

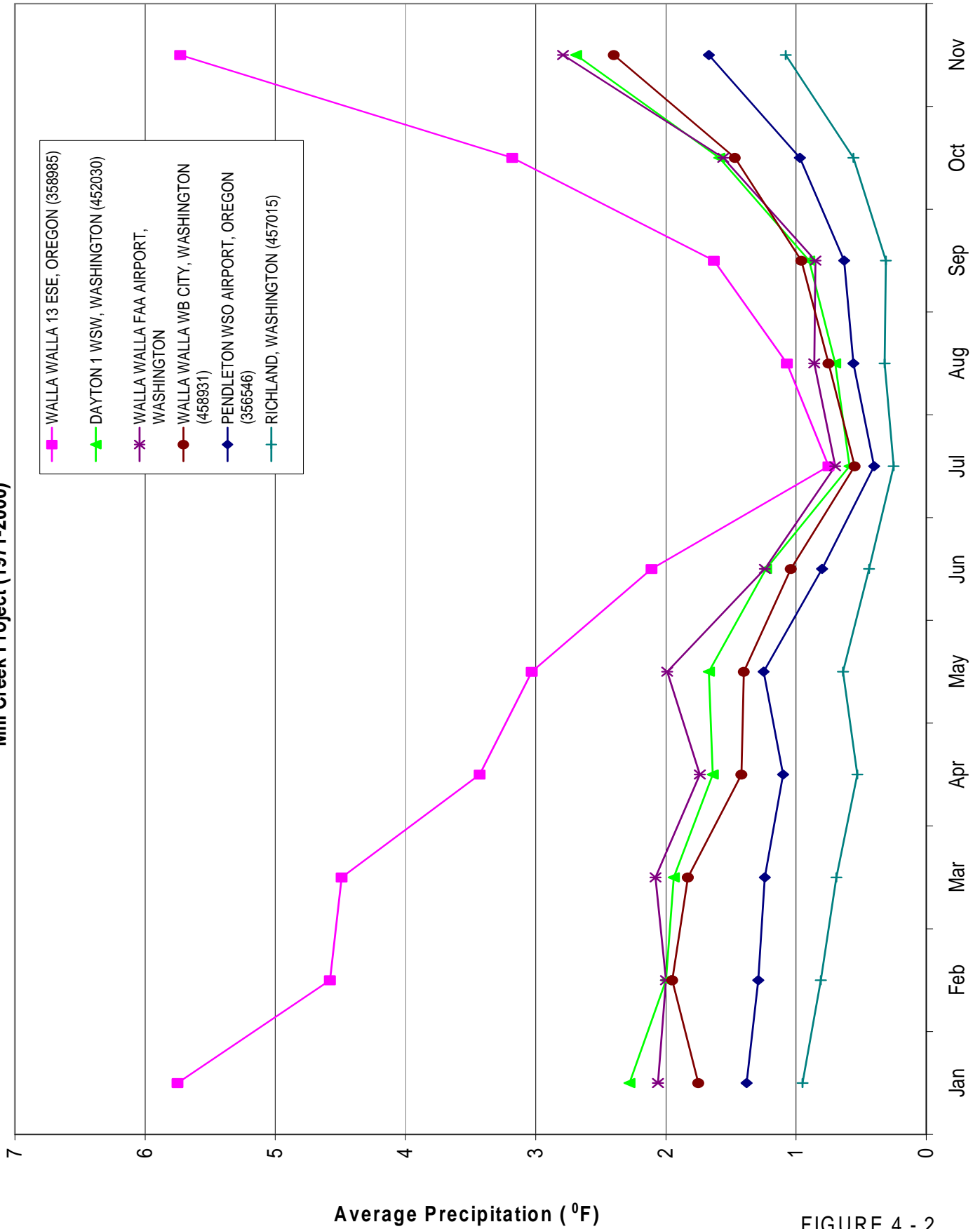
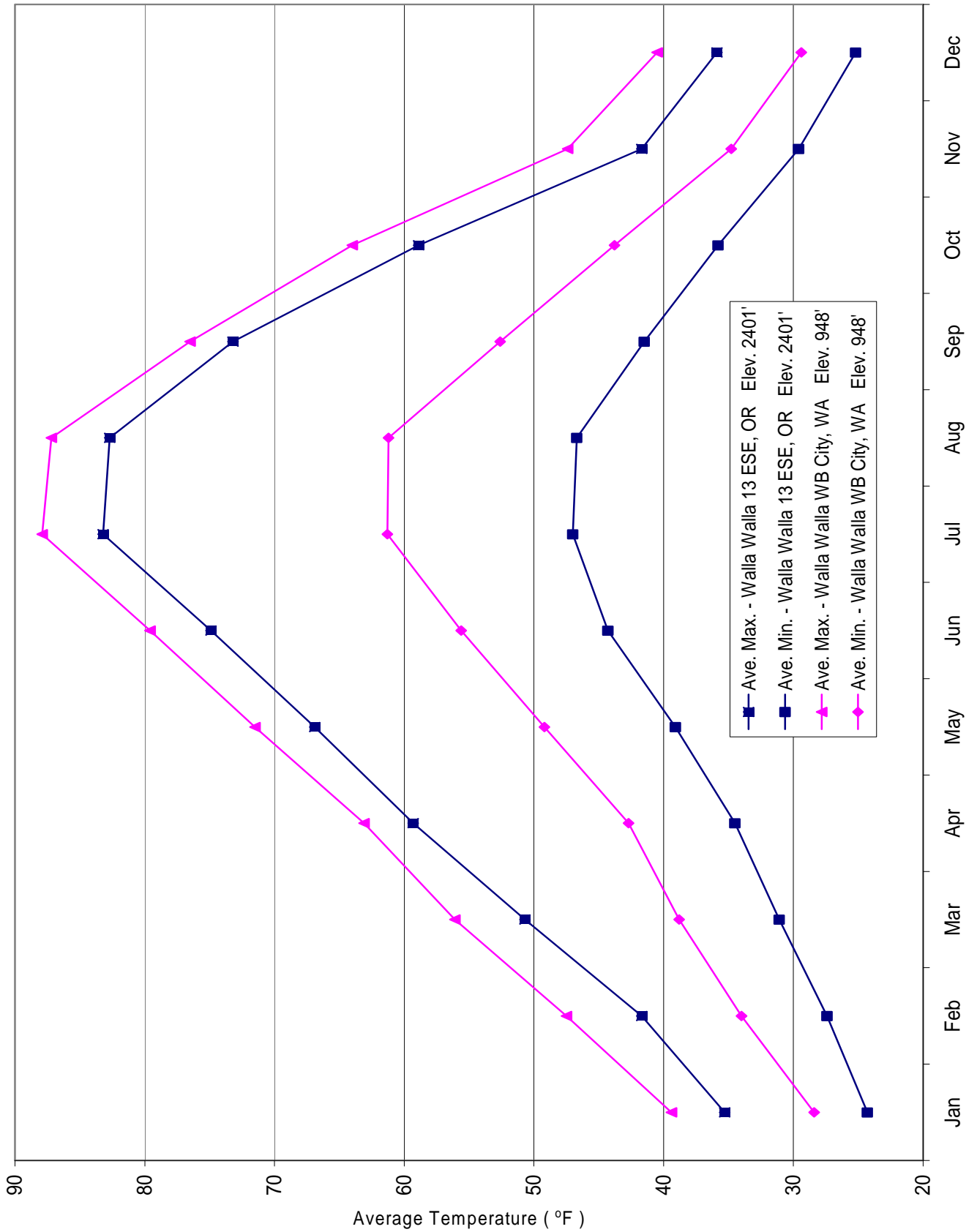

FIGURE 4 - 2

Figure 4-3
 Project Temperatures
 Mill Creek Project (1971-2000)



SECTION V - DATA COLLECTION AND COMMUNICATION NETWORKS

5-01. Data Collection.

a. General. Streamflow and project data are collected daily by project personnel on a year-round basis. The Hydrology Section monitors hydro-meteorological data (streamflow, precipitation, and weather) and project data daily during the flood control season, which generally extends from December through May.

b. Stream Gages. Plate 4-1 shows locations of two key stream gaging stations in Mill Creek Basin, (1) Mill Creek at Walla Walla, Washington gaging station (USGS Station No. 14015000) and (2) Mill Creek near Walla Walla, Washington gaging station (USGS Station No. 14013000). Streamflow records for these gaging stations are published by the U. S. Geological Survey in their publication, Water Resources Data for Washington and on the internet at www.usgs.gov.

In addition, these two stream gages are also telemetered and can be monitored from any commercial telephone on a real-time basis. Telephones are available at the diversion dam and project office for project personnel to monitor the two stream gages during a flood control operation.

c. Project Gages.

(1) Diversion Dam Forebay Gage. A forebay staff gage is located in the Diversion Dam's left abutment forebay area (Refer to Plate 2-3.4 for details). This gage can be used in conjunction with the adjustment of the four intake canal gates to estimate diversion flow into the reservoir (Refer to Plate 2-3.8, Intake Canal Headworks - Discharge Curves).

(2) Intake Canal Sloping Staff Gage. A sloping staff gage is located 325 feet downstream of the intake canal headworks and on the left bank of the intake canal. This gage can be used to check diversion flow into the reservoir for normal flow conditions and no backwater effect in the intake canal from the water stored in the reservoir during a flood.

(3) Reservoir Gage. A sloping staff gage is located adjacent to the boat ramp access road. This gage is a calibrated flat steel member that is anchored to a concrete foundation. During a flood event, the Flood Control Rule Curve shown on Chart 7-1, page 7-11, will be used to determine the required regulated flow below the diversion dam at Mill Creek at Walla Walla stream gaging station. As a result, it will be necessary to get the reservoir elevation at time intervals not exceeding one hour during a flood operation in order for the Hydrology Section to estimate the total natural flow above the Diversion Dam during a flood event. Consequently, it will be very critical to acquire reservoir elevation data as quickly and accurately as possible during a flood event.

5-02. Communication Facilities and Reports.

a. Communication Facilities. The communication systems available between the Mill Creek Project Office and the District include: (1) commercial telephone, (2) mobile radio, (3) and messengers because of close proximity to the project. Routine day-to-day operations of the project are coordinated by telephone. When potential high-water conditions exist that may require diversion of water to the reservoir, a mobile radio unit will be dispatched to the Mill Creek project for backup of telephone communication. Hydrologic information will be forwarded to the Hydrology Section and any information of unusual or unsatisfactory conditions of facilities and equipment that might have an effect upon flood control operations will be forwarded to the Operations Division and Hydrology Section.

b. Reports. The Project Manager is responsible for reporting project data and submitting a report to the Hydrology Section. This report will consist of a form showing (1) reservoir gage elevation and storage, (2) intake canal gage height and discharge, (3) Russell Creek outlet canal gage height and discharge, and (4) streamflows for Mill Creek at Walla Walla, Mill Creek near Walla Walla, 1st Division Works (Yellowhawk/Garrison), and 2nd Division Works (Yellowhawk and Garrison Creeks) gaging stations. This project report will be submitted to the Hydrology Section as soon as possible after the form is completed.

During the period November through June, the Hydrology Section will monitor streamflow and weather conditions in order to alert the Project Manager of flood potential conditions and/or provide regulation instructions for flood control operations. Additional reports on Mill Creek, Yellowhawk Creek, and Garrison Creek channel conditions may be requested during periods of high flood potential. It is planned that streamflow reports from the Project Manager or his representative will be required at least every four hours when the flow is between 1,000 cfs and 1,400 cfs, and every hour when the flow is over 1,400 cfs.

SECTION VI - HYDROLOGIC FORECAST

6-01. General. The diversion of streamflow into Bennington Lake, an off-stream reservoir, is an important element in the control of floods in Mill Creek downstream of the diversion dam and through the city of Walla Walla. Use of Chart 7-1, page 7-12, (Flood Control Rule Curve) to regulate Mill Creek floods requires a reasonably accurate value for the natural streamflow in Mill Creek at the project office (Mill Creek at Walla Walla stream gaging station). The total natural flow at Mill Creek at the Walla Walla stream gaging station will be computed by the Hydrology Section. A storage capacity curve and table for Mill Creek Reservoir are shown on Plate 2-4.2. Plate 4-1 shows locations of the two important stream gaging stations (Mill Creek near Walla Walla and Mill Creek at Walla Walla).

6-02. Flood Forecast. At the present time, there is no reliable short-term forecast procedure available that can be used on a real-time basis for predicting the stage and discharge for Mill Creek at the Walla Walla stream gaging station during a flood event. It would also be difficult to develop a reliable short-term forecast procedure (precipitation versus peak discharge) because real-time precipitation data for climate stations in the region is not available on demand. The following paragraphs summarize the responsibilities of staff level offices involved with flood forecasting during the flood control season (November - June).

a. Responsibilities of Staff Level Offices.

(1) Hydrology Section. Whenever the drainage area, streamflow conditions and current meteorological conditions indicate a high flood potential for the Mill Creek basin, the Hydrology Section will issue its customary alert to the Project Manager or representative (Damtender). During the progress of a flood, weather forecasts for the Mill Creek region will be obtained by the Hydrology Section from the National Weather Service (NWS) and passed on to the Damtender. The Damtender should be prepared for operation of diversion facilities (intake canal control gates, etc.) because of the short concentration time of floods on Mill Creek.

(2) National Weather Service (NWS). The NWS office in Pendleton, Oregon will notify the Walla Walla District Hydrology Section when alerts for "Flood Watch" and/or "Flood Warning" will be in effect for the Mill Creek region. The NWS will also provide weather forecasts for the Mill Creek basin upon request from the Hydrology Section. In addition, the NWS Northwest River Forecast Center (RFC) Portland, Oregon is authorized to issue coordinated runoff volume forecast, peak flow forecasts, and flood stage forecasts for key gaging stations within the Columbia River Basin.

b. Estimating Peak Discharges. Past records indicate that peak discharges of Mill Creek at the diversion dam range from 1.0 to 1.6 times those at Kooskooskie (listed in Water Supply Papers as Mill Creek near Walla Walla). On the average, peak flow at Kooskooskie multiplied by a factor of 1.25 will approximate the peak flow at Mill Creek

at the Walla Walla stream gaging station. A factor of 1.5 has been used to determine a conservative estimate of the peak flow at Mill Creek at the Walla Walla stream gaging station.

SECTION VII - WATER CONTROL PLAN

7-01. General Objectives. It is the objective of this Water Control Plan to define reservoir regulation procedures and practices for the use of storage space in Bennington Lake. The plan of regulation described in the following paragraphs considers the limitations of existing facilities with a view toward achieving the maximum overall protection.

7-02. Operating Constraints. Major operating constraints for the regulation of the Mill Creek Project include:

1. Reservoir Floodwater Evacuation.
2. Outlet Operation.
3. Russell Creek Outlet Channel Use.
4. Yellowhawk - Garrison Canal Gage Height Limitation.

a. Reservoir Floodwater Evacuation. After a flood event, floodwater stored in Bennington Lake above El. 1212 will be evacuated as soon as possible by using the Mill Creek return canal. Refer to paragraph 7-03 f., Evacuation of Bennington Lake, for details.

b. Outlet Operation. The 42-inch discharge conduit through the embankment was designed not to be under pressure for any extended length of time. As a result, the following procedure will be followed for operation of the Bennington Lake outlet:

(1) Opening Outlet.

- Close the 36-inch Howell-Bunger valve and the 36-inch diameter gate valve in the lower valve house (Inlet to Russell Creek Outlet Canal) to prevent any flow from entering Russell Creek.
- Open the 42-inch butterfly valve in the pipeline to upper valve house (inlet to Mill Creek return channel) to allow air to escape during the filling of the pipeline and minimize the blow back problem.
- Open the 54-inch sluice gate in the in-take tower slightly (approximately 1/2-inch). Allow the pipeline to fill to the upper valve house (inlet to Mill Creek return channel). This will also minimize the blow back problem.
- Continue opening the 54-inch sluice gate until the gate is 100% open. The 54-inch diameter sluice gate in the intake tower will not be used for regulating the discharges from Bennington Lake.

(2) Closing Outlet.

- Close the 42-inch diameter butterfly valve.
- Close the 54-inch sluice gate completely.
- After the sluice gate is completely closed, open the 42-inch butterfly valve and then open the 36-inch Howell-Bunger and gate valves in the lower valve house slightly to prevent pressure build up in the conduit.

c. Russell Creek Outlet Channel Use. The Russell Creek outlet channel will not be used to evacuate stored floodwater from Bennington Lake under normal operating conditions. Use of the Russell Creek Outlet channel can only be authorized by the Chief of Hydrology Section or representative when evacuation of water stored in Bennington Lake between elevation 1187 and 1212 is required under emergency conditions. In the past, releases from Bennington Lake into Russell Creek have resulted in downstream property owner complaints of bank erosion.

d. Yellowhawk - Garrison Canal Gage Height Limitation. At present, downstream encroachments onto the floodway of Yellowhawk and Garrison Creeks, limits the maximum staff gage height in the canal to 0.9 feet during a flood event. This staff gage is located on the right abutment wall for the radial lift gate. The Yellowhawk-Garrison Canal leads to the 2nd division works where it is further divided between Yellowhawk Creek (60 cfs maximum) and Garrison Creek (10 cfs maximum).

7-03. Flood Control Plan.

a. General. The city of Walla Walla and the area below Walla Walla are protected from flooding by diversion of floodwaters into Bennington Lake (an off-stream storage reservoir) and a reach of improved Mill Creek channel. The improved Mill Creek channel consists of three sections: (1) an upstream riprapped levee section, (2) a concrete lined channel section, and (3) a downstream riprapped levee section. The designed hydraulic capacity of the concrete lined channel section through the city of Walla Walla is 5,400 cfs. The original designed hydraulic capacities of the riprapped levee sections upstream and downstream of the concrete channel were also 5,400 cfs. However, results from hydraulic model studies indicated that the leveed reaches of the improved channel were not stable for discharges above 3,500 cfs. Below the improved Mill Creek channel reach, the natural channel from the Gose Street Bridge to the mouth of Mill Creek has a capacity of approximately 1,400 cfs. At flows of 1,400 cfs, minor overbank flooding, and some channel erosion occurs in the natural channel reach. Flow in excess of 1,700 cfs floods homes and seriously erodes channel banks, roadways, and bridge abutments. Regulation procedures and practices currently used to control Mill Creek flows during a flood event and minimize annual flood damages are outlined in the following paragraphs:

b. Flood Period. A flood period will be defined as a period when natural Mill Creek flows exceed 1,400 cfs at the project office stream gage (USGS gage No. 14015000, Mill Creek at Walla Walla, Washington). Table 7-1 shows a discharge rating table for this gaging station.

c. Flood Diversions. Diversions to Bennington Lake for flood control begin when the Mill Creek flow exceeds 1,400 cfs at the project office gage (USGS gage No. 14015000, Mill Creek at Walla Walla, Washington). Flows above 1,400 cfs are then diverted to Bennington Lake until the flood event is over or until lake elevation limits on the flood control rule curves shown on Chart 7-1, page 7-12, are reached. An initial regulation objective of 1,400 cfs passing the project office gage is used to limit flows in the lower natural channel reach (below Gose Street) to approximately natural channel capacity and provide flood control protection for the more frequently expected floods.

d. Change of Regulation Objective. During major flood events, the regulation objective is increased above 1,400 cfs to a maximum of 3,500 cfs as the pool fills according to the flood control rule curves shown on Chart 7-1, page 7-12. This sliding regulation objective is a function of both the natural Mill Creek flow at the main diversion dam and Bennington Lake elevation. Increasing the regulation objective above 1,400 cfs for major flood events is necessary to prevent losing control of the flood through Walla Walla because of prematurely filling Bennington Lake to protect the natural channel reach below Walla Walla and also to effectively utilize Mill Creek flood control space for various magnitude flood events. Increasing the regulation objective above 1,400 cfs and up to a maximum of 3,500 cfs can only be authorized by the Chief of the Hydrology Section or representative.

e. Flood Control Operation. The Hydrology Section's Reservoir Regulation Section will be responsible for providing instructions and regulation schedules on flood control operations to the Damtender (Project Manager or his representative) for the Mill Creek Project during the progress of a flood event. The Hydrology Section will also be responsible for monitoring weather conditions (call or receive weather forecasts from the NWS) and streamflow conditions (discharge and channel conditions). Gage height data is available on a real-time basis with discharge rating tables for Mill Creek at Walla Walla (USGS 14015000) and Mill Creek near Walla Walla (USGS 14013000) stream gaging stations are shown in Table 7-1 and Table 7-2. The plan of operation during a flood event will be coordinated with the Mill Creek Damtender. Figure 7-1, page 7-10, outlines staff level functions and data sources (stream gages, NWS reports). Pertinent features of the flood control plan include:

(1) When flows in Mill Creek are less than or equal to 400 cfs, the diversion dam's 6-foot-wide-by 8-foot-high radial sluice gate (north gate) will be adjusted as needed to maintain the water surface elevation in the diversion dam's forebay area between elevation 1253 and 1256 with the four intake canal headworks gates fully closed in order to provide adequate flows for operation of the fish ladder.

(2) When the "Flood Alarm Pager" for Mill Creek at Walla Walla (USGS

14015000) stream gaging station alerts the Damtender that flow is greater than 400 cfs or the flow is forecasted to remain over 400 cfs for more than 24 hours, the diversion dam works shall be operated with (1) the 6-foot-wide-by 8-foot-high sluice gate closed and (2) the fish ladder entrance gate cracked open 6-inches. After the adjustment of these two gates, the majority of flow past the diversion dam will be over the spillway of the diversion dam with the forebay ponding to the spillway discharge elevation. This operation will prevent debris from plugging the entrances of the north gate and fish ladder while providing water for fish until the forebay elevation rises above the spillway. Once the flow crosses the spillway the fish ladder gate should be closed the rest of the way. Next, open the two center gates at the first division. This will reduce the chance of any debris damaging these gates.

(3) When the "Flood Alarm Pager" for Mill Creek at Walla Walla stream gaging station (USGS 14015000) alerts the Damtender that flow is in the range of 1,000 cfs to 1,400 cfs and on a rising hydrograph the Damtender shall take preparatory actions for opening the intake canal gates to the reservoir. As well as, opening all four gates at the first division works.

(4) There shall be no diversions of floodwater into Bennington Lake until the flow in Mill Creek at Walla Walla stream gage reaches 1,400 cfs.

(5) Whenever the natural flow in Mill Creek at Walla Walla stream gage is 1,400 cfs or greater, the diversion dam's intake canal gates shall be adjusted as necessary to regulate the flow passing the Mill Creek at Walla Walla stream gage according to the flood control rule curves shown on Chart 7-1, page 7-12. Reference to Chart 7-1 to determine the desired regulated discharges should be made at intervals not exceeding one hour for flood regulation. Natural flows will be determined as the sum of discharges passing Mill Creek at Walla Walla stream gage and through the intake gates (Bennington Lake inflow). The Hydrology Section will be responsible for computing Bennington Lake inflow.

(6) During a flood period the intake control gate at the first division works for the Yellowhawk-Garrison Canal will be set so that the maximum staff gage height of 0.9 feet in the canal is not exceeded when the flows in Mill Creek at Walla Walla stream gage, near the project, office exceed 1,400 cfs, up to a maximum of 3,500 cfs (See Figure 7-2, page 7-11).

(7) Under no circumstances should the regulated discharge passing the project office be allowed to exceed 3,500 cfs while space remains in the reservoir or diversion capacity remains at the diversion dam.

(8) After the reservoir is completely filled to El. 1,263 ft msl, the intake gates should be closed to limit the pool elevation to less than or equal to 1265, which will minimize freeboard encroachment.

(9) As flood flows decrease on a falling hydrograph, the intake gates

should be adjusted as necessary to maintain the flow past the project office stream gage at the maximum discharge reached during the control period without exceeding the maximum upper limit of 3,500 cfs.

(10) There is evidence that high hydrostatic pressures can develop at the toe of the storage dam during prolonged periods of high reservoir levels; therefore, the reservoir must be evacuated as quickly as possible. The reservoir should not be maintained above El. 1,235 for more than 15 days. This rapid evacuation to El. 1,235 must be accomplished even at the expense of nominal downstream flood damage. Floodwater stored in the reservoir will be released through the Mill Creek return channel.

(11) A record or diary of all decisions made and actions taken before, after, and during a flood period shall be kept by personnel staff level involved in the flood operation.

(12) During an extreme flood event, a considerable debris load is anticipated. The debris barrier is designed to catch the majority of this debris; however, the debris barrier has not been tested under extreme flood conditions. Therefore, it is important that the performance of the barrier be monitored closely during a major flood event. If a significant amount of debris is bypassing the barrier, then the following areas need to be checked frequently during the flood event: (1) the diversion dam forebay area and (2) downstream structures (i.e., 1st Division Works, covered channel reaches, and bridges). If debris becomes a problem at these locations, the Operations Division will be responsible for implementing and accomplishing corrective actions.

f. Evacuation of Bennington Lake. For normal operating conditions, evacuation of Bennington Lake is required to minimize seepage damage caused by sustained storage of floodwater, and to make space available for future flood events. Floodwater stored in the reservoir above El. 1212 should be evacuated as soon as streamflow conditions permit by the return canal to Mill Creek. Chart 7-2, page 7-13, shows drawn down times to El. 1212 with the return canal valve fully (100 percent) open.

Use of the Russell Creek outlet channel can only be authorized by the Chief of Hydrology Section or representative for emergency conditions only. Chart 7-3, page 7-14, shows drawdown times from elevation 1212 to 1187 for 20 cfs, 50 cfs, and 100 cfs releases into the Russell Creek outlet canal.

Water will be released from the lake at a rate not to exceed the set regulation objective of 65 cfs at the Depping Road Bridge, gage height 6.4 feet \pm 0.2, and South 3rd Street Bridge, gage height 5.4 feet \pm 0.2, staff gaging stations on Russell Creek. As the natural flows of Russell Creek increase or decrease, releases from the lake to the Russell Creek channel will be adjusted by equal amounts. This evacuation plan will be followed until the lake elevation has been reduced to 1187.0.

7-04. Conservation Plan. Bennington Lake is normally filled to a conservation pool elevation of 1205.0 near the end of the winter flood control season (March or April) using

surplus Mill Creek water. The 1205.0 pool elevation is maintained by small diversions to the lake until Mill Creek irrigation demands (normally after 1 May) leave little or no water available for diversion to the lake. By the end of the summer, evaporation and seepage normally reduce the lake elevation to approximately 1185-1190.

7-05. Irrigation Plan. Since 1942, encroachments on the floodplain of Yellowhawk and Garrison Creeks, outside of the project boundaries, have reduced the reliable hydraulic capacity of these two streams to about 60 cfs and 10 cfs for Yellowhawk and Garrison Creeks, respectively. Currently these two creeks are not effective for flood control and are only used for transferring irrigation water to meet downstream water rights (See Figure 7-2). As a good neighbor, the Corps has continued to operate the 1st and 2nd division even after the dual functions of flood control and irrigation for Yellowhawk and Garrison Creeks had changed to irrigation only. Irrigation water requirements for the Gardena Farms Irrigation District are provided through requests from the Watermaster to the Mill Creek Project Manager.

7-06. Standing Instructions. The following is a list of standing instructions that assure reservoir regulation functions can be performed by project personnel during flood control operations:

a. Normal Conditions:

(1) Debris Removal. The design concept of how the debris barrier would function is as follows:

- During a flood the barrier would hold debris upstream of the diversion dam;
- After a flood, the trapped debris would be removed.

This plan would prevent excessive debris accumulation which could cause extreme flows to bypass the diversion dam.

(2) Diversion Dam forebay Area Maintenance. The successful operation of the diversion control system (diversion dam and intake canal headworks) and debris control measures (upstream debris barrier and debris shear wall) depends on continuing maintenance of the forebay area (excavated pond area and cleared floodway) upstream of the diversion dam. This maintenance work must be accomplished on an as-needed basis in order to assure that extreme flows, including the SPF (11,300 cfs), will not bypass the diversion dam (main control point). If flood flows bypass the diversion dam, out-of-bank flows would likely flood areas north of the improved channel, including Walla Walla Community College. The design configuration of the basin must be maintained for the following reasons:

1. To maintain the streamflow pattern in the forebay area above the diversion dam so that debris will be directed into the debris barrier rather than around it.
2. To maintain the structural stability of the diversion dam. Excessive sediment buildup against the upstream face of the diversion dam would result in failure by sliding or overturning of the structure.
3. To maintain operational capability of four intake canal control gates. Excessive debris and/or sediment buildup against these gates would hamper the operation of these intake canal control gates. The operation of these gates is a critical element for diverting floodwaters.
4. To maintain design freeboard at diversion dam dike. Debris jams against the debris barrier and sediment buildup in the forebay area will increase the water surface profile above the diversion dam. This would encroach upon the design freeboard of the diversion dam dike, which may cause floodwaters to bypass the diversion dam.

The Project Manager has the primary responsibility for monitoring debris conditions at the barrier and the diversion dam forebay area. The Project Manager would report debris and/or sediment problems to the Operations Division. Also, periodic inspections, which are conducted every 3 years, would provide additional monitoring of debris and sediment conditions above the diversion dam and if problems exist the Operations Division will be notified by the inspection team. The Operations Division will be responsible for taking corrective actions.

(3) Operation and Maintenance Equipment. The following gates and valves shall be operated once every six months to confirm their operability and assure proper maintenance:

1. 4 radial gates (8 ft x 18 ft) in Intake Canal Head works.
2. 1 radial gate (6 ft x 8 ft) in Diversion Structure.
3. 48-inch sluice gate in Intake Tower - raise and lower 12-inch minimum.
4. 54-inch diameter sluice gate in Intake Tower - fully open and close. Outlet conduit should be filled prior to this inspection to minimize pressure differential. This may be accomplished by closing 36-inch gate valve and 42-inch butterfly valve some time prior to this inspection and allowing conduit to fill slowly from sluice gate leakage or by partially opening sluice gate.

5. 42-inch butterfly valve in pipe to Upper Valve House - fully open and close with the outlet conduit depressurized.
6. 36-inch Howell-Bunger Valve in Lower Valve House - fully open and close with the outlet conduit depressurized.
7. 36-inch gate valve in Lower Valve House - fully open and close with the outlet conduit depressurized. If there is evidence of sediment accumulation in the valve seat recess preventing complete closure, the gate disc should be moved up and down at the nearly closed position with water flowing through it to flush material from the recess.
8. The radial gates at the Intake Canal Headworks and the Diversion Structure have worm gear lubricant which should be drained in April or May each year to separate any accumulated water. The lubricant may be returned to the gear case if tests ensure that it is in good condition.
9. If any of these gates or valves receive normal functional use during an inspection period, that operation may be considered an inspection and need not be repeated during that inspection period.

b. Emergency Conditions. Emergency conditions are unforeseen and cannot be provided for in this Water Control Manual. Should an emergency occur or appear to be developing, the Project Manager or his representative should contact his immediate supervisor. If the nature of the emergency requires immediate action to prevent loss of life and property, the Project Manager will take the necessary action and report all circumstances to the Chief of the Operations Division as soon as possible. For further guidance see the Emergency Action Plan for Mill Creek Project.

NOTE: Refer to pages iii and iv (pink sheets in the front of this manual) for telephone numbers and guidelines on emergency conditions.

c. Communication Outage. In the event normal telephone communication outage, communication between the project and the District will be established through the NPW radio system and/or messengers because of close proximity to the project.

7-07. Water Quality. Water quality in the reservoir is dependent on the quality of the water in Mill Creek when a diversion of floodwater occurs. Water stored in the reservoir during a flood event will be evacuated as rapidly as possible after the event.

7-08. Fish and Wildlife. Fish and Wildlife issues are considered as much as possible during non-flooding operations.

7-09. Water Control Plan. The preceding sections have described several cases where a deviation may need to be considered in the regulation of the project. Deviation requests usually fall into one of the three categories: (1) emergencies, (2) unplanned minor deviations, and (3) planned deviations. Each is discussed in the following paragraphs.

a. Emergencies. Some emergencies that can be expected are drowning and other accidents, and failure of operation facilities. Necessary actions under emergency conditions are taken immediately unless such action would create equal or worse conditions. Actions under emergency conditions shall utilize the following priorities:

- (1) Protection of human life.
- (2) Protection of personal property.
- (3) Execution of the water control plan.

Normally, use of the water control plan will serve to protect human life and property. However, isolated incidents have occurred whereby the Project Manager has been required to deviate from the plan without prior notification to the regulating office. In the interest of providing rapid response to the protection of life and property, the Project Manager for Mill Creek shall follow priorities (1), (2), and (3) above, and make immediate contact with Walla Walla District's Chief of Operations and the Chief of Hydrology Section. A written conformation from Operations showing the deviation and conditions will be furnished to RCC (CENWD-ET-WR) after the emergency has been resolved.

b. Unplanned Minor Deviations. There are unplanned instances that create a temporary need for minor deviations from normal regulation. Construction accounts for a major portion of the incidents. Changes in releases are sometimes necessary for maintenance and inspection. Requests for changes of release rates range generally from a few hours to a few days. Each request is analyzed on its own merit. A written confirmation showing the deviation and conditions will be furnished to RCC (CENWD-ET-WR). In addition, unplanned minor deviations should be coordinated by Walla Walla District's Chief of Operations and the Chief of Hydrology Section.

c. Planned Deviations. Planned deviations from the water control plan include actions for which some benefit may be gained if undertaken, and for which time is available to provide an analysis of the trade-offs involved to form the basis for a decision. The analysis and decision-making needed should involve a multi-disciplinary approach that includes structural, hydraulic, environmental, and operations personnel as required. The decisions will be approached on a collaborative basis with both the District and Division offices involved.

Figure 7-1
Mill Creek Project
Flood Control Plan-Operational Flow Chart

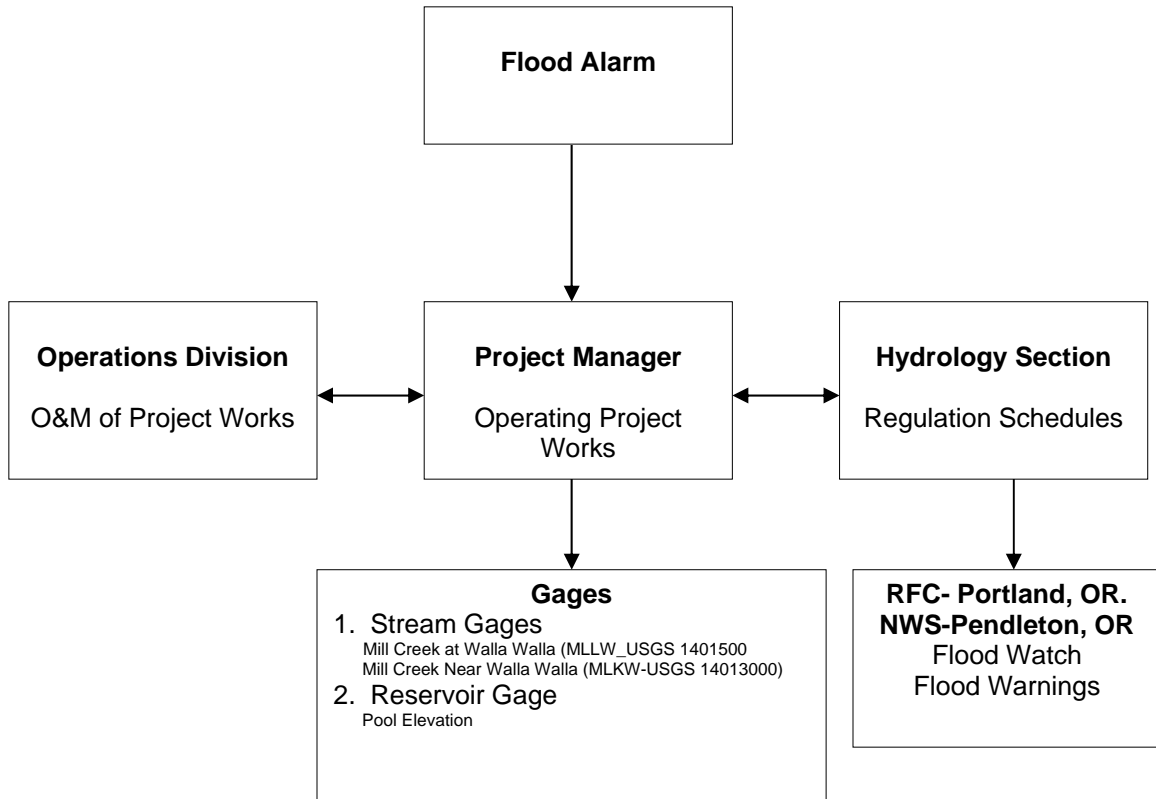

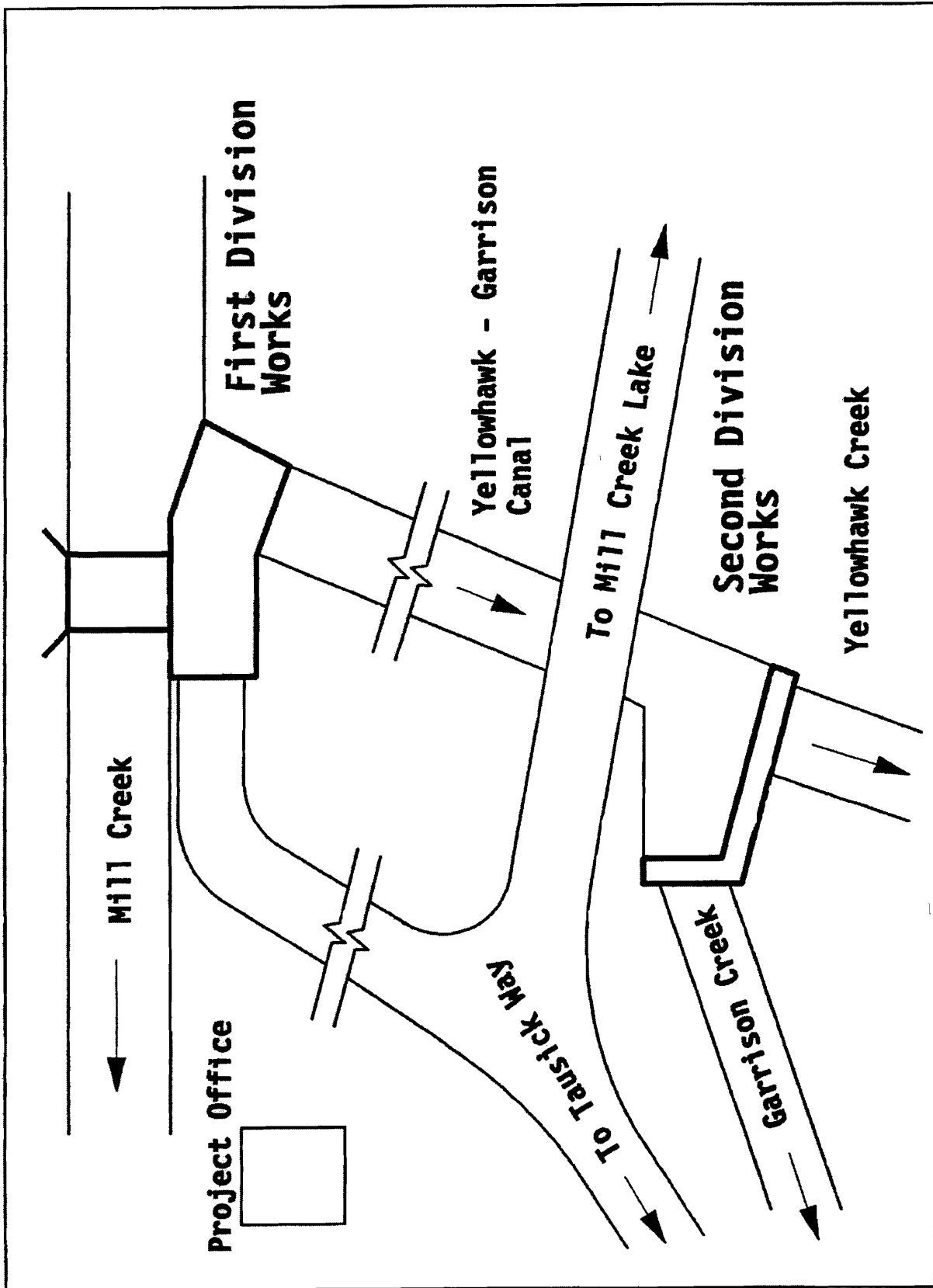

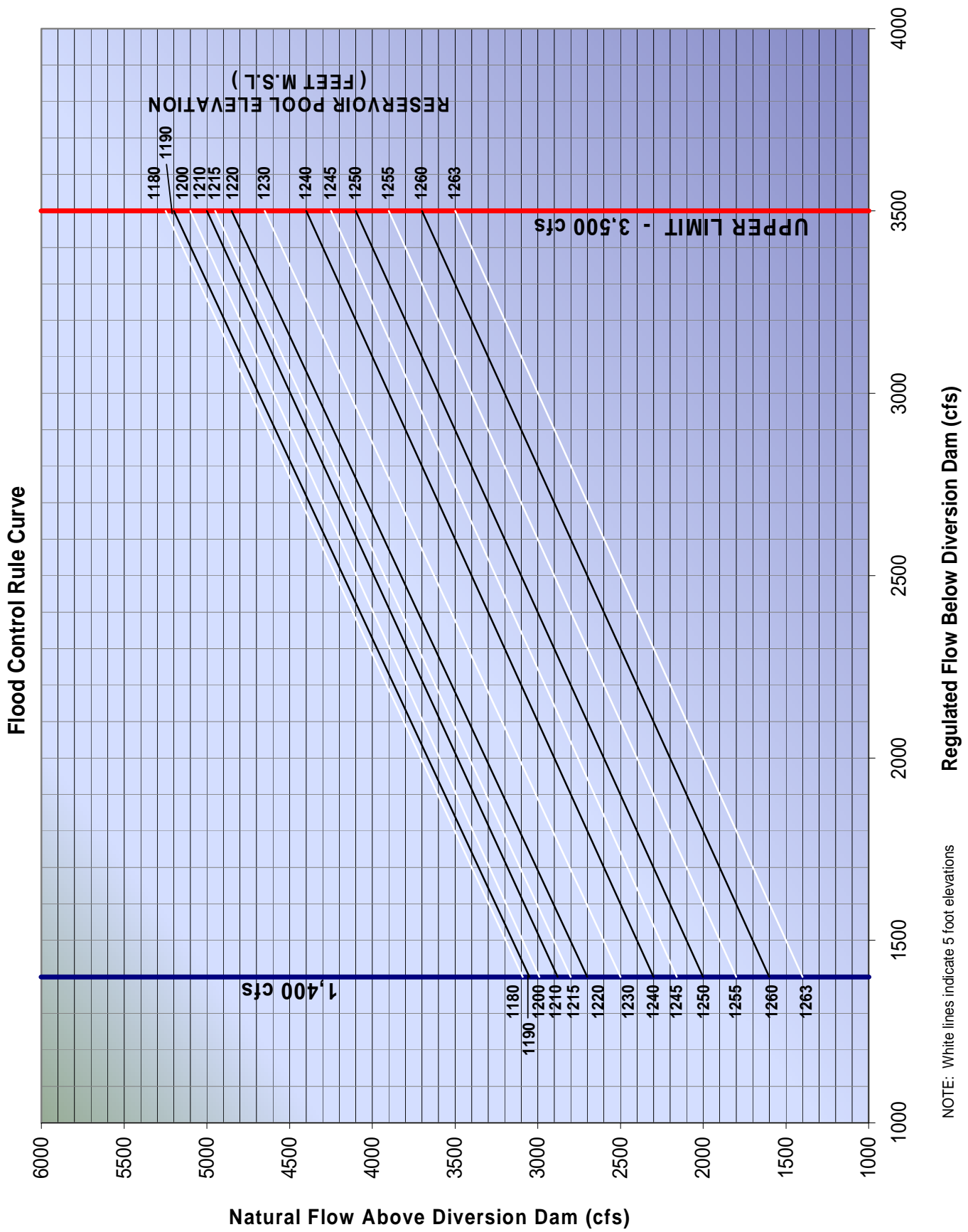

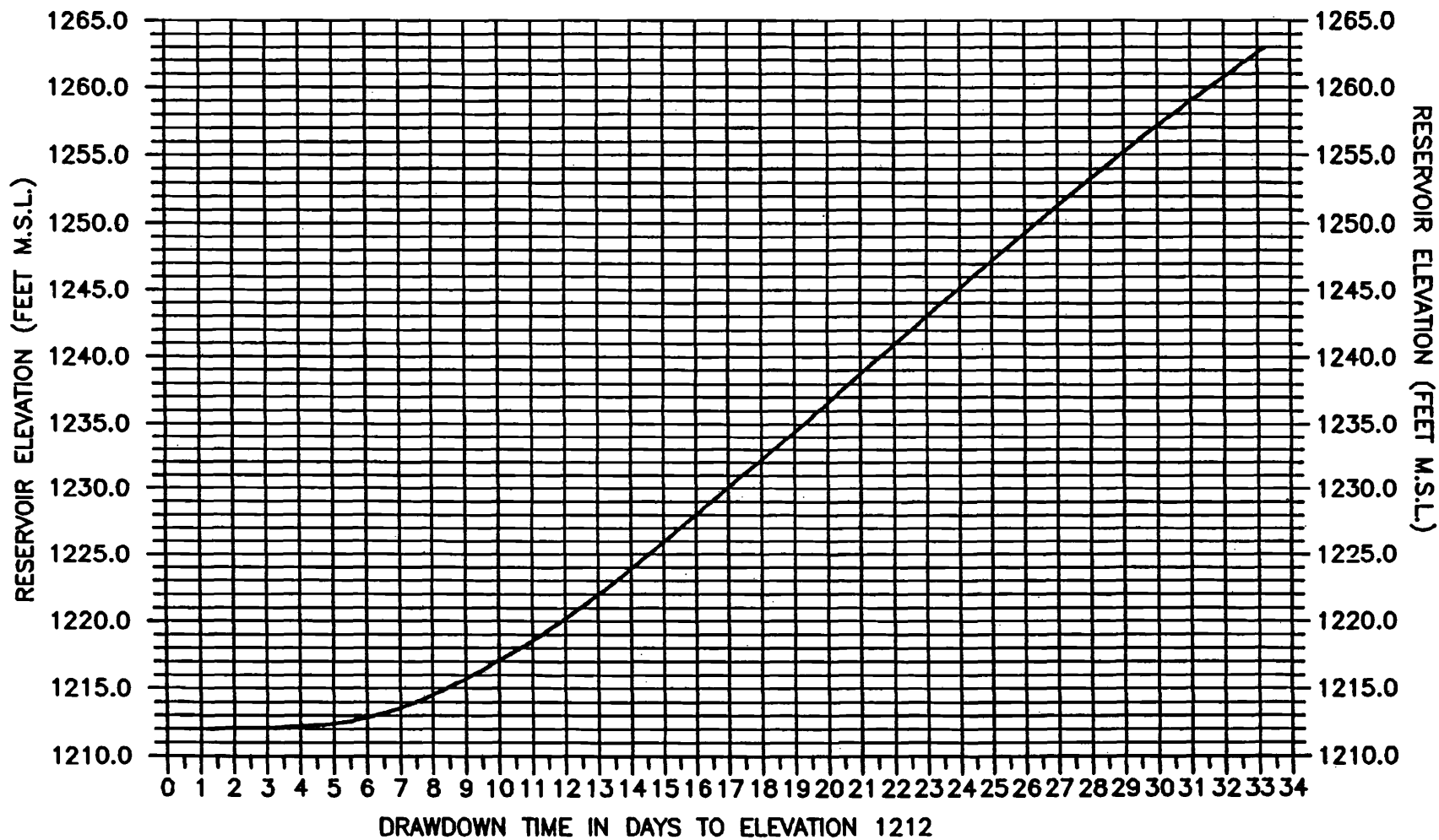

NOTES:

1. Derived from Discharge Curves by Hydraulic Design, dated 29 November 1979.
2. Mill Creek return outlet canal valve fully open.
3. Evaporation and seepage not taken into account.

MILL CREEK LAKE
Walla Walla, Washington

DRAWDOWN CURVE
(ELEVATION 1263 TO 1212)

U.S. ARMY CORPS OF ENGINEERS
WALLA WALLA DISTRICT - HYDROLOGY BRANCH

Prepared: G. Hardin
Checked By: E. Kim

Revised
January 1989

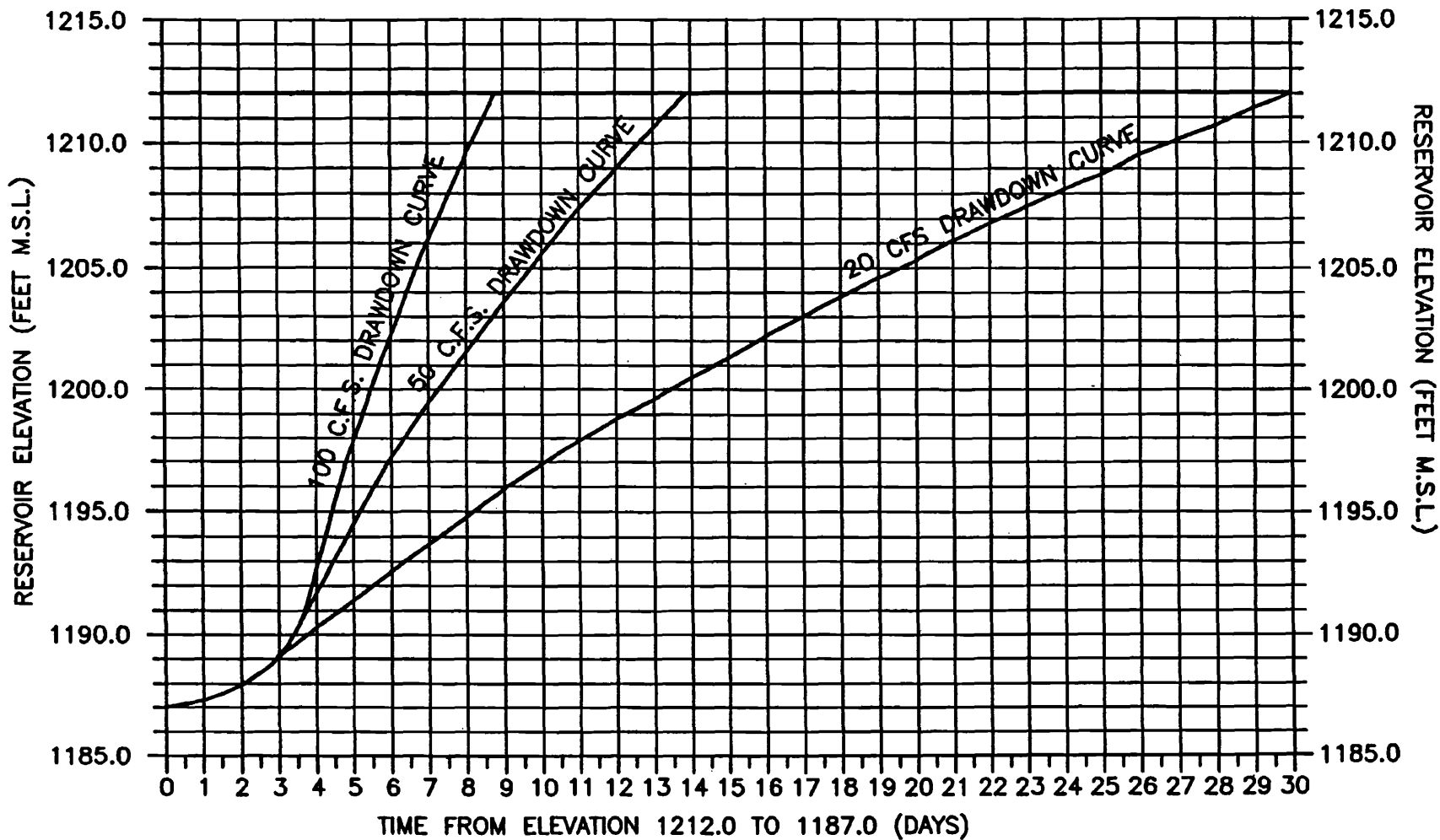

NOTES:

1. Derived from Discharge Curves by Hydraulic Design, dated 29 November 1979.
2. No discharge to Mill Creek return outlet canal.
3. Evaporation and seepage not taken into account.

MILL CREEK LAKE
 Walla Walla, Washington
DRAWDOWN CURVE
 (ELEVATION 1212 TO 1187)
 U.S. ARMY CORPS OF ENGINEERS
 WALLA WALLA DISTRICT - HYDROLOGY BRANCH
 Prepared: G. Hardin
 Checked By: E. Kim
 Revised
 January 1989

SECTION VIII - EFFECT OF WATER CONTROL PLAN

8-01. General. The project is operated according to reservoir regulation criteria presented in this Water Control Manual for flood control and conservation functions. The effects and benefits of the Water Control Plan are discussed in the following paragraphs.

8-02. Specific Frequency Lake Elevations. Specific frequency lake elevations were determined by regulation of specific frequency floods and using the flood control rule curves shown on Chart 7-1, page 7-11, with a regulation objective upper limit of 3,500 cfs for flood control only. Results are summarized in the following tabulation:

Specific Frequency Lake Elevations

<u>Recurrence Interval (Years)</u>	<u>Probability ^{1/} (percent)</u>	<u>Flood Control Operation Lake Elevation ^{2/} (feet msl)</u>
5	20	1199.5
10	10	1217.9
20	5	1231.0
50	2	1239.5
100	1	1243.5

^{1/} Probability of filling reservoir to the indicated elevation or higher in any given year.

^{2/} Used a starting pool elevation of 1190

There is a 20 percent probability (5 year average recurrence interval) that a more frequent flood would fill the reservoir to El. 1199.5 or higher in any given year and a 1 percent probability (100 year average recurrence interval) that a less frequent or extreme flood would fill the reservoir to El. 1243.5 or higher in any given year.

8-03. Flood Frequencies. Using the flood control rule curves shown on Chart 7-1, page 7-11, with a regulation objective upper limit of 3,500 cfs provides control of natural flows in Mill Creek up to a 140-year flood through the city of Walla Walla. Regulated flood frequencies for a 3,500 cfs flood control regulation objective for Mill Creek at Walla Walla are shown on Plate 7-1 and are summarized in the following tabulation:

MAXIMUM ANNUAL PEAK DISCHARGE FREQUENCIES

Exceedence Probability (percent)	Average Recurrence Interval (years)	Unregulated Discharge (cfs)	Regulated Discharge (cfs)
50	2	1,180	1,180
20	5	2,000	1,470 *
10	10	2,400	1,470 *
5	20	3,800	2,500
2	50	5,400	3,500
1	100	7,050	3,500
Standard Project Flood		11,300	10,000

* 1,400 cfs in Mill Creek and 70 cfs in Yellowhawk - Garrison Canal

SECTION IX - WATER CONTROL MANAGEMENT

9-01. General. The Corps of Engineers as owner and operator of the Mill Creek Project is directly responsible for the day-to-day project regulation and operation. The administration of the plan of regulation documented in SECTION VII - WATER CONTROL PLAN of this manual will at all times be oriented for the primary purpose of flood control and consideration for other interests, such as recreation, irrigation, and conservation. Functional water regulation is the responsibility of the Walla Walla District, Engineering Division, with responsibility for details assigned to the Hydrology Section. Physical operation and maintenance of the project are the responsibility of the Operations Division. Project responsibility is assigned to the Project Manager. Pertinent organization structures, and personnel and telephone numbers of Mill Creek Project are shown on pages 9-4 and 9-5, respectively. The following paragraphs cover: (1) responsibilities and organization structures of the Corps of Engineers and other entities involved both directly and indirectly with the water control management of the project, (2) communication procedures, and (3) public information.

9-02. Corps Of Engineers

a. Planning Division. The responsibilities of the Engineering Division's Hydrology Section with regard to regulation of Mill Creek Reservoir for flood control include the following:

- (1) determination of regulating schedules and plans;
- (2) analysis of hydrologic data for preparation of flood forecasts;
- (3) dissemination of flood forecasts;
- (4) assistance in coordination of flood control activities; and
- (5) preparation of manuals and reports on flood regulation.

b. Operations Division. The Operations Division is responsible for:

- (1) operation of the project to achieve flood-control objectives;
- (2) coordination of flood control operations;
- (3) maintenance of the physical features of the project;
- (4) direction of emergency operations;
- (5) liaison with the Mill Creek Flood Control District; and
- (6) provision of radio communication.

c. Responsibilities of Project Manager. The Project Manager is the Corps of Engineers representative at the project. With him lies the final responsibility for implementing the plan of regulation. Other duties include normal inspection and maintenance of dams, channels, buildings, equipment, grounds, and recreation facilities. Detailed water regulation responsibilities include:

- (1) performance of necessary operations for proper diversion of flood flow and for storage and release of water;
- (2) maintaining a continuing vigilance of streamflows;
- (3) collecting and reporting of reservoir stages, flow data, and reservoir releases at diversion dam, reservoir intake, and division works; and
- (4) reporting of unusual and/or unsatisfactory conditions of facilities and equipment.

During flood periods, the Project Manager (Damtender), or his authorized representative, shall be on duty to cover 24-hours-a-day performance of operations for regulation of flood flows. The Hydrology Section will provide water control instructions to the Damtender during a major flood operation.

9-03. Flood Control District. The Mill Creek Flood Control District is administered by a Board of Directors, consisting of the elected County Commissioners of Walla Walla County. The Flood Control District is responsible for operation and maintenance of the improved Mill Creek channel from Gose Street upstream to the Corps of Engineers property line, which is about 300 feet below the first division structure.

9-04. Watermaster. The Watermaster for Walla Walla County represents the Washington State Department of Ecology Division of Water Resources. He is responsible for the distribution of Mill Creek waters in accordance with established water rights.

9-05. Communications. Communications between the Walla Walla District Corps of Engineers, Mill Creek Project office and local authorities are accomplished by telephone. Telephone numbers of persons responsible for flood control regulation are listed in the Emergency Regulation Assistance Procedures on pages iii and iv (pink sheets) in the front of this manual.

9-06. Public Information. The Corps of Engineers will provide public notices and public information news releases to local authorities and the general public. Public notices are required only when there is a pronounced departure from normal project operating procedures. Public notices will be issued by the Operations Division for special conditions which will affect the normal operation and use of project facilities sometime in the future. Public information news releases to the public on immediate water control activities will be issued through the Walla Walla District Public Affairs Officer.

9-07. Cooperative Stream Gaging Program with USGS. The Corps of Engineers has an on-going cooperative streamgaging program with the U.S. Geological Survey (USGS) to help fund on an annual basis the operation and maintenance of several USGS streamgaging station throughout the Walla Walla District. This program includes the funding for the operation and maintenance of three stream gages in the Mill Creek Basin. The gages are listed below.

USGS 14013000 – Mill Creek near Walla Walla, WA

USGS 14013700 – Mill Creek at Five Mile Rd. Bridge near Walla Walla, WA

USGS 14015000 – Mill Creek at Walla Walla, WA

ORGANIZATION CHART

**CHART 9-1
CORPS OF ENGINEERS - WALLA WALLA DISTRICT**

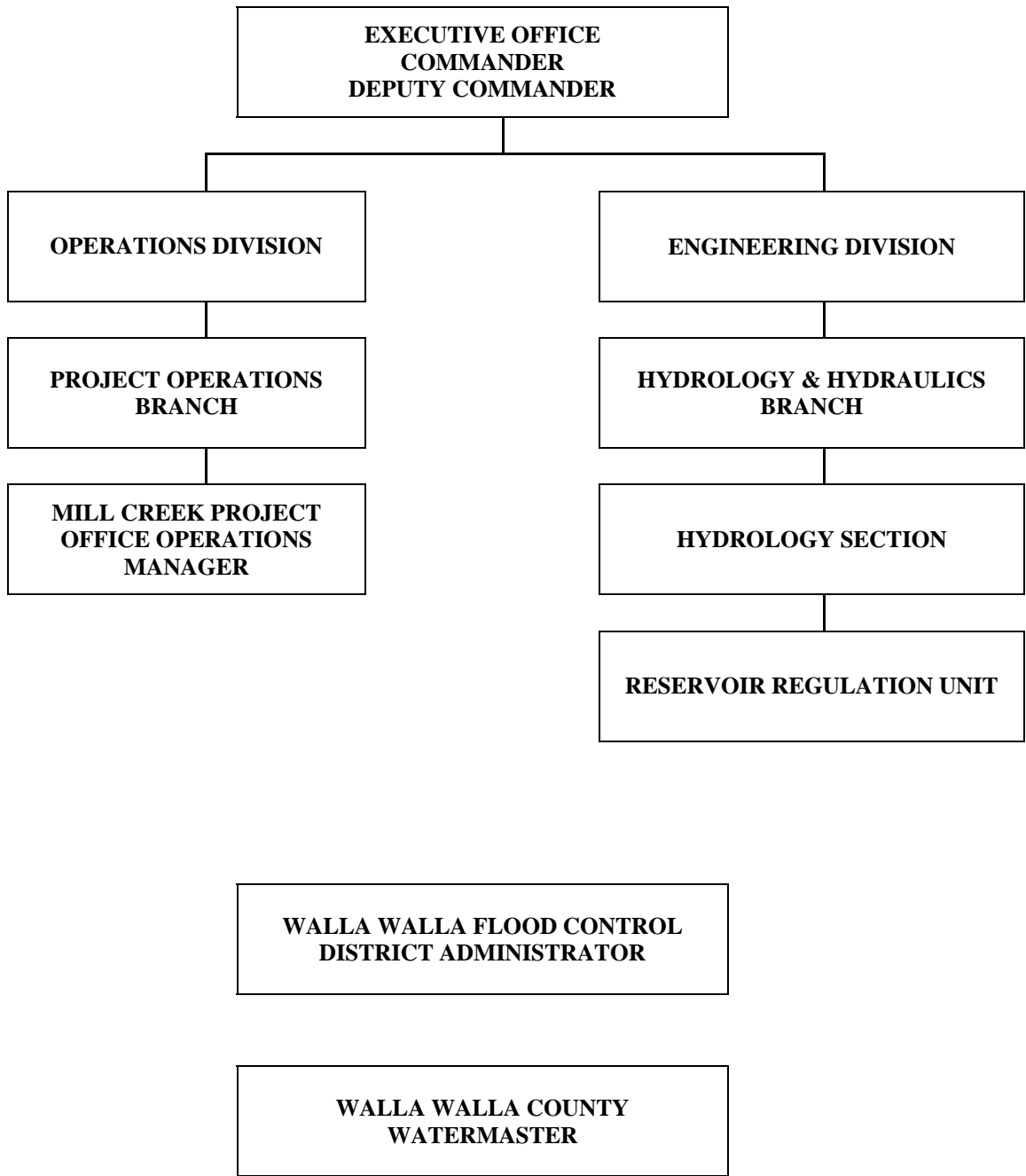

PERSONNEL AND PHONE NUMBERS [REDACTED] [REDACTED]

CHART 9-2

CORPS OF ENGINEERS - WALLA WALLA DISTRICT

TITLE	NAME	OFFICE	TELEPHONE
COMMANDER	LTC. ANTHONY J. HOFMANN	OFFICE	509-527-7700
DEPUTY COMMANDER	MAJ. DONALD A. PINCUS	OFFICE	509-527-7702
OPERATIONS DIVISION - CHIEF	WAYNE JOHN	OFFICE	509-527-7101
HYDRAULICS AND HYDROLOGY BRANCH - CHIEF	MARK LINDGREN	OFFICE	509-527-7530
HYDROLOGY SECTION - CHIEF	JOHN HEITSTUMAN	OFFICE [REDACTED]	509-527-7293 [REDACTED]
RESERVOIR REGULATION	EDWIN KIM	OFFICE [REDACTED]	509-527-7289 [REDACTED]
MILL CREEK PROJECT - OPERATIONS MANAGER	STEVEN THOMPSON	OFFICE [REDACTED] [REDACTED]	509-527-7161 [REDACTED] [REDACTED]

WALLA WALLA FLOOD CONTROL DISTRICT

TITLE	NAME	OFFICE	TELEPHONE
ADMINISTRATOR	STEVE H. STANTON	OFFICE	509-529-1273

WALLA WALLA COUNTY WATERMASTER

TITLE	NAME	OFFICE	TELEPHONE
DEPT. OF ECOLOGY - WATERMASTER	BILL NEVE	OFFICE	509-527-4546

PERSONNEL AND PHONE NUMBERS
CHART 9-2

CORPS OF ENGINEERS - WALLA WALLA DISTRICT

TITLE	NAME	OFFICE TELEPHONE	
COMMANDER	LTC. ANTHONY J. HOFMANN	OFFICE	509-527-7700
DEPUTY COMMANDER	MAJ. DONALD A. PINCUS	OFFICE	509-527-7702
OPERATIONS DIVISION - CHIEF	SCOTT ROSS	OFFICE	509-527-7101
HYDRAULICS AND HYDROLOGY BRANCH - CHIEF	MARK LINDGREN	OFFICE	509-527-7530
HYDROLOGY SECTION - CHIEF	JOHN HEITSTUMAN	OFFICE	509-527-7293 [REDACTED]
RESERVOIR REGULATION UNIT - CHIEF	EDWIN KIM	OFFICE	509-527-7289 [REDACTED]
MILL CREEK PROJECT - OPERATIONS MANAGER	STEVEN THOMPSON	OFFICE	509-527-7161 [REDACTED] [REDACTED]

WALLA WALLA FLOOD CONTROL DISTRICT

TITLE	NAME	OFFICE TELEPHONE	
ADMINISTRATOR	RANDY GLAESER	OFFICE	509-524-2710
		OFFICE	509-527-3241

WALLA WALLA COUNTY WATERMASTER

TITLE	NAME	OFFICE TELEPHONE	
DEPT. OF ECOLOGY - WATERMASTER	BILL NEVE	OFFICE	509-527-4546 [REDACTED]

UPDATED: May 22, 2007

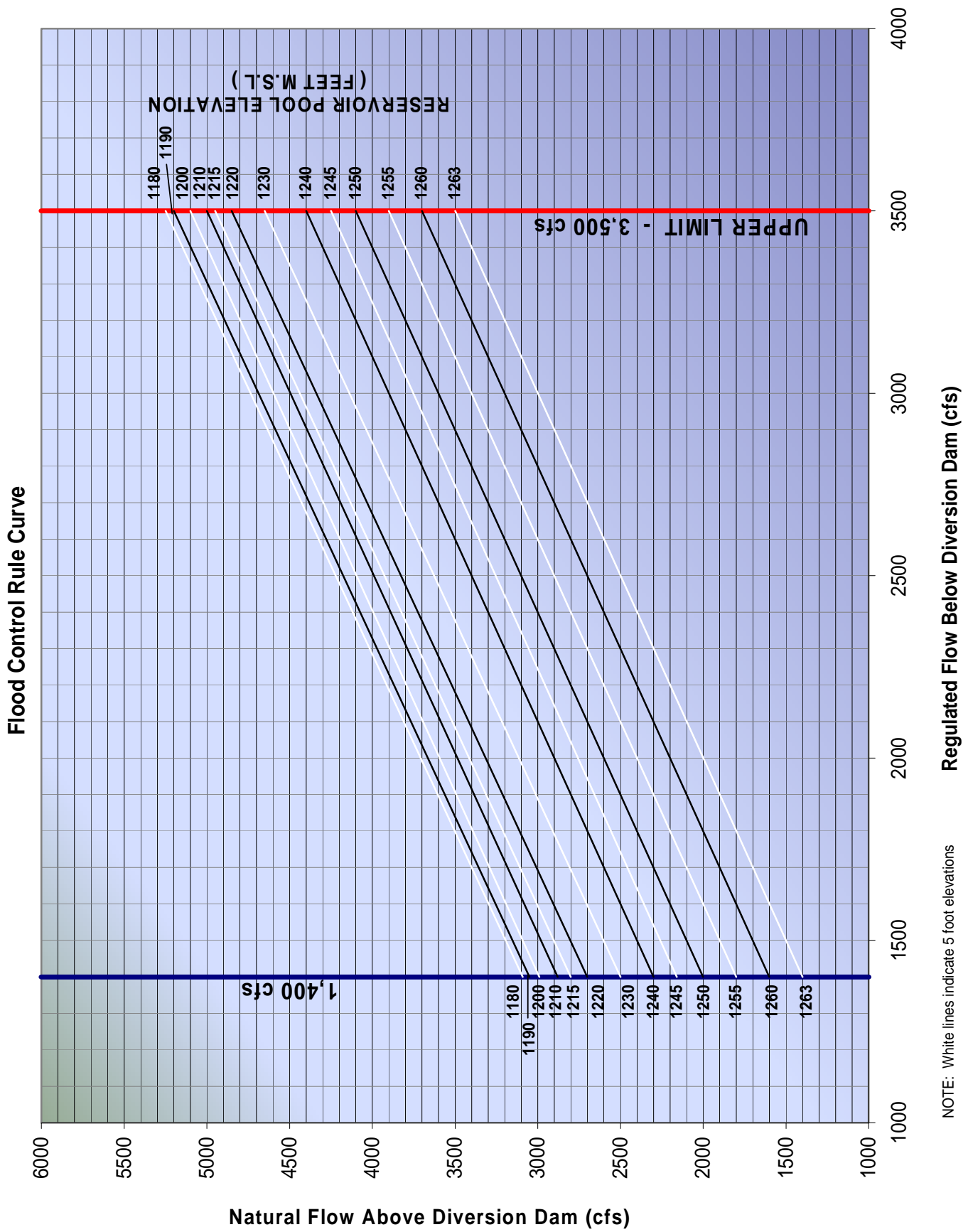

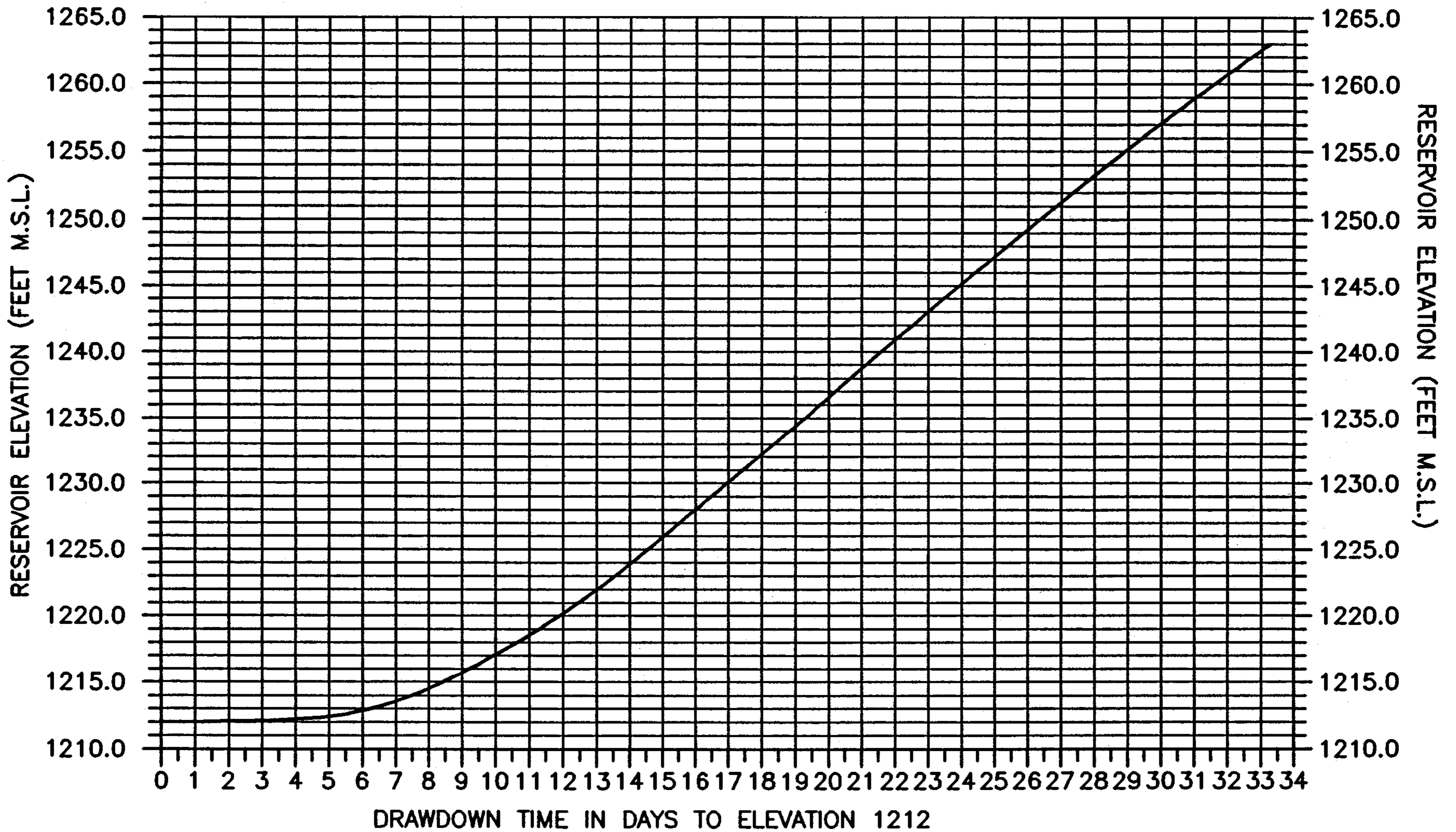

NOTES:

1. Derived from Discharge Curves by Hydraulic Design, dated 29 November 1979.
2. Mill Creek return outlet canal valve fully open.
3. Evaporation and seepage not taken into account.

MILL CREEK LAKE
Walla Walla, Washington
DRAWDOWN CURVE
(ELEVATION 1263 TO 1212)
U.S. ARMY CORPS OF ENGINEERS
WALLA WALLA DISTRICT - HYDROLOGY BRANCH
Prepared: G. Hardin
Checked By: E. Kim
Revised
January 1989

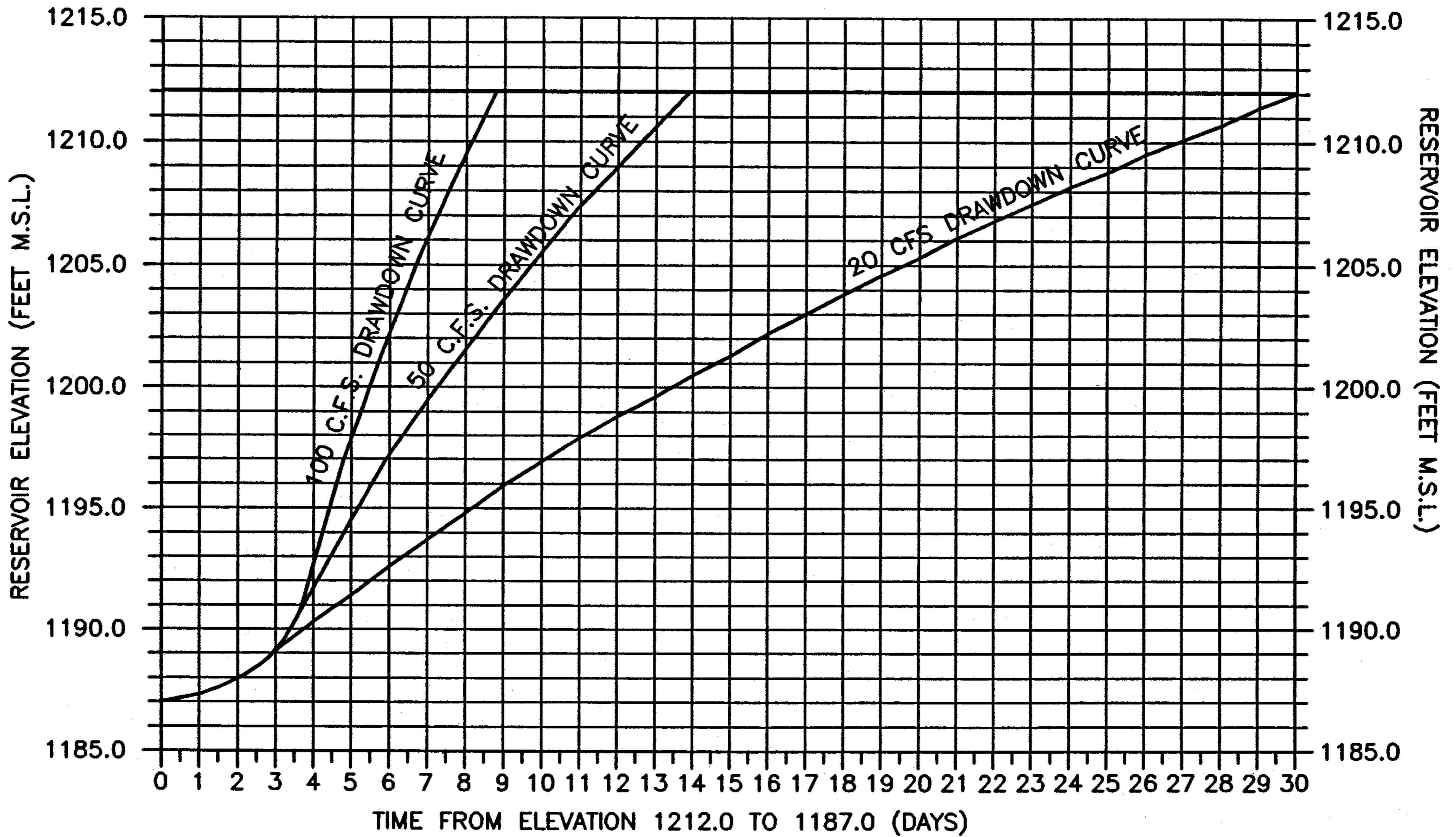

NOTES:

1. Derived from Discharge Curves by Hydraulic Design, dated 29 November 1979.
2. No discharge to Mill Creek return outlet canal.
3. Evaporation and seepage not taken into account.

MILL CREEK LAKE
Walla Walla, Washington

DRAWDOWN CURVE
(ELEVATION 1212 TO 1187)

U.S. ARMY CORPS OF ENGINEERS
WALLA WALLA DISTRICT - HYDROLOGY BRANCH

Prepared: G. Hardin
Checked By: E. Kim

Revised
January 1989

ORGANIZATION CHART

**CHART 9-1
CORPS OF ENGINEERS - WALLA WALLA DISTRICT**

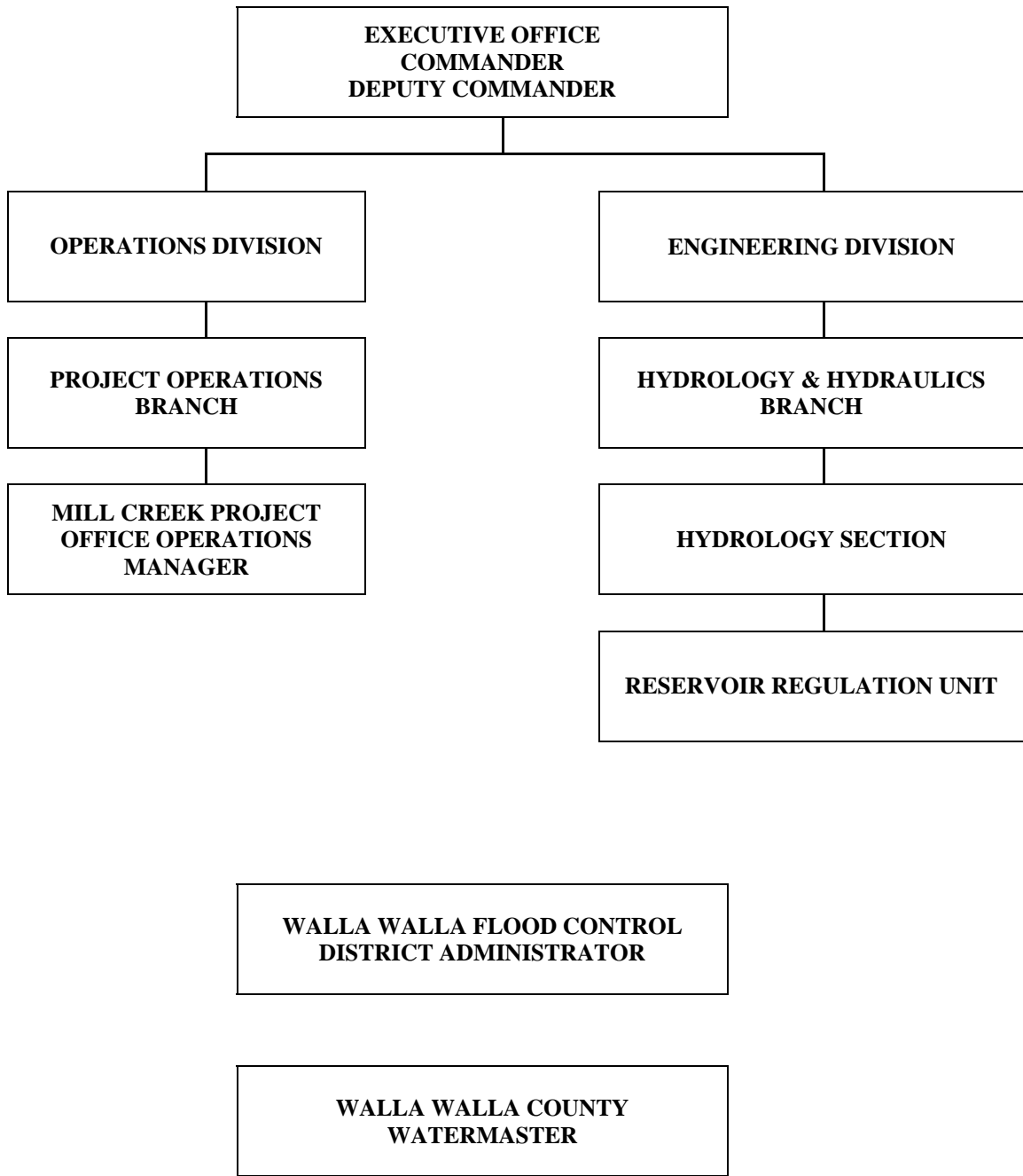

PERSONNEL AND PHONE NUMBERS
CHART 9-2

CORPS OF ENGINEERS - WALLA WALLA DISTRICT

TITLE	NAME	OFFICE TELEPHONE	
COMMANDER	LTC. ANTHONY J. HOFMANN	OFFICE	509-527-7700
DEPUTY COMMANDER	MAJ. NEIDIG, CHAD B	OFFICE	509-527-7702
OPERATIONS DIVISION - CHIEF	SCOTT ROSS	OFFICE	509-527-7101
HYDRAULICS AND HYDROLOGY BRANCH - CHIEF	MARK LINDGREN	OFFICE	509-527-7530
HYDROLOGY SECTION - CHIEF	JOHN HEITSTUMAN	OFFICE	509-527-7293
RESERVOIR REGULATION UNIT - CHIEF	EDWIN KIM	OFFICE	509-527-7289
MILL CREEK PROJECT - OPERATIONS MANAGER	STEVEN THOMPSON	OFFICE	509-527-7161

WALLA WALLA FLOOD CONTROL DISTRICT

TITLE	NAME	OFFICE TELEPHONE	
ADMINISTRATOR	RANDY GLAESER	OFFICE	509-524-2710
		OFFICE	509-527-3241

WALLA WALLA COUNTY WATERMASTER

TITLE	NAME	OFFICE TELEPHONE	
DEPT. OF ECOLOGY - WATERMASTER	BILL NEVE	OFFICE	509-527-4546

UPDATED: Dec 28, 2007

Figure 4-1
Regional Temperatures
Mill Creek Project (1971-2000)

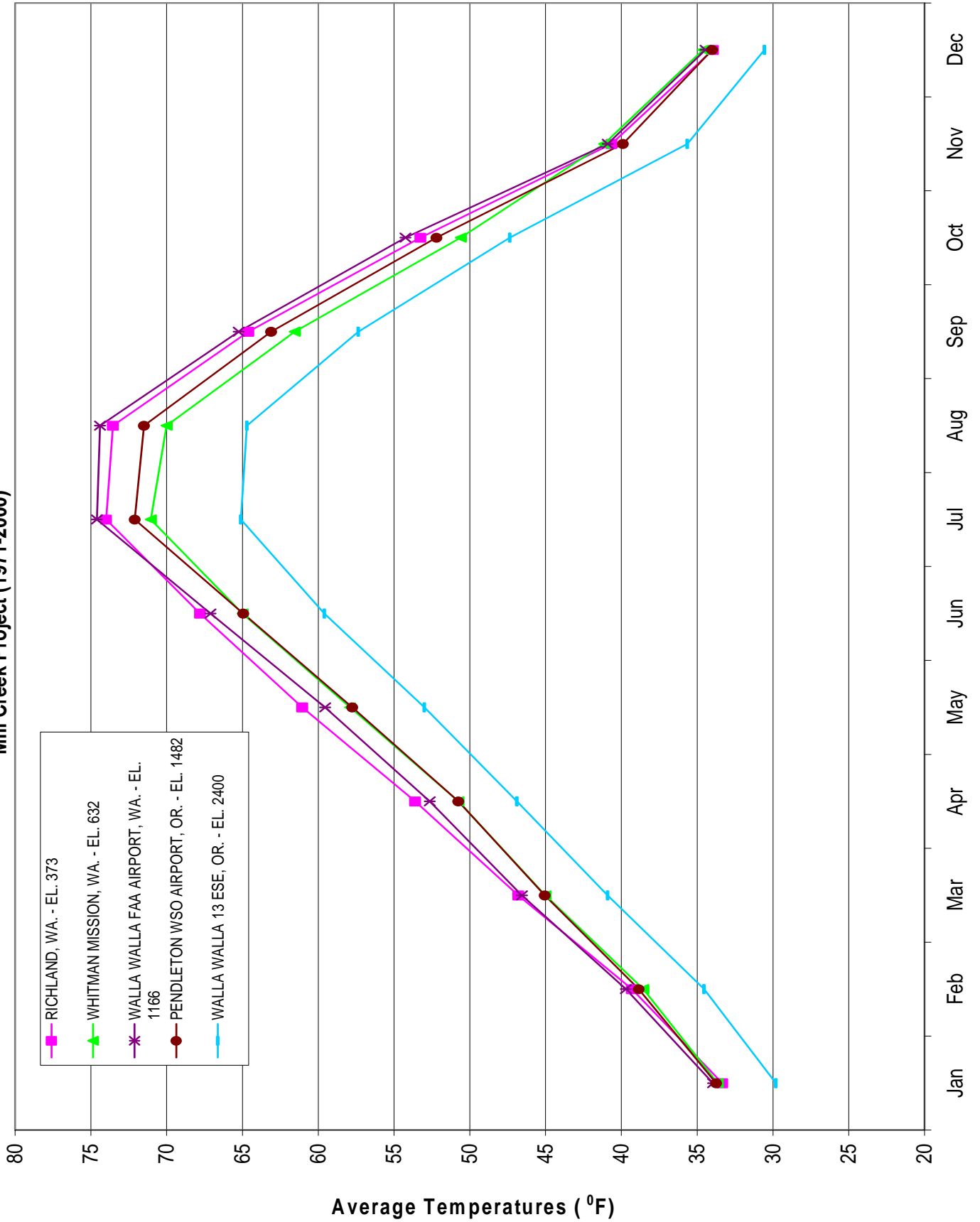

FIGURE 4 - 1

Figure 4-2
Regional Precipitation
Mill Creek Project (1971-2000)

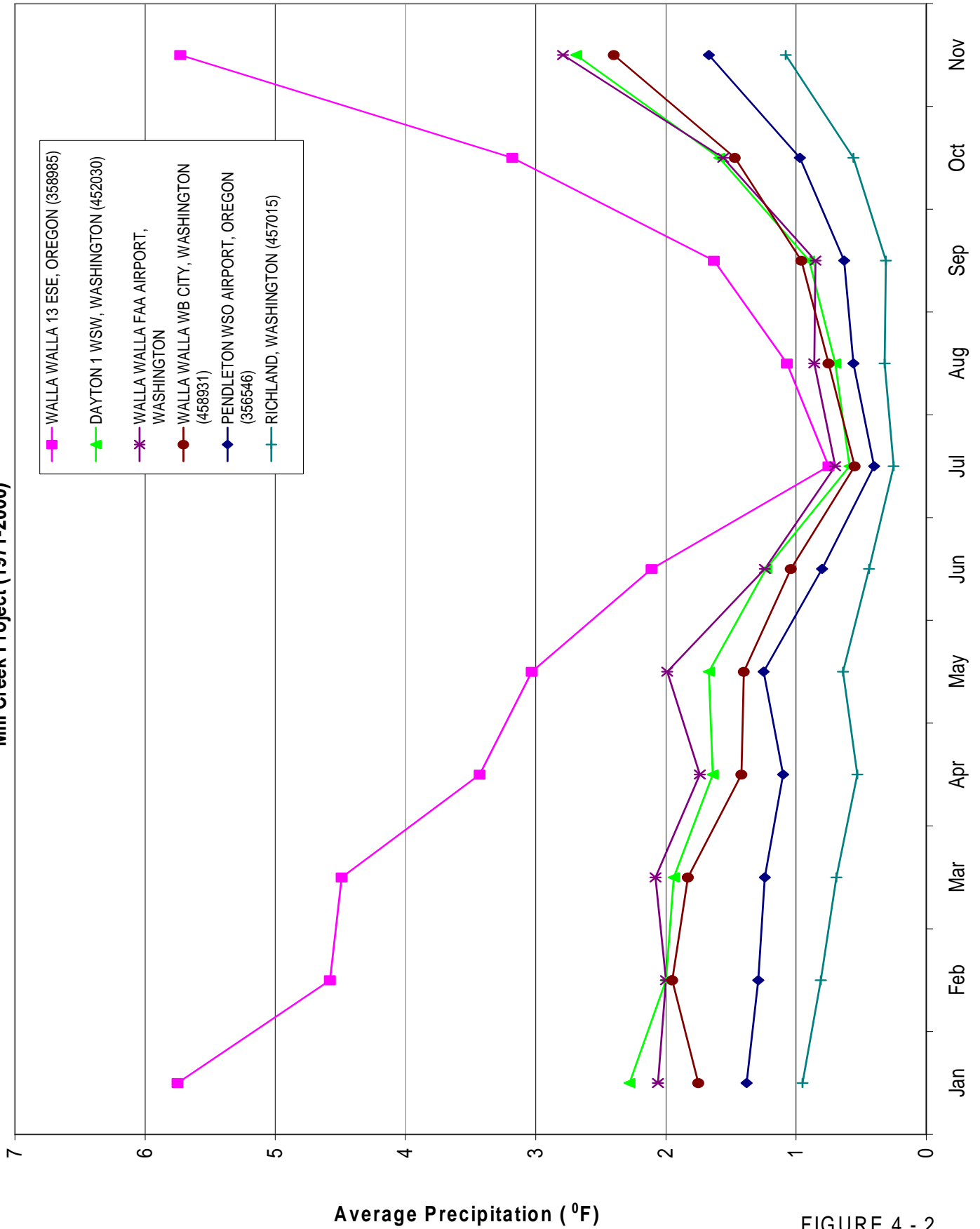

FIGURE 4 - 2

Figure 4-3
 Project Temperatures
 Mill Creek Project (1971-2000)

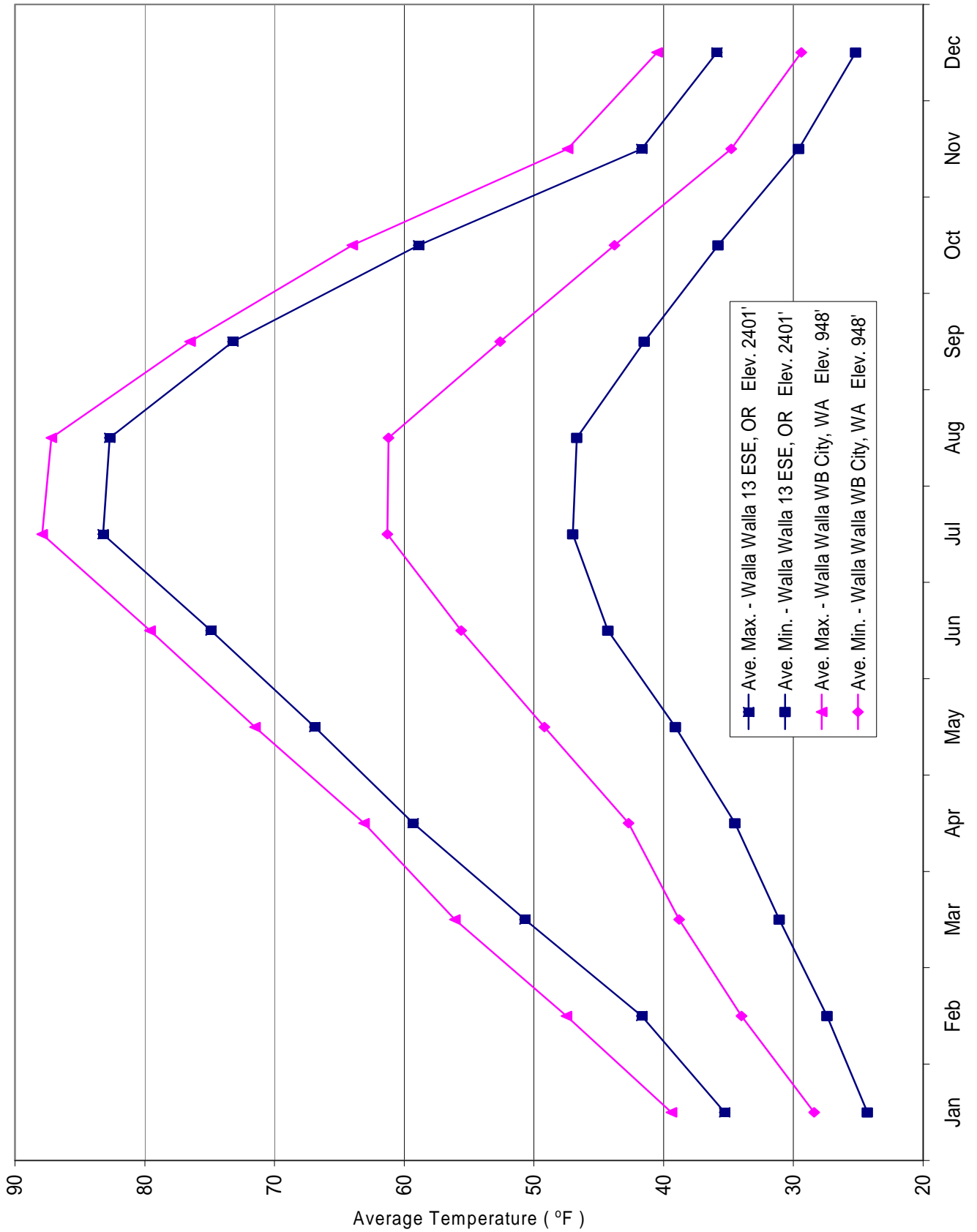
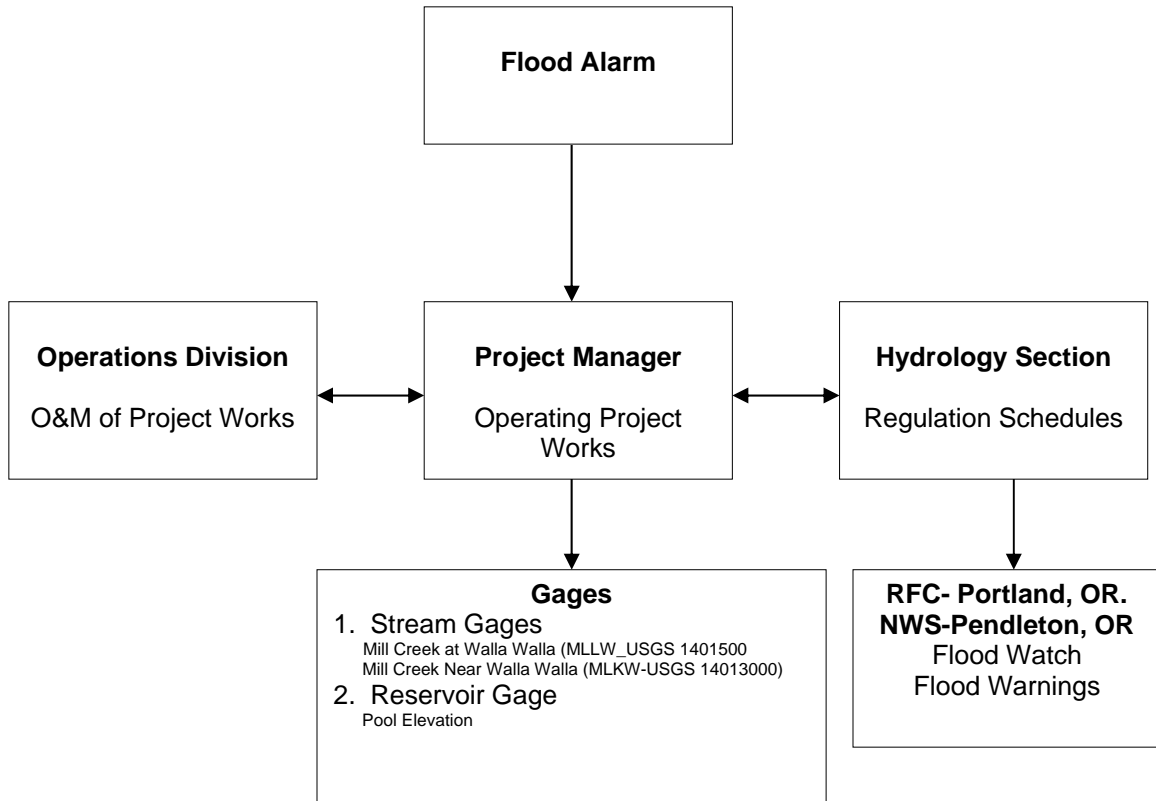
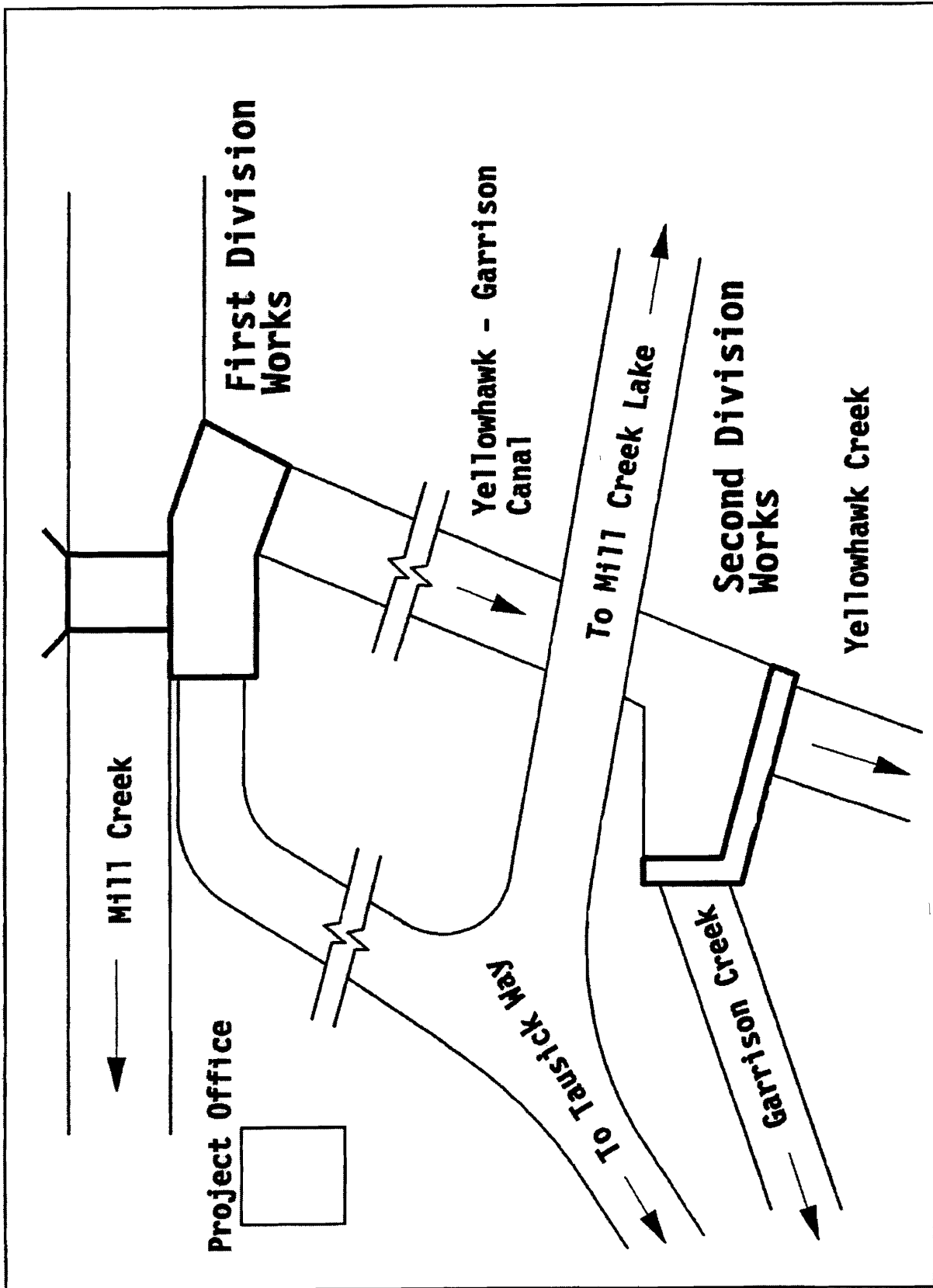

Figure 7-1
Mill Creek Project
Flood Control Plan-Operational Flow Chart





TABLES

No.

2-1 Reservoir Storage Capacity

2-2 Discharge Rating - Russell Creek Outlet Canal

4-1 Bennington Lake - Average Regional Temperatures

4-2 Bennington Lake - Regional Precipitation

4-3 Monthly Precipitation - Walla Walla WSO, WA.

4-4 Monthly Precipitation - Walla Walla 13 ESE, OR.

4-5 Total Monthly Evaporation - Whitman Mission

4-6 Total Monthly Runoff Volume - Mill Creek at Walla Walla

4-7 Total Monthly Runoff Volume - Mill Creek near Walla Walla

7-1 Discharge Rating Table - Mill Creek at Walla Walla

7-2 Discharge Rating Table - Mill Creek near Walla Walla

TABLE 2-1
MILL CREEK RESERVOIR
STORAGE TABLE
18 JANUARY 1983
(ACRE-FEET)

	.0	.1	.2	.3	.4	.5	.6	.7	.8	.9
1180.00	16	17	19	20	22	23	24	26	27	29
1181.00	30	32	33	35	36	38	39	41	42	44
1182.00	45	47	48	50	51	53	55	56	58	59
1183.00	61	63	65	66	68	70	72	74	75	77
1184.00	79	81	83	85	87	90	92	94	96	98
1185.00	100	102	104	107	109	111	113	115	118	120
1186.00	122	124	127	129	132	134	136	139	141	144
1187.00	146	149	151	154	156	159	162	164	167	169
1188.00	172	175	178	181	184	187	190	193	196	199
1189.00	202	205	209	212	215	219	222	225	228	232
1190.00	235	238	242	245	249	252	255	259	262	266
1191.00	269	273	276	280	283	287	290	294	297	301
1192.00	304	308	311	315	318	322	325	329	332	336
1193.00	339	343	346	350	353	357	361	364	368	371
1194.00	375	379	382	386	389	393	397	400	404	407
1195.00	411	415	418	422	426	430	433	437	441	444
1196.00	448	452	456	460	464	468	471	475	479	483
1197.00	487	491	495	500	504	508	512	516	521	525
1198.00	529	534	538	543	547	552	556	561	565	570
1199.00	574	579	583	588	593	598	602	607	612	616
1200.00	621	626	630	635	640	645	649	654	659	663
1201.00	668	673	678	682	687	692	697	702	706	711
1202.00	716	721	726	731	736	741	745	750	755	760
1203.00	765	770	775	780	785	790	795	800	805	810
1204.00	815	820	825	830	835	841	846	851	856	861
1205.00	866	871	877	882	887	893	898	903	908	914
1206.00	919	925	930	936	941	947	953	958	964	969
1207.00	975	981	987	993	999	1005	1010	1016	1022	1028
1208.00	1034	1040	1046	1052	1058	1065	1071	1077	1083	1089
1209.00	1095	1101	1108	1114	1120	1127	1133	1139	1145	1152
1210.00	1158	1164	1171	1177	1183	1190	1196	1202	1208	1215
1211.00	1221	1227	1234	1240	1246	1253	1259	1265	1271	1278

	.0	.1	.2	.3	.4	.5	.6	.7	.8	.9
1212.00	1284	1290	1297	1303	1309	1316	1322	1328	1334	1341
1213.00	1347	1353	1360	1366	1372	1379	1385	1391	1397	1404
1214.00	1410	1416	1423	1429	1436	1442	1448	1455	1461	1468
1215.00	1474	1481	1487	1494	1501	1508	1514	1521	1528	1534
1216.00	1541	1548	1555	1562	1569	1577	1584	1591	1598	1605
1217.00	1612	1620	1627	1635	1642	1650	1657	1665	1672	1680
1218.00	1687	1695	1703	1711	1719	1727	1735	1743	1751	1759
1219.00	1767	1775	1784	1792	1801	1809	1817	1826	1834	1843
1220.00	1851	1860	1868	1877	1885	1894	1902	1911	1919	1928
1221.00	1936	1945	1953	1962	1970	1979	1988	1996	2005	2013
1222.00	2022	2031	2039	2048	2057	2066	2074	2083	2092	2100
1223.00	2109	2118	2127	2135	2144	2153	2162	2171	2179	2188
1224.00	2197	2206	2215	2224	2233	2242	2250	2259	2268	2277
1225.00	2286	2295	2304	2314	2323	2332	2341	2350	2360	2369
1226.00	2378	2387	2396	2406	2415	2424	2433	2442	2452	2461
1227.00	2474	2484	2494	2504	2514	2524	2533	2543	2553	2563
1228.00	2573	2583	2593	2604	2614	2624	2634	2644	2655	2665
1229.00	2675	2685	2696	2706	2717	2727	2737	2748	2758	2769
1230.00	2779	2790	2800	2811	2821	2832	2843	2853	2864	2874
1231.00	2885	2896	2907	2917	2928	2939	2950	2961	2971	2982
1232.00	2993	3004	3015	3026	3037	3048	3059	3070	3081	3092
1233.00	3103	3114	3125	3137	3148	3159	3170	3181	3193	3204
1234.00	3215	3227	3238	3250	3261	3273	3284	3296	3307	3319
1235.00	3330	3342	3354	3365	3377	3389	3401	3413	3424	3436
1236.00	3448	3460	3472	3484	3496	3508	3520	3532	3544	3556
1237.00	3568	3580	3593	3605	3617	3630	3642	3654	3666	3679
1238.00	3691	3704	3716	3729	3741	3754	3767	3779	3792	3804
1239.00	3817	3830	3843	3856	3869	3882	3894	3907	3920	3933
1240.00	3946	3959	3972	3986	3999	4012	4025	4038	4052	4065
1241.00	4078	4092	4105	4119	4132	4146	4159	4173	4186	4200
1242.00	4213	4227	4241	4254	4268	4282	4296	4310	4323	4337
1243.00	4351	4365	4379	4393	4407	4422	4436	4450	4464	4478
1244.00	4492	4506	4521	4535	4549	4564	4578	4592	4606	4621
1245.00	4635	4650	4664	4679	4694	4709	4723	4738	4753	4767
1246.00	4782	4797	4812	4827	4842	4857	4872	4887	4902	4917
1247.00	4932	4947	4963	4978	4994	5009	5024	5040	5055	5071
1248.00	5086	5102	5118	5133	5149	5165	5181	5197	5212	5228
1249.00	5244	5260	5276	5292	5308	5325	5341	5357	5373	5389

TABLE 2-2

RUSSELL CREEK OUTLET CANAL
 RATING TABLE
 April 5, 1979

Gage Reading	Discharge in cfs									
	0	.1	.2	.3	.4	.5	.6	.7	.8	.9
0	0	2	4	7	10	13	16	20	25	32
1	40	48	58	68	78	89	100	112	124	137
2	150	165	182	200	220	240	265	290	315	340

TABLE 4-1
 BENNINGTON LAKE
 AVERAGE REGIONAL TEMPERATURES
 (DEGREES F.)

STATION		JAN	FEB	MAR	APR	MAY	JUN	JUL	AUG	SEP	OCT	NOV	DEC	ANNUAL
RICHLAND, WA. (ELEVATION 357)	MAX	41.1	49.5	58.0	66.9	75.9	83.6	91.6	89.5	81.4	67.9	51.7	43.8	66.7
	MIN	25.9	31.3	34.6	40.8	48.3	55.1	59.8	58.6	51.1	41.3	33.6	29.3	42.5
	AVG	33.5	40.4	46.3	53.9	62.1	69.4	75.7	74.0	66.3	54.7	42.7	36.6	54.6
WALLA WALLA, WA. WSO (ELEVATION 949)	MAX	40.1	47.3	54.3	62.2	70.9	79.3	88.8	86.0	77.3	64.0	49.0	43.0	63.5
	MIN	28.4	33.9	37.3	42.4	49.3	55.8	62.2	61.2	53.6	44.5	35.9	31.4	44.7
	AVG	34.3	40.7	45.8	52.3	60.1	67.6	75.5	73.6	65.5	54.3	42.5	37.2	54.1
WALLA WALLA 13 ESE OREGON (ELEVATION 2400)	MAX	35.0	41.5	48.5	57.9	67.0	74.5	84.0	81.8	72.7	58.8	42.6	37.1	58.5
	MIN	23.9	28.0	29.4	33.5	38.8	44.2	46.3	45.9	41.5	36.1	30.2	26.7	35.4
	AVG	29.4	34.7	38.9	45.7	52.9	59.4	65.1	63.9	57.1	47.5	36.4	31.9	46.9
PENDLETON, OR. WSO AP (ELEVATION 1482)	MAX	39.4	46.9	53.4	61.4	70.6	79.6	88.9	85.9	77.1	63.7	48.7	42.5	63.2
	MIN	26.3	31.8	34.4	39.2	46.1	52.9	58.6	57.5	50.5	41.3	33.4	29.5	41.8
	AVG	32.8	39.4	43.9	50.3	58.4	66.2	73.8	71.7	63.8	52.5	41.1	36.0	52.5
MORO, OR. (ELEVATION 1868)	MAX	37.1	44.1	50.2	57.5	66.1	74.1	83.1	81.3	74.1	61.7	46.7	40.2	59.7
	MIN	23.0	28.6	30.8	35.1	41.2	48.1	53.4	52.3	45.8	37.0	30.3	26.5	37.7
	AVG	30.1	36.4	40.5	46.3	53.7	61.1	68.3	66.9	59.9	49.4	38.5	33.4	48.7

- NOTES: 1. Average Temperature Values Based on 30 Year Time Period (1951-1980).
 2. Source: Climatological Data, Oregon and Washington.

TABLE 4-2

BENNINGTON LAKE
AVERAGE REGIONAL PRECIPITATION (INCHES)

STATION	JAN	FEB	MAR	APR	MAY	JUN	JUL	AUG	SEP	OCT	NOV	DEC	ANNUA
RICHLAND, WA. (ELEVATION 357)	1.03	0.69	0.50	0.42	0.53	0.44	0.14	0.32	0.28	0.46	0.91	1.06	6.78
WALLA WALLA, WA. WSO (ELEVATION 949)	2.12	1.40	1.41	1.35	1.40	0.93	0.35	0.71	0.83	1.40	1.87	2.19	15.96
WALLA WALLA 13 ESE (ELEVATION 2400)	6.29	4.08	4.49	3.68	2.74	2.29	0.59	1.23	1.93	3.62	5.15	5.82	42.65
ELGIN, OR. (ELEVATION 2655)	3.22	2.37	2.22	1.71	1.79	1.39	0.54	0.78	1.14	1.94	3.02	3.66	23.78
PENDLETON, OR. WSO AP (ELEVATION 1482)	1.73	1.11	1.06	0.99	1.09	0.70	0.30	0.55	0.58	0.95	1.48	1.66	12.20
MORO, OR. (ELEVATION 1868)	1.83	1.04	1.01	0.73	0.85	0.65	0.24	0.42	0.47	0.77	1.63	1.74	11.38

1. Average precipitation values based on 30 year time period (1951-1980).
2. Source: Climatological Data, Oregon and Washington, 1985.

TABLE 4-3

MILL CREEK BASIN - MONTHLY PRECIPITATION
WALLA WALLA, WASHINGTON WSO (ELEVATION 949)

<u>WATER</u>													<u>WATER YEAR</u>		
<u>YEAR</u>	<u>OCT</u>	<u>NOV</u>	<u>DEC</u>	<u>JAN</u>	<u>FEB</u>	<u>MAR</u>	<u>APR</u>	<u>MAY</u>	<u>JUN</u>	<u>JUL</u>	<u>AUG</u>	<u>SEP</u>	<u>TOTAL</u>	<u>MAX</u>	<u>MIN</u>
1951	4.20	2.05	2.96	1.79	1.65	1.50	0.88	0.56	2.48	0.13	0.07	0.74	19.01	4.20	0.07
1952	2.77	0.89	1.26	1.22	1.75	1.25	1.10	0.70	2.33	0.00	0.02	0.49	13.78	2.77	0.00
1953	0.09	0.41	1.96	4.52	1.52	1.41	1.77	1.99	0.75	0.00	0.57	0.17	15.16	4.52	0.00
1954	1.32	1.97	1.94	2.21	0.60	1.30	1.13	0.81	1.34	0.13	0.96	0.61	14.32	2.21	0.13
1955	0.88	1.38	1.65	1.43	0.43	0.59	2.08	1.20	0.30	0.97	0.00	1.32	12.23	2.08	0.00
1956	3.03	3.16	2.49	3.29	1.63	0.97	0.11	2.03	.74	0.08	1.52	0.19	19.24	3.29	0.08
1957	2.08	0.53	1.82	1.76	1.10	2.94	0.56	4.19	1.05	0.00	0.15	0.97	17.15	4.19	0.00
1958	1.97	1.80	1.87	2.06	1.60	1.49	3.17	2.36	0.80	0.08	0.01	0.49	17.70	3.17	0.01
* 1959	0.44	1.39	3.35	4.00	2.25	1.50	0.85	1.53	1.19	0.05	0.99	2.41	19.95	4.00	0.05
1960	0.93	0.73	0.88	1.15	1.28	1.69	1.31	2.27	0.93	0.00	0.92	0.79	12.88	2.27	0.00
1961	1.51	2.29	0.88	0.98	3.01	2.00	1.36	1.56	0.87	0.01	0.39	0.14	15.00	3.01	0.01
1962	1.32	1.79	2.42	0.63	0.92	2.36	1.20	3.78	0.45	0.00	0.41	1.44	16.72	3.78	0.00
1963	2.99	1.76	2.40	0.93	1.60	0.78	1.86	0.67	0.20	0.49	0.66	0.92	15.26	2.99	0.20
1964	0.60	2.89	2.00	0.97	0.17	0.60	0.90	0.23	1.22	1.47	0.30	0.94	12.29	2.89	0.17
1965	0.66	3.51	4.31	3.29	0.55	0.34	1.68	0.74	0.87	0.59	2.52	0.42	19.48	4.31	0.34
1966	0.73	1.94	0.29	2.22	0.83	1.85	0.19	0.45	1.09	1.78	0.29	0.15	11.81	2.22	0.15
1967	0.87	2.72	2.60	2.11	0.36	1.99	1.66	1.46	0.31	0.00	0.00	0.70	14.78	2.72	0.00
1968	0.88	1.25	1.24	0.79	2.42	0.88	0.43	0.69	0.91	0.48	0.98	1.45	12.40	2.42	0.43
1969	1.62	2.64	3.77	4.17	1.21	0.73	2.88	1.10	0.76	0.01	0.00	0.45	19.34	4.17	0.00
1970	1.43	0.61	2.12	5.86	2.56	1.54	1.84	0.48	1.27	0.15	0.01	1.92	19.79	5.86	0.01

STATISTICS 1951-1980 (40 YEARS)

N	37	37	37	36	36	36	36	36	36	36	36	36	36
MEAN	1.55	2.06	2.22	2.02	1.64	1.67	1.34	1.42	1.02	0.42	0.66	0.92	16.78
MAXIMUM	4.20	4.24	4.31	5.86	3.19	4.17	3.26	4.19	3.01	1.78	2.94	2.41	24.33
MINIMUM	0.03	0.31	0.29	0.55	0.17	0.34	0.11	0.23	0.20	0.00	0.00	0.00	11.16

* Highest Year

** Lowest Year

Notes: 1. Water Year includes Oct, Nov, Dec of one year plus Jan through Sep of the following year (i.e., Water Year 1980 = October 1979 through September 1980).

2. Source: Climatological Data, Oregon.

TABLE 4-4

MILL CREEK BASIN - MONTHLY PRECIPITATION
WALLA WALLA 13 ESE (ELEVATION 2400)

<u>WATER</u>	<u>WATER YEAR</u>														
<u>YEAR</u>	<u>OCT</u>	<u>NOV</u>	<u>DEC</u>	<u>JAN</u>	<u>FEB</u>	<u>MAR</u>	<u>APR</u>	<u>MAY</u>	<u>JUN</u>	<u>JUL</u>	<u>AUG</u>	<u>SEP</u>	<u>TOTAL</u>	<u>MAX</u>	<u>MIN</u>
1951	7.55	6.39	6.11	6.26	4.70		0.85	1.31	4.46	0.61	0.00	1.73		7.55	0.00
1952	9.25	5.69	7.00	2.96	2.93	4.06	2.89	2.74	4.90	0.39	0.00	0.97	43.78	9.25	0.00
1953	0.37	1.03	4.48	13.32	5.18	4.73	3.44	3.39	2.05	0.00	1.49	0.41	39.89	13.32	0.00
1954	1.40	5.70	7.89	7.26	2.16	2.20	4.18	2.86	4.19	0.42	3.17	0.67	42.10	7.89	0.42
1955	1.51	2.85	4.58	2.97	2.52	5.54	4.05	1.92	0.61	2.46	0.00	2.69	31.70	5.54	0.00
1956	5.90	5.86	7.93	6.45	4.86	4.98	0.46	4.63	2.35	0.74	2.49	0.77	47.42	7.93	0.46
1957	4.58	3.06	6.66	3.01	6.40	5.53	4.42	4.36	1.30	0.03	0.36	0.80	40.51	6.66	0.03
1958	4.21	4.29	8.44	6.33	5.85	2.39	8.01	2.10	2.41	0.24	0.18	1.37	45.82	8.44	0.18
1959	3.03	8.75	8.36	8.25	3.05	5.53	3.42	3.52	1.98	0.69	1.64	6.73	54.95	8.75	0.69
1960	4.56	4.22	2.71	2.78	5.69	5.50	4.01	4.84	1.70	0.07	1.93	1.37	39.38	5.69	0.07
1961	3.26	7.98	2.83	2.95	9.85	7.21	3.73	2.79	1.64	0.09	0.78	2.12	45.23	9.85	0.09
1962	4.53	4.12	5.38	3.01	2.11	5.93	3.72	3.05	0.47	0.00	0.75	3.45	36.52	5.93	0.00
1963	4.91	4.49	2.89	2.04	4.13	4.50	4.62	1.12	1.50	0.62	0.47	1.87	33.16	4.91	0.47
1964	1.28	7.19	3.49	9.40	2.07	5.58	3.86	1.22	2.27	0.95	1.15	2.41	40.87	9.40	0.95
1965	2.26	8.15	12.93	10.19	3.473	0.72	3.49	2.57	2.76	1.33	2.93	1.71	52.47	12.93	0.72
1966	1.53	3.59	1.48	8.04	5.05	6.45	1.36	1.57	2.04	1.79	0.88	0.68	34.46	8.04	0.68
1967	3.91	5.57	4.54	8.28	1.95	4.32	3.18	2.82	1.13	0.05	0.00	0.98	36.73	8.28	0.00
1968	4.75	2.96	4.80	2.47	6.57	2.28	2.93	3.01	2.58	1.13	3.97	4.27	41.72	6.57	1.13
1969	4.73	5.91	6.58	9.79	2.20	3.03	5.51	1.92	2.86	0.00	0.00	1.50	44.03	9.79	0.00
1970	2.98	1.56	5.30	12.64	4.00	5.10	4.83	1.89	3.27	0.81	0.33	3.84	46.55	12.64	0.33

WATERWATER YEAR

<u>YEAR</u>	<u>OCT</u>	<u>NOV</u>	<u>DEC</u>	<u>JAN</u>	<u>FEB</u>	<u>MAR</u>	<u>APR</u>	<u>MAY</u>	<u>JUN</u>	<u>JUL</u>	<u>AUG</u>	<u>SEP</u>	<u>TOTAL</u>	<u>MAX</u>	<u>MIN</u>
1971	4.60	7.91	3.59	7.93	3.48	5.40	2.70	4.57	4.09	1.06	0.80	4.31	50.44	7.93	0.80
1972	5.27	5.49	7.65	4.34	6.07	5.92	4.78	2.63	1.49	0.04	0.57	2.19	46.44	7.65	0.04
* 1973	1.70	2.65	8.82	4.55	2.08	2.58	1.26	2.14	1.18	0.00	0.36	4.08	31.40	8.82	0.00
** 1974	3.24	12.83	9.51	10.29	4.72	6.07	7.16	2.41	3.98	1.12	0.00	0.00	61.33	12.83	0.00
1975	0.00	4.93	6.22	9.74	4.23	4.63	4.04	1.96	2.06	0.62	1.72	0.00	40.15	9.74	0.00
1976	4.96	7.08	3.78								2.92	0.05		7.08	0.05
1977		2.82	2.34	1.48	2.05	4.32	0.86	3.39	0.85	0.20	4.42	2.89		4.42	0.20
1978	0.91	3.58	7.75	3.43	3.74	2.11	5.85	2.97						7.75	0.91
1979		4.65						2.51	1.19	0.22	1.04	0.23		4.65	0.22
1980	4.19	3.12	4.65	5.95	3.04	4.52	3.44	3.31	2.89	0.70	1.35	1.92	39.08	5.95	0.70
1981	2.12	5.47	5.23	1.08	4.85	4.11	3.33	2.62	2.33	0.54	0.01	1.63	33.32	5.47	0.01
1982	4.68	5.97	8.16	7.81	9.16	5.53	3.57	1.93	1.54	1.70	0.99	3.05	54.09	8.16	0.99
1983				6.09	5.22	7.35	2.16	3.56	1.98	2.43	0.80	1.94		7.35	0.80
1984	1.81				4.94	7.38	2.86	4.10	4.03	0.48	1.63	1.48		7.38	0.48
1985	1.87	2.58	2.00	0.52	3.32	2.87	2.54	1.83	1.97	0.44	1.06	2.88		3.32	0.44
1986	3.34	3.73	1.23	5.87	8.38	1.72								8.38	1.81
1987	1.26	8.66	1.35	4.64	3.61	3.86	2.62	2.42	1.19	0.72	0.60	0.39	31.32	8.66	0.39
1988	0.00	2.66	5.55	6.09	1.88	6.33	3.30	2.33	1.68	0.29	0.00	1.10	31.21	6.33	0.00
1989	0.47	11.21	3.90	7.95	1.53	6.01	1.83	3.94	1.43	0.28	2.61	0.62	41.78	11.21	0.47
1990	2.43	4.46	2.95		3.54	2.68	5.21	4.19	2.15	0.89	0.52				0.52

STATISTICS 1951-1980 (40 YEARS)

N	37	38	37	36	38	37	37	38	37	37	38	37	30
MEAN	3.23	5.24	5.38	6.00	4.22	4.65	3.53	2.69	2.23	0.65	1.14	1.87	41.93
MAXIMUM	9.25	12.83	12.93	13.32	9.85	7.38	8.01	4.84	4.90	2.46	4.42	6.73	61.33
MINIMUM	0.00	1.03	1.23	0.52	1.53	0.72	0.46	1.12	0.47	0.00	0.00	0.00	25.73

* Highest Year

** Lowest Year

Notes: 1. Water Year includes Oct, Nov, Dec of one year plus Jan through Sep of the following year (*i.e.*, Water Year 1980 = October 1979 through September 1980).

2. Source: Climatological Data, Oregon.

TABLE 4-5

BENNINGTON LAKE - TOTAL MONTHLY EVAPORATION
WHITMAN MISSION, WA. (ELEVATION 623)

YEAR	APR	MAY	JUN	JUL	AUG	SEP	APR-SEP TOTAL
1963	4.22	6.65	10.47	10.49	9.63	5.93	47.39
1964	5.84	7.10	8.77	10.43	9.09	6.00	47.23
1965	5.06	6.71	9.10	10.87	9.01	5.84	46.59
1966	5.43	7.27	8.72	10.23	9.98	6.12	47.75
1967	3.67	6.21	7.77	11.86	10.97	6.80	47.28
1968	5.01	7.49	8.99	11.43	7.74	5.28	45.94
1969	4.06	6.28	9.18	10.95	9.78	5.82	46.07
1970	4.64	7.21	8.21	10.97	10.35	5.68	47.06
1971	4.75	6.92	6.71	10.73	9.95	5.02	44.08
1972	4.81	6.63	8.46	10.14	8.86	5.99	44.89
1973	5.57	8.07	9.05	11.83	10.67	5.65	50.84
1974	4.31	7.10	9.61	9.90	9.97	6.68	47.57
1975	4.36	6.79	7.63	9.93	9.41	5.90	44.02
1976	3.74	7.05	7.86	10.25	7.38	6.10	42.38
1977	6.59	6.51	10.23	11.83	10.17	4.64	49.97
1978	4.11	6.84	9.91	9.84	8.38	4.57	43.65
* 1979	5.04	7.81	10.33	12.63	9.10	6.40	51.31
1980	5.40	5.49	7.31	10.31	9.33	5.46	43.30
1981	5.00	5.64	6.56	10.97	9.43	6.16	43.76
1982	4.78	6.73	7.79	9.90	8.97	4.48	42.65
1983	4.30	6.42	7.61	8.98	8.09	4.91	40.31
** 1984	4.27	5.30	6.40	9.69	8.73	4.82	39.21
1985	4.53	6.83	8.97	11.61	7.58	4.12	43.64
1986	4.68	6.50	9.30	9.55	9.49	4.84	44.36
1987							
1988	4.81	6.81	7.75	10.85	10.29	6.13	46.64
1989	4.77	6.00	9.00	10.13	8.14	5.58	43.62
1990	5.14	5.85	7.84	10.30	8.19		
STATISTICS 1963 - 1985 (33 Years)							
N	27	27	27	27	27	27	27
MEAN	4.77	6.67	8.50	10.69	9.24	5.58	45.52
MAXIMUM	6.59	8.07	10.47	12.63	10.97	6.80	51.31
MINIMUM	3.67	5.30	6.40	8.98	7.38	4.12	39.21
* Highest Year							
** Lowest Year							

Source: Climatological Data, Washington.

TABLE 4-6

MILL CREEK AT WALLA WALLA, WASHINGTON
Total Monthly Runoff Volume In 1,000 Acre-Feet

YEAR	OCT	NOV	DEC	JAN	FEB	MAR	APR	MAY	JUN	JUL	AUG	SEP	TOTAL	NOV- FEB	%	MAR- JUN	%
1942	0.375	2.588	5.586	5.008	6.567	6.020	3.273	4.384	3.858	0.528	0.317	0.438	38.942	19.749	51%	17.535	45%
1943	0.643	3.667	11.709	7.135	11.615	6.843	14.236	7.936	2.017	0.184	0.290	0.196	66.471	34.126	51%	31.032	47%
1944	1.099	1.410	2.146	0.974	3.582	8.585	9.346	2.436	0.403	0.105	0.139	0.123	30.348	8.112	27%	20.770	68%
1945	0.367	0.319	0.280	3.917	10.449	9.069	11.254	6.942	2.200	0.171	0.103	0.228	45.299	14.965	33%	29.465	65%
1946	0.230	2.668	9.660	16.798	10.163	15.017	6.458	5.096	1.595	0.349	0.300	0.325	68.659	39.289	57%	28.166	41%
1947	0.407	5.270	8.039	7.972	0.887	0.179	0.547	0.904	0.371	0.137	0.252	0.472	25.437	22.168	87%	2.001	8%
1948	1.029	8.727	6.901	8.882	6.865	7.101	14.722	21.180	5.223	0.339	0.333	0.214	81.516	31.375	38%	48.226	59%
1949	0.214	1.160	2.856	3.243	11.447	19.625	14.769	9.437	1.214	0.260	0.278	0.274	64.777	18.706	29%	45.045	70%
1950	0.403	0.655	2.009	5.346	18.298	20.714	11.324	6.615	7.006	0.226	0.077	0.103	72.776	26.308	36%	45.659	63%
1951	0.825	8.132	9.525	12.990	18.460	10.280	7.976	4.393	5.227	0.278	0.284	0.173	78.543	49.107	63%	27.876	35%
1952	15.895	2.771	6.863	3.602	10.760	7.065	16.421	5.962	0.692	0.591	0.054	0.093	60.769	23.996	39%	30.140	50%
1953	0.165	0.194	0.276	16.045	12.609	12.794	9.479	7.539	4.013	0.438	0.317	0.345	64.214	29.124	45%	33.825	53%
1954	0.339	0.662	8.712	7.472	8.474	3.713	8.493	2.009	6.748	0.252	0.230	0.200	47.304	25.320	54%	20.963	44%
1955	0.113	0.391	0.768	1.563	1.662	2.793	10.628	9.856	1.537	0.363	0.121	0.177	29.972	4.384	15%	24.814	83%
1956	0.192	3.035	15.204	11.088	4.804	14.418	11.480	6.605	1.377	0.381	0.040	0.010	68.634	34.131	50%	33.880	49%
1957	0.294	0.478	6.778	2.073	9.396	14.969	11.554	7.674	0.504	0.133	0.119	0.115	54.087	18.725	35%	34.701	64%
1958	0.052	0.428	7.295	10.398	16.378	4.614	17.451	7.440	1.507	0.246	0.123	0.127	66.059	34.499	52%	31.012	47%
1959	0.024	3.777	12.623	17.009	8.416	11.072	9.945	5.976	1.022	0.061	0.065	0.474	70.464	41.825	59%	28.015	40%
1960	1.335	3.336	2.596	2.743	8.571	9.455	8.795	5.893	0.754	0.141	0.208	0.129	43.956	17.246	39%	24.897	57%
1961	0.087	3.009	2.501	3.142	16.451	18.885	7.755	5.994	0.807	0.190	0.232	0.214	59.267	25.103	42%	33.441	56%
1962	0.135	1.031	6.212	5.516	2.705	10.584	10.677	4.395	0.474	0.093	0.083	0.071	41.976	15.464	37%	26.130	62%
1963	1.722	3.193	5.927	2.440	8.819	5.104	7.601	1.591	0.000	0.016	0.004	0.002	36.419	20.379	56%	14.296	39%
1964	0.000	0.561	2.017	6.589	4.655	6.980	12.056	7.313	2.023	0.093	0.054	0.038	42.379	13.822	33%	28.372	67%
1965	0.032	3.717	26.611	19.462	12.756	5.849	8.803	2.418	1.216	0.115	0.087	0.034	81.100	62.546	77%	18.286	23%
1966	0.002	0.058	0.583	5.994	4.830	15.354	9.299	1.531	0.097	0.071	0.091	0.048	37.958	11.465	30%	26.281	69%
1967	0.008	0.879	5.201	12.855	5.058	6.127	5.992	7.960	0.242	0.073	0.133	0.107	44.635	23.993	54%	20.321	46%
1968	0.044	0.010	3.842	4.520	12.425	2.596	2.906	0.030	0.052	0.058	0.061	0.028	26.572	20.797	78%	5.584	21%

YEAR	OCT	NOV	DEC	JAN	FEB	MAR	APR	MAY	JUN	JUL	AUG	SEP	TOTAL	NOV- FEB	%	MAR- JUN	%
1969	0.532	4.812	7.619	18.595	6.500	11.235	17.814	8.400	0.504	0.004	0.000	0.000	76.015	37.526	49%	37.953	50%
1970	0.008	0.002	1.339	22.691	12.304	11.461	8.386	6.187	1.571	0.044	0.030	0.089	64.112	36.336	57%	27.605	43%
1971	0.371	5.802	5.907	16.997	8.146	10.152	8.523	5.835	4.556	0.401	0.077	0.672	67.439	36.852	55%	29.066	43%
1972	0.274	3.013	10.471	10.146	15.110	24.070	10.344	7.732	1.051	0.115	0.050	0.006	82.382	38.740	47%	43.197	52%
1973	0.000	0.155	5.980	8.521	4.334	6.002	1.966	0.079	0.000	0.000	0.000	0.026	27.063	18.990	70%	8.047	30%
1974	0.012	9.055	23.086	22.892	13.813	15.368	22.687	13.448	10.645	0.813	0.000	0.000	131.819	68.846	52%	62.148	47%
1975	0.000	0.476	4.560	20.202	8.206	12.437	8.116	11.231	2.898	0.494	0.012	0.000	68.632	33.444	49%	34.682	51%
1976	0.135	2.051	21.102	21.273	11.350	12.472	19.303	8.212	2.162	0.020	0.111	0.034	98.225	55.776	57%	42.149	43%
1977	0.248	0.559	0.809	1.906	0.661	4.413	3.711	0.494	0.000	0.010	0.105	0.020	12.936	3.935	30%	8.618	67%
1978	0.034	2.551	14.160	10.536	9.013	6.825	7.553	4.336	0.000	0.048	0.054	0.014	55.124	36.260	66%	18.714	34%
1979	0.000	0.272	4.727	2.690	12.851	12.121	13.289	8.511	0.317	0.077	0.032	0.016	54.903	20.540	37%	34.238	62%
1980	0.119	0.296	3.376	10.015	7.791	9.509	7.579	2.386	1.660	0.000	0.000	0.000	42.731	21.478	50%	21.134	49%
1981	0.042	1.446	10.673	3.410	16.477	7.523	14.329	4.205	8.795	1.127	0.000	0.000	68.027	32.006	47%	34.852	51%
1982	0.214	2.079	10.150	14.184	27.170	15.739	12.425	7.333	1.882	0.268	0.002	0.133	91.579	53.583	59%	37.379	41%
1983	0.625	2.751	7.067	12.113	12.224	13.676	7.599	5.421	0.339	0.026	0.000	0.056	61.897	34.155	55%	27.035	44%
1984	0.030	2.807	6.460	13.484	10.062	20.402	6.657	5.958	9.622	0.829	0.186	0.157	76.654	32.813	43%	42.639	56%
1985	0.260	5.933	7.398	3.808	5.988	9.346	15.646	6.803	1.974	0.012	0.006	0.000	57.174	23.128	40%	33.769	59%
1986	0.748	2.460	3.068	8.593	20.053	14.882	4.721	4.221	0.956	0.335	0.127	0.353	60.517	34.174	56%	24.780	41%
1987	0.569	5.869	2.327	3.491	10.048	10.263	4.532	1.502	0.040	0.004	0.095	0.000	38.740	21.735	56%	16.336	42%
MEAN	0.440	2.489	7.022	9.355	9.983	10.515	9.966	5.909	2.199	0.229	0.115	0.138	58.359	28.849	49%	28.589	49%
MAXIMUM	5.895	9.055	26.611	22.892	27.170	24.070	22.687	21.180	10.645	1.127	0.333	0.672	131.819	68.846	52%	62.148	47%
MINIMUM	0.000	0.002	0.276	0.974	0.661	0.179	0.547	0.030	0.000	0.000	0.000	0.000	12.936	3.935	30%	2.001	15%

TABLE 4-7

MILL CREEK NEAR WALLA WALLA, WASHINGTON
Total Monthly Runoff Volume In 1,000 Acre-Feet

YEAR	OCT	NOV	DEC	JAN	FEB	MAR	APR	MAY	JUN	JUL	AUG	SEP	TOTAL	NOV- FEB	%	MAR- JUN	%
1914	2.890	3.925	2.660	7.355	7.805	11.173	7.968	4.943	2.995	2.184	2.003	2.166	58.067	21.745	37%	27.07	
1915	2.337	2.981	2.079	2.493	5.625	7.625	7.726	9.118	2.944	1.833	1.498	1.436	47.693	13.178	28%	27.41	
1916	1.743	4.292	7.234	3.987	11.590	19.377	11.746	10.314	5.861	3.128	1.888	1.734	82.894	27.103	33%	47.29	
1917	1.775	2.303	4.463	4.996	6.438	4.391	24.992	30.467	12.718	3.753	1.926	1.835	100.058	18.201	18%	72.56	
1940	1.194	1.432	2.307	3.068	11.425	10.628	9.789	4.639	1.987	1.706	1.642	1.720	51.537	18.232	35%	27.04	
1941	1.769	3.394	5.348	4.925	2.761	2.793	2.767	5.131	4.743	2.204	1.619	1.708	39.160	16.427	42%	15.43	
1942	2.204	5.125	6.863	3.318	5.478	6.228	6.528	7.131	6.272	2.731	1.513	1.343	54.735	20.785	38%	26.15	
1943	1.660	5.351	10.653	6.438	9.324	8.404	14.424	9.812	5.586	2.565	1.785	1.603	77.606	31.768	41%	38.22	
1944	2.491	2.876	3.451	2.071	4.098	7.997	9.269	5.304	2.773	1.642	1.515	1.688	45.176	12.496	28%	25.34	
1945	1.646	2.001	2.116	6.306	7.563	8.501	11.205	10.163	4.990	2.009	1.712	1.894	60.108	17.986	30%	34.86	
1946	1.930	6.073	8.946	10.209	7.942	12.411	11.330	9.402	5.066	3.285	2.099	1.948	80.639	33.170	41%	38.20	
1947	3.003	8.144	14.735	9.806	6.306	9.065	10.699	5.213	3.039	2.239	1.872	2.019	76.141	38.992	51%	28.01	
1948	3.733	9.816	8.987	9.689	11.211	6.754	12.171	18.954	7.071	3.312	2.567	2.448	96.713	39.704	41%	44.95	
1949	2.384	4.830	6.484	3.610	8.299	15.959	16.872	13.002	4.471	2.870	2.380	2.166	83.327	23.223	28%	50.30	
1950	2.509	3.065	4.237	5.578	14.846	19.512	13.466	13.873	9.729	3.701	2.866	2.642	96.023	27.725	29%	56.57	
1951	3.568	8.596	10.693	10.334	13.410	9.197	9.505	6.423	6.518	2.787	2.547	2.374	85.953	43.034	50%	31.64	
1952	6.480	6.333	7.845	4.945	10.074	8.600	16.463	10.035	4.562	3.804	2.348	2.194	83.684	29.197	35%	39.66	
1953	2.333	2.120	2.390	13.859	10.239	11.090	10.526	9.015	5.586	2.836	2.358	2.176	74.528	28.608	38%	36.21	
1954	2.303	3.037	9.449	8.364	8.208	5.768	9.804	5.431	7.297	2.553	2.323	2.178	66.715	29.058	44%	28.30	
1955	2.368	2.523	2.785	3.548	3.902	4.953	10.138	10.854	5.312	2.390	1.801	1.791	52.364	12.758	24%	31.25	
1956	2.164	4.671	12.163	9.035	4.622	10.701	13.214	9.572	3.499	2.186	1.952	1.807	75.585	30.490	40%	36.98	
1957	2.335	2.963	7.815	2.672	7.168	11.566	11.806	9.562	3.013	2.382	2.148	2.033	65.463	20.618	31%	35.94	
1958	2.323	3.158	8.126	9.071	15.045	5.879	16.043	11.231	3.336	2.293	2.055	2.025	80.584	35.400	44%	36.48	
1959	2.192	6.127	13.648	15.761	7.502	9.219	9.963	8.035	4.304	2.551	2.202	2.828	84.332	43.038	51%	31.52	
1960	4.294	6.847	4.594	4.163	8.107	9.368	9.088	7.567	3.719	2.112	2.503	2.426	64.789	23.711	37%	29.74	
1961	2.489	4.931	4.110	4.544	14.333	15.451	9.251	8.305	3.205	2.150	1.952	2.097	72.818	27.918	38%	36.21	
1962	2.130	3.061	6.363	6.690	4.316	9.138	11.129	7.075	3.197	1.932	1.726	1.841	58.599	20.430	35%	30.54	

YEAR	OCT	NOV	DEC	JAN	FEB	MAR	APR	MAY	JUN	JUL	AUG	SEP	TOTAL	NOV- FEB	%	MAR- JUN	%
1963	3.523	4.776	6.300	3.267	7.414	6.165	8.232	4.588	2.164	2.017	1.813	1.734	51.992	21.757	42%	21.14	
1964	1.753	3.598	4.380	6.385	5.022	6.877	12.264	11.276	4.866	2.144	1.847	1.775	62.187	19.385	31%	35.28	
1965	1.864	5.008	23.094	22.285	11.994	5.889	10.689	6.026	4.090	2.257	2.021	1.978	97.195	62.381	64%	26.69	
1966	1.954	2.023	2.023	5.088	4.227	11.629	9.769	5.786	2.551	1.985	1.531	1.450	50.016	13.361	27%	29.73	
1967	1.829	2.704	5.738	10.915	4.717	6.105	6.103	8.759	3.098	1.559	1.436	1.619	54.582	24.074	44%	24.06	
1968	1.942	2.075	5.223	4.883	11.532	4.169	4.862	3.148	1.993	1.438	1.535	1.787	44.587	23.713	53%	14.17	
1969	2.886	5.175	6.085	15.390	4.429	9.112	13.875	9.927	3.318	2.085	1.624	1.638	75.546	31.079	41%	36.23	
1970	1.870	1.680	3.398	17.173	9.503	9.221	7.823	8.537	4.171	2.285	1.984	1.928	69.573	31.754	46%	29.75	
1971	2.503	6.559	5.502	13.573	8.289	9.065	8.868	8.400	6.444	2.551	1.791	2.021	75.567	33.924	45%	32.77	
1972	1.978	4.520	7.640	8.963	13.184	22.043	10.725	10.768	4.497	3.237	2.471	2.575	92.602	34.309	37%	48.03	
1973	2.670	2.944	6.674	7.750	4.025	6.157	4.590	3.779	2.573	2.297	1.982	1.950	47.388	21.392	45%	17.09	
1974	2.235	8.862	16.774	16.927	10.090	13.238	17.927	13.418	15.446	4.294	2.989	2.521	124.722	52.654	42%	60.02	
1975	2.515	2.930	5.096	18.936	7.652	12.133	8.930	14.458	6.573	3.759	2.993	2.598	88.573	34.614	39%	42.09	
1976	3.410	5.689	21.884	15.142	9.533	10.435	16.439	10.483	5.409	3.249	2.942	2.674	107.288	52.247	49%	42.76	
1980	1.916	1.863	4.372	7.307	5.780	7.490	8.408	5.693	4.116	1.954	1.474	1.567	51.938	19.321	37%	25.70	
1981	1.585	2.400	9.624	3.594	11.796	5.157	10.173	4.612	8.013	2.190	1.527	1.396	62.068	27.414	44%	27.95	
1982	1.734	2.571	7.321	8.654	19.024	10.023	9.225	8.093	3.628	2.106	1.267	1.573	75.218	37.569	50%	30.96	
1983	2.093	3.929	6.272	10.286	9.078	10.284	6.698	6.714	2.592	1.892	1.430	1.232	62.502	29.566	47%	26.28	
1984	1.357	2.840	3.868	9.445	6.907	13.486	7.823	8.013	7.426	2.265	1.997	1.948	67.376	23.060	34%	36.74	
1985	1.930	5.173	4.897	2.658	3.517	7.690	14.130	8.158	4.207	2.051	1.795	1.861	58.067	16.245	28%	34.18	
1986	2.063	2.436	2.432	5.899	14.678	11.377	5.673	5.972	2.465	1.815	1.416	1.674	57.900	25.444	44%	25.48	
1987	1.793	6.934	3.225	3.344	7.799	9.491	5.897	3.802	1.805	1.537	1.319	1.307	48.255	21.303	44%	20.99	
MEAN	2.360	4.218	6.987	8.055	8.527	9.571	10.551	8.796	4.801	2.451	1.959	1.937	70.213	27.787	39%	33.71	
MAXIMUM	6.480	9.816	23.094	22.285	19.024	22.043	24.992	30.467	15.446	4.294	2.993	2.828	124.722	62.381	64%	72.56	
MINIMUM	1.194	1.432	2.023	2.71	2.761	2.793	2.767	3.148	1.805	1.438	1.267	1.232	39.160	12.496	18%	14.17	

TABLE 7-1

MLKW MILL CREEK NEAR WALLA WALLA, WA. 19 MAY 1998 PAGE 1 OF 3

	.00	.01	.02	.03	.04	.05	.06	.07	.08	.09
14.40	0	3	6	8	11	14	17	20	22	25
14.50	28	29	30	32	33	34	35	36	38	39
14.60	40	41	43	44	46	47	48	50	51	53
14.70	54	56	57	59	60	62	64	65	67	68
14.80	70	72	74	76	78	80	81	83	85	87
14.90	89	91	93	95	97	100	102	104	106	108
15.00	110	113	115	118	120	123	126	128	131	133
15.10	136	139	143	146	150	153	156	160	163	167
15.20	170	174	178	181	185	189	193	197	200	204
15.30	208	212	216	221	225	229	233	237	242	246
15.40	250	255	259	264	269	274	278	283	288	292
15.50	297	302	307	312	317	322	327	332	337	342
15.60	347	353	358	364	369	375	380	386	391	397
15.70	402	408	414	420	426	432	437	443	449	455
15.80	461	467	474	480	487	493	499	506	512	519
15.90	525	532	539	545	552	559	566	573	579	586
16.00	593	600	607	615	622	629	636	643	651	658
16.10	665	673	680	688	696	704	711	719	727	734
16.20	742	750	758	766	774	783	791	799	807	815
16.30	823	830	838	845	852	860	867	874	881	889
16.40	896	903	910	917	924	931	938	945	952	959

TABLE 7-1

MLKW MILL CREEK NEAR WALLA WALLA, WA. 19 MAY 1998 PAGE 2 OF 3

	.00	.01	.02	.03	.04	.05	.06	.07	.08	.09
16.50	966	973	980	988	995	1002	1009	1016	1024	1031
16.60	1038	1046	1053	1061	1068	1076	1084	1091	1099	1106
16.70	1114	1122	1130	1137	1145	1153	1161	1169	1176	1184
16.80	1192	1200	1208	1216	1224	1233	1241	1249	1257	1265
16.90	1273	1281	1290	1298	1307	1315	1323	1332	1340	1349
17.00	1357	1366	1374	1383	1391	1400	1409	1417	1426	1434
17.10	1443	1452	1461	1470	1479	1488	1497	1506	1515	1524
17.20	1533	1542	1551	1561	1570	1579	1588	1597	1607	1616
17.30	1625	1635	1644	1654	1663	1673	1683	1692	1702	1711
17.40	1721	1731	1741	1750	1760	1770	1780	1790	1799	1809
17.50	1819	1829	1839	1849	1859	1870	1880	1890	1900	1910
17.60	1920	1931	1942	1953	1964	1975	1985	1996	2007	2018
17.70	2029	2040	2051	2063	2074	2085	2096	2107	2119	2130
17.80	2141	2153	2164	2176	2187	2199	2211	2222	2234	2245
17.90	2257	2269	2281	2293	2305	2317	2328	2340	2352	2364
18.00	2376	2388	2400	2413	2425	2437	2449	2461	2474	2486
18.10	2498	2511	2523	2536	2548	2561	2574	2586	2599	2611
18.20	2624	2637	2650	2663	2676	2689	2702	2715	2728	2741
18.30	2754	2767	2780	2794	2807	2820	2833	2846	2860	2873
18.40	2886	2900	2913	2927	2941	2955	2968	2982	2996	3009

TABLE 7-2

MLKW MILL CREEK NEAR WALLA WALLA, WA. 30 June 1998 PAGE 1 OF 3

	.00	.01	.02	.03	.04	.05	.06	.07	.08	.09
1.70	0	0	0	1	1	1	1	1	2	2
1.80	2	3	4	5	6	7	7	8	9	10
1.90	11	12	14	15	17	18	19	21	22	24
2.00	25	27	29	31	33	35	36	38	40	42
2.10	44	46	49	51	53	56	58	60	62	65
2.20	67	70	73	75	78	81	84	87	89	92
2.30	95	98	101	104	107	111	114	117	120	123
2.40	126	130	133	137	140	144	147	151	154	158
2.50	161	165	168	172	176	180	183	187	191	194
2.60	198	202	206	210	214	218	221	225	229	233
2.70	237	241	246	250	254	259	263	267	271	276
2.80	280	285	289	294	298	303	308	312	317	321
2.90	326	331	336	341	346	351	355	360	365	370
3.00	375	380	385	391	396	401	406	411	417	422
3.10	427	432	438	443	449	454	459	465	470	476
3.20	481	487	492	498	504	510	515	521	527	532
3.30	538	544	550	556	562	568	574	580	586	592
3.40	598	604	611	617	623	630	636	642	648	655
3.50	661	668	674	681	687	694	700	707	713	720
3.60	726	733	740	746	753	760	767	774	780	787
3.70	794	801	808	815	822	830	837	844	851	858
3.80	865	872	880	887	894	902	909	916	923	931
3.90	938	946	953	961	968	976	983	991	998	1006

TABLE 7-2

MLKW MILL CREEK NEAR WALLA WALLA, WA. 30 June 1998 PAGE 2 OF 3

	.00	.01	.02	.03	.04	.05	.06	.07	.08	.09
4.00	1013	1021	1029	1036	1044	1052	1060	1068	1075	1083
4.10	1091	1099	1107	1115	1123	1131	1139	1147	1155	1163
4.20	1171	1179	1188	1196	1204	1213	1221	1229	1237	1246
4.30	1254	1263	1271	1280	1288	1297	1306	1314	1323	1331
4.40	1340	1349	1357	1366	1375	1384	1392	1401	1410	1418
4.50	1427	1436	1445	1454	1463	1472	1481	1490	1499	1508
4.60	1517	1526	1535	1545	1554	1563	1572	1581	1591	1600
4.70	1609	1619	1628	1638	1647	1657	1666	1676	1685	1695
4.80	1704	1714	1723	1733	1743	1753	1762	1772	1782	1791
4.90	1801	1811	1821	1831	1841	1851	1860	1870	1880	1890
5.00	1900	1910	1920	1931	1941	1951	1961	1971	1982	1992
5.10	2002	2012	2023	2033	2044	2054	2064	2075	2085	2096
5.20	2106	2117	2127	2138	2149	2160	2170	2181	2192	2202
5.30	2213	2224	2235	2246	2257	2268	2278	2289	2300	2311
5.40	2322	2333	2344	2355	2366	2378	2389	2400	2411	2422
5.50	2433	2444	2456	2467	2478	2490	2501	2512	2523	2535
5.60	2546	2558	2569	2581	2592	2604	2615	2627	2638	2650
5.70	2661	2673	2685	2696	2708	2720	2732	2744	2755	2767
5.80	2779	2791	2803	2815	2827	2839	2851	2863	2875	2887
5.90	2899	2911	2923	2936	2948	2960	2972	2984	2997	3009
6.00	3021	3033	3046	3058	3071	3083	3095	3108	3120	3133
6.10	3145	3158	3170	3183	3195	3208	3221	3233	3246	3258
6.20	3271	3284	3297	3309	3322	3335	3348	3361	3373	3386

TABLE 2-1
MILL CREEK RESERVOIR
STORAGE TABLE
18 JANUARY 1983
(ACRE-FEET)

	.0	.1	.2	.3	.4	.5	.6	.7	.8	.9
1180.00	16	17	19	20	22	23	24	26	27	29
1181.00	30	32	33	35	36	38	39	41	42	44
1182.00	45	47	48	50	51	53	55	56	58	59
1183.00	61	63	65	66	68	70	72	74	75	77
1184.00	79	81	83	85	87	90	92	94	96	98
1185.00	100	102	104	107	109	111	113	115	118	120
1186.00	122	124	127	129	132	134	136	139	141	144
1187.00	146	149	151	154	156	159	162	164	167	169
1188.00	172	175	178	181	184	187	190	193	196	199
1189.00	202	205	209	212	215	219	222	225	228	232
1190.00	235	238	242	245	249	252	255	259	262	266
1191.00	269	273	276	280	283	287	290	294	297	301
1192.00	304	308	311	315	318	322	325	329	332	336
1193.00	339	343	346	350	353	357	361	364	368	371
1194.00	375	379	382	386	389	393	397	400	404	407
1195.00	411	415	418	422	426	430	433	437	441	444
1196.00	448	452	456	460	464	468	471	475	479	483
1197.00	487	491	495	500	504	508	512	516	521	525
1198.00	529	534	538	543	547	552	556	561	565	570
1199.00	574	579	583	588	593	598	602	607	612	616
1200.00	621	626	630	635	640	645	649	654	659	663
1201.00	668	673	678	682	687	692	697	702	706	711
1202.00	716	721	726	731	736	741	745	750	755	760
1203.00	765	770	775	780	785	790	795	800	805	810
1204.00	815	820	825	830	835	841	846	851	856	861
1205.00	866	871	877	882	887	893	898	903	908	914
1206.00	919	925	930	936	941	947	953	958	964	969
1207.00	975	981	987	993	999	1005	1010	1016	1022	1028
1208.00	1034	1040	1046	1052	1058	1065	1071	1077	1083	1089
1209.00	1095	1101	1108	1114	1120	1127	1133	1139	1145	1152
1210.00	1158	1164	1171	1177	1183	1190	1196	1202	1208	1215
1211.00	1221	1227	1234	1240	1246	1253	1259	1265	1271	1278

	.0	.1	.2	.3	.4	.5	.6	.7	.8	.9
1212.00	1284	1290	1297	1303	1309	1316	1322	1328	1334	1341
1213.00	1347	1353	1360	1366	1372	1379	1385	1391	1397	1404
1214.00	1410	1416	1423	1429	1436	1442	1448	1455	1461	1468
1215.00	1474	1481	1487	1494	1501	1508	1514	1521	1528	1534
1216.00	1541	1548	1555	1562	1569	1577	1584	1591	1598	1605
1217.00	1612	1620	1627	1635	1642	1650	1657	1665	1672	1680
1218.00	1687	1695	1703	1711	1719	1727	1735	1743	1751	1759
1219.00	1767	1775	1784	1792	1801	1809	1817	1826	1834	1843
1220.00	1851	1860	1868	1877	1885	1894	1902	1911	1919	1928
1221.00	1936	1945	1953	1962	1970	1979	1988	1996	2005	2013
1222.00	2022	2031	2039	2048	2057	2066	2074	2083	2092	2100
1223.00	2109	2118	2127	2135	2144	2153	2162	2171	2179	2188
1224.00	2197	2206	2215	2224	2233	2242	2250	2259	2268	2277
1225.00	2286	2295	2304	2314	2323	2332	2341	2350	2360	2369
1226.00	2378	2387	2396	2406	2415	2424	2433	2442	2452	2461
1227.00	2474	2484	2494	2504	2514	2524	2533	2543	2553	2563
1228.00	2573	2583	2593	2604	2614	2624	2634	2644	2655	2665
1229.00	2675	2685	2696	2706	2717	2727	2737	2748	2758	2769
1230.00	2779	2790	2800	2811	2821	2832	2843	2853	2864	2874
1231.00	2885	2896	2907	2917	2928	2939	2950	2961	2971	2982
1232.00	2993	3004	3015	3026	3037	3048	3059	3070	3081	3092
1233.00	3103	3114	3125	3137	3148	3159	3170	3181	3193	3204
1234.00	3215	3227	3238	3250	3261	3273	3284	3296	3307	3319
1235.00	3330	3342	3354	3365	3377	3389	3401	3413	3424	3436
1236.00	3448	3460	3472	3484	3496	3508	3520	3532	3544	3556
1237.00	3568	3580	3593	3605	3617	3630	3642	3654	3666	3679
1238.00	3691	3704	3716	3729	3741	3754	3767	3779	3792	3804
1239.00	3817	3830	3843	3856	3869	3882	3894	3907	3920	3933
1240.00	3946	3959	3972	3986	3999	4012	4025	4038	4052	4065
1241.00	4078	4092	4105	4119	4132	4146	4159	4173	4186	4200
1242.00	4213	4227	4241	4254	4268	4282	4296	4310	4323	4337
1243.00	4351	4365	4379	4393	4407	4422	4436	4450	4464	4478
1244.00	4492	4506	4521	4535	4549	4564	4578	4592	4606	4621
1245.00	4635	4650	4664	4679	4694	4709	4723	4738	4753	4767
1246.00	4782	4797	4812	4827	4842	4857	4872	4887	4902	4917
1247.00	4932	4947	4963	4978	4994	5009	5024	5040	5055	5071
1248.00	5086	5102	5118	5133	5149	5165	5181	5197	5212	5228
1249.00	5244	5260	5276	5292	5308	5325	5341	5357	5373	5389

TABLE 2-2

RUSSELL CREEK OUTLET CANAL
 RATING TABLE
 April 5, 1979

Gage Reading	Discharge in cfs									
	0	.1	.2	.3	.4	.5	.6	.7	.8	.9
0	0	2	4	7	10	13	16	20	25	32
1	40	48	58	68	78	89	100	112	124	137
2	150	165	182	200	220	240	265	290	315	340

TABLE 4-1
 BENNINGTON LAKE
 AVERAGE REGIONAL TEMPERATURES
 (DEGREES F.)

STATION		JAN	FEB	MAR	APR	MAY	JUN	JUL	AUG	SEP	OCT	NOV	DEC	ANNUAL
RICHLAND, WA. (ELEVATION 357)	MAX	41.1	49.5	58.0	66.9	75.9	83.6	91.6	89.5	81.4	67.9	51.7	43.8	66.7
	MIN	25.9	31.3	34.6	40.8	48.3	55.1	59.8	58.6	51.1	41.3	33.6	29.3	42.5
	AVG	33.5	40.4	46.3	53.9	62.1	69.4	75.7	74.0	66.3	54.7	42.7	36.6	54.6
WALLA WALLA, WA. WSO (ELEVATION 949)	MAX	40.1	47.3	54.3	62.2	70.9	79.3	88.8	86.0	77.3	64.0	49.0	43.0	63.5
	MIN	28.4	33.9	37.3	42.4	49.3	55.8	62.2	61.2	53.6	44.5	35.9	31.4	44.7
	AVG	34.3	40.7	45.8	52.3	60.1	67.6	75.5	73.6	65.5	54.3	42.5	37.2	54.1
WALLA WALLA 13 ESE OREGON (ELEVATION 2400)	MAX	35.0	41.5	48.5	57.9	67.0	74.5	84.0	81.8	72.7	58.8	42.6	37.1	58.5
	MIN	23.9	28.0	29.4	33.5	38.8	44.2	46.3	45.9	41.5	36.1	30.2	26.7	35.4
	AVG	29.4	34.7	38.9	45.7	52.9	59.4	65.1	63.9	57.1	47.5	36.4	31.9	46.9
PENDLETON, OR. WSO AP (ELEVATION 1482)	MAX	39.4	46.9	53.4	61.4	70.6	79.6	88.9	85.9	77.1	63.7	48.7	42.5	63.2
	MIN	26.3	31.8	34.4	39.2	46.1	52.9	58.6	57.5	50.5	41.3	33.4	29.5	41.8
	AVG	32.8	39.4	43.9	50.3	58.4	66.2	73.8	71.7	63.8	52.5	41.1	36.0	52.5
MORO, OR. (ELEVATION 1868)	MAX	37.1	44.1	50.2	57.5	66.1	74.1	83.1	81.3	74.1	61.7	46.7	40.2	59.7
	MIN	23.0	28.6	30.8	35.1	41.2	48.1	53.4	52.3	45.8	37.0	30.3	26.5	37.7
	AVG	30.1	36.4	40.5	46.3	53.7	61.1	68.3	66.9	59.9	49.4	38.5	33.4	48.7

- NOTES: 1. Average Temperature Values Based on 30 Year Time Period (1951-1980).
 2. Source: Climatological Data, Oregon and Washington.

TABLE 4-2

BENNINGTON LAKE
AVERAGE REGIONAL PRECIPITATION (INCHES)

STATION	JAN	FEB	MAR	APR	MAY	JUN	JUL	AUG	SEP	OCT	NOV	DEC	ANNUA
RICHLAND, WA. (ELEVATION 357)	1.03	0.69	0.50	0.42	0.53	0.44	0.14	0.32	0.28	0.46	0.91	1.06	6.78
WALLA WALLA, WA. WSO (ELEVATION 949)	2.12	1.40	1.41	1.35	1.40	0.93	0.35	0.71	0.83	1.40	1.87	2.19	15.96
WALLA WALLA 13 ESE (ELEVATION 2400)	6.29	4.08	4.49	3.68	2.74	2.29	0.59	1.23	1.93	3.62	5.15	5.82	42.65
ELGIN, OR. (ELEVATION 2655)	3.22	2.37	2.22	1.71	1.79	1.39	0.54	0.78	1.14	1.94	3.02	3.66	23.78
PENDLETON, OR. WSO AP (ELEVATION 1482)	1.73	1.11	1.06	0.99	1.09	0.70	0.30	0.55	0.58	0.95	1.48	1.66	12.20
MORO, OR. (ELEVATION 1868)	1.83	1.04	1.01	0.73	0.85	0.65	0.24	0.42	0.47	0.77	1.63	1.74	11.38

1. Average precipitation values based on 30 year time period (1951-1980).
2. Source: Climatological Data, Oregon and Washington, 1985.

TABLE 4-3

MILL CREEK BASIN - MONTHLY PRECIPITATION
WALLA WALLA, WASHINGTON WSO (ELEVATION 949)

<u>WATER</u>													<u>WATER YEAR</u>		
<u>YEAR</u>	<u>OCT</u>	<u>NOV</u>	<u>DEC</u>	<u>JAN</u>	<u>FEB</u>	<u>MAR</u>	<u>APR</u>	<u>MAY</u>	<u>JUN</u>	<u>JUL</u>	<u>AUG</u>	<u>SEP</u>	<u>TOTAL</u>	<u>MAX</u>	<u>MIN</u>
1951	4.20	2.05	2.96	1.79	1.65	1.50	0.88	0.56	2.48	0.13	0.07	0.74	19.01	4.20	0.07
1952	2.77	0.89	1.26	1.22	1.75	1.25	1.10	0.70	2.33	0.00	0.02	0.49	13.78	2.77	0.00
1953	0.09	0.41	1.96	4.52	1.52	1.41	1.77	1.99	0.75	0.00	0.57	0.17	15.16	4.52	0.00
1954	1.32	1.97	1.94	2.21	0.60	1.30	1.13	0.81	1.34	0.13	0.96	0.61	14.32	2.21	0.13
1955	0.88	1.38	1.65	1.43	0.43	0.59	2.08	1.20	0.30	0.97	0.00	1.32	12.23	2.08	0.00
1956	3.03	3.16	2.49	3.29	1.63	0.97	0.11	2.03	.74	0.08	1.52	0.19	19.24	3.29	0.08
1957	2.08	0.53	1.82	1.76	1.10	2.94	0.56	4.19	1.05	0.00	0.15	0.97	17.15	4.19	0.00
1958	1.97	1.80	1.87	2.06	1.60	1.49	3.17	2.36	0.80	0.08	0.01	0.49	17.70	3.17	0.01
* 1959	0.44	1.39	3.35	4.00	2.25	1.50	0.85	1.53	1.19	0.05	0.99	2.41	19.95	4.00	0.05
1960	0.93	0.73	0.88	1.15	1.28	1.69	1.31	2.27	0.93	0.00	0.92	0.79	12.88	2.27	0.00
1961	1.51	2.29	0.88	0.98	3.01	2.00	1.36	1.56	0.87	0.01	0.39	0.14	15.00	3.01	0.01
1962	1.32	1.79	2.42	0.63	0.92	2.36	1.20	3.78	0.45	0.00	0.41	1.44	16.72	3.78	0.00
1963	2.99	1.76	2.40	0.93	1.60	0.78	1.86	0.67	0.20	0.49	0.66	0.92	15.26	2.99	0.20
1964	0.60	2.89	2.00	0.97	0.17	0.60	0.90	0.23	1.22	1.47	0.30	0.94	12.29	2.89	0.17
1965	0.66	3.51	4.31	3.29	0.55	0.34	1.68	0.74	0.87	0.59	2.52	0.42	19.48	4.31	0.34
1966	0.73	1.94	0.29	2.22	0.83	1.85	0.19	0.45	1.09	1.78	0.29	0.15	11.81	2.22	0.15
1967	0.87	2.72	2.60	2.11	0.36	1.99	1.66	1.46	0.31	0.00	0.00	0.70	14.78	2.72	0.00
1968	0.88	1.25	1.24	0.79	2.42	0.88	0.43	0.69	0.91	0.48	0.98	1.45	12.40	2.42	0.43
1969	1.62	2.64	3.77	4.17	1.21	0.73	2.88	1.10	0.76	0.01	0.00	0.45	19.34	4.17	0.00
1970	1.43	0.61	2.12	5.86	2.56	1.54	1.84	0.48	1.27	0.15	0.01	1.92	19.79	5.86	0.01

STATISTICS 1951-1980 (40 YEARS)

N	37	37	37	36	36	36	36	36	36	36	36	36	36
MEAN	1.55	2.06	2.22	2.02	1.64	1.67	1.34	1.42	1.02	0.42	0.66	0.92	16.78
MAXIMUM	4.20	4.24	4.31	5.86	3.19	4.17	3.26	4.19	3.01	1.78	2.94	2.41	24.33
MINIMUM	0.03	0.31	0.29	0.55	0.17	0.34	0.11	0.23	0.20	0.00	0.00	0.00	11.16

* Highest Year

** Lowest Year

Notes: 1. Water Year includes Oct, Nov, Dec of one year plus Jan through Sep of the following year (i.e., Water Year 1980 = October 1979 through September 1980).

2. Source: Climatological Data, Oregon.

TABLE 4-4

MILL CREEK BASIN - MONTHLY PRECIPITATION
WALLA WALLA 13 ESE (ELEVATION 2400)

<u>WATER</u>	<u>WATER YEAR</u>														
<u>YEAR</u>	<u>OCT</u>	<u>NOV</u>	<u>DEC</u>	<u>JAN</u>	<u>FEB</u>	<u>MAR</u>	<u>APR</u>	<u>MAY</u>	<u>JUN</u>	<u>JUL</u>	<u>AUG</u>	<u>SEP</u>	<u>TOTAL</u>	<u>MAX</u>	<u>MIN</u>
1951	7.55	6.39	6.11	6.26	4.70		0.85	1.31	4.46	0.61	0.00	1.73		7.55	0.00
1952	9.25	5.69	7.00	2.96	2.93	4.06	2.89	2.74	4.90	0.39	0.00	0.97	43.78	9.25	0.00
1953	0.37	1.03	4.48	13.32	5.18	4.73	3.44	3.39	2.05	0.00	1.49	0.41	39.89	13.32	0.00
1954	1.40	5.70	7.89	7.26	2.16	2.20	4.18	2.86	4.19	0.42	3.17	0.67	42.10	7.89	0.42
1955	1.51	2.85	4.58	2.97	2.52	5.54	4.05	1.92	0.61	2.46	0.00	2.69	31.70	5.54	0.00
1956	5.90	5.86	7.93	6.45	4.86	4.98	0.46	4.63	2.35	0.74	2.49	0.77	47.42	7.93	0.46
1957	4.58	3.06	6.66	3.01	6.40	5.53	4.42	4.36	1.30	0.03	0.36	0.80	40.51	6.66	0.03
1958	4.21	4.29	8.44	6.33	5.85	2.39	8.01	2.10	2.41	0.24	0.18	1.37	45.82	8.44	0.18
1959	3.03	8.75	8.36	8.25	3.05	5.53	3.42	3.52	1.98	0.69	1.64	6.73	54.95	8.75	0.69
1960	4.56	4.22	2.71	2.78	5.69	5.50	4.01	4.84	1.70	0.07	1.93	1.37	39.38	5.69	0.07
1961	3.26	7.98	2.83	2.95	9.85	7.21	3.73	2.79	1.64	0.09	0.78	2.12	45.23	9.85	0.09
1962	4.53	4.12	5.38	3.01	2.11	5.93	3.72	3.05	0.47	0.00	0.75	3.45	36.52	5.93	0.00
1963	4.91	4.49	2.89	2.04	4.13	4.50	4.62	1.12	1.50	0.62	0.47	1.87	33.16	4.91	0.47
1964	1.28	7.19	3.49	9.40	2.07	5.58	3.86	1.22	2.27	0.95	1.15	2.41	40.87	9.40	0.95
1965	2.26	8.15	12.93	10.19	3.473	0.72	3.49	2.57	2.76	1.33	2.93	1.71	52.47	12.93	0.72
1966	1.53	3.59	1.48	8.04	5.05	6.45	1.36	1.57	2.04	1.79	0.88	0.68	34.46	8.04	0.68
1967	3.91	5.57	4.54	8.28	1.95	4.32	3.18	2.82	1.13	0.05	0.00	0.98	36.73	8.28	0.00
1968	4.75	2.96	4.80	2.47	6.57	2.28	2.93	3.01	2.58	1.13	3.97	4.27	41.72	6.57	1.13
1969	4.73	5.91	6.58	9.79	2.20	3.03	5.51	1.92	2.86	0.00	0.00	1.50	44.03	9.79	0.00
1970	2.98	1.56	5.30	12.64	4.00	5.10	4.83	1.89	3.27	0.81	0.33	3.84	46.55	12.64	0.33

WATERWATER YEAR

<u>YEAR</u>	<u>OCT</u>	<u>NOV</u>	<u>DEC</u>	<u>JAN</u>	<u>FEB</u>	<u>MAR</u>	<u>APR</u>	<u>MAY</u>	<u>JUN</u>	<u>JUL</u>	<u>AUG</u>	<u>SEP</u>	<u>TOTAL</u>	<u>MAX</u>	<u>MIN</u>
1971	4.60	7.91	3.59	7.93	3.48	5.40	2.70	4.57	4.09	1.06	0.80	4.31	50.44	7.93	0.80
1972	5.27	5.49	7.65	4.34	6.07	5.92	4.78	2.63	1.49	0.04	0.57	2.19	46.44	7.65	0.04
* 1973	1.70	2.65	8.82	4.55	2.08	2.58	1.26	2.14	1.18	0.00	0.36	4.08	31.40	8.82	0.00
** 1974	3.24	12.83	9.51	10.29	4.72	6.07	7.16	2.41	3.98	1.12	0.00	0.00	61.33	12.83	0.00
1975	0.00	4.93	6.22	9.74	4.23	4.63	4.04	1.96	2.06	0.62	1.72	0.00	40.15	9.74	0.00
1976	4.96	7.08	3.78								2.92	0.05		7.08	0.05
1977		2.82	2.34	1.48	2.05	4.32	0.86	3.39	0.85	0.20	4.42	2.89		4.42	0.20
1978	0.91	3.58	7.75	3.43	3.74	2.11	5.85	2.97						7.75	0.91
1979		4.65						2.51	1.19	0.22	1.04	0.23		4.65	0.22
1980	4.19	3.12	4.65	5.95	3.04	4.52	3.44	3.31	2.89	0.70	1.35	1.92	39.08	5.95	0.70
1981	2.12	5.47	5.23	1.08	4.85	4.11	3.33	2.62	2.33	0.54	0.01	1.63	33.32	5.47	0.01
1982	4.68	5.97	8.16	7.81	9.16	5.53	3.57	1.93	1.54	1.70	0.99	3.05	54.09	8.16	0.99
1983				6.09	5.22	7.35	2.16	3.56	1.98	2.43	0.80	1.94		7.35	0.80
1984	1.81				4.94	7.38	2.86	4.10	4.03	0.48	1.63	1.48		7.38	0.48
1985	1.87	2.58	2.00	0.52	3.32	2.87	2.54	1.83	1.97	0.44	1.06	2.88		3.32	0.44
1986	3.34	3.73	1.23	5.87	8.38	1.72								8.38	1.81
1987	1.26	8.66	1.35	4.64	3.61	3.86	2.62	2.42	1.19	0.72	0.60	0.39	31.32	8.66	0.39
1988	0.00	2.66	5.55	6.09	1.88	6.33	3.30	2.33	1.68	0.29	0.00	1.10	31.21	6.33	0.00
1989	0.47	11.21	3.90	7.95	1.53	6.01	1.83	3.94	1.43	0.28	2.61	0.62	41.78	11.21	0.47
1990	2.43	4.46	2.95		3.54	2.68	5.21	4.19	2.15	0.89	0.52				0.52

STATISTICS 1951-1980 (40 YEARS)

N	37	38	37	36	38	37	37	38	37	37	38	37	30
MEAN	3.23	5.24	5.38	6.00	4.22	4.65	3.53	2.69	2.23	0.65	1.14	1.87	41.93
MAXIMUM	9.25	12.83	12.93	13.32	9.85	7.38	8.01	4.84	4.90	2.46	4.42	6.73	61.33
MINIMUM	0.00	1.03	1.23	0.52	1.53	0.72	0.46	1.12	0.47	0.00	0.00	0.00	25.73

* Highest Year

** Lowest Year

Notes: 1. Water Year includes Oct, Nov, Dec of one year plus Jan through Sep of the following year (*i.e.*, Water Year 1980 = October 1979 through September 1980).

2. Source: Climatological Data, Oregon.

TABLE 4-5

BENNINGTON LAKE - TOTAL MONTHLY EVAPORATION
WHITMAN MISSION, WA. (ELEVATION 623)

YEAR	APR	MAY	JUN	JUL	AUG	SEP	APR-SEP TOTAL
1963	4.22	6.65	10.47	10.49	9.63	5.93	47.39
1964	5.84	7.10	8.77	10.43	9.09	6.00	47.23
1965	5.06	6.71	9.10	10.87	9.01	5.84	46.59
1966	5.43	7.27	8.72	10.23	9.98	6.12	47.75
1967	3.67	6.21	7.77	11.86	10.97	6.80	47.28
1968	5.01	7.49	8.99	11.43	7.74	5.28	45.94
1969	4.06	6.28	9.18	10.95	9.78	5.82	46.07
1970	4.64	7.21	8.21	10.97	10.35	5.68	47.06
1971	4.75	6.92	6.71	10.73	9.95	5.02	44.08
1972	4.81	6.63	8.46	10.14	8.86	5.99	44.89
1973	5.57	8.07	9.05	11.83	10.67	5.65	50.84
1974	4.31	7.10	9.61	9.90	9.97	6.68	47.57
1975	4.36	6.79	7.63	9.93	9.41	5.90	44.02
1976	3.74	7.05	7.86	10.25	7.38	6.10	42.38
1977	6.59	6.51	10.23	11.83	10.17	4.64	49.97
1978	4.11	6.84	9.91	9.84	8.38	4.57	43.65
* 1979	5.04	7.81	10.33	12.63	9.10	6.40	51.31
1980	5.40	5.49	7.31	10.31	9.33	5.46	43.30
1981	5.00	5.64	6.56	10.97	9.43	6.16	43.76
1982	4.78	6.73	7.79	9.90	8.97	4.48	42.65
1983	4.30	6.42	7.61	8.98	8.09	4.91	40.31
** 1984	4.27	5.30	6.40	9.69	8.73	4.82	39.21
1985	4.53	6.83	8.97	11.61	7.58	4.12	43.64
1986	4.68	6.50	9.30	9.55	9.49	4.84	44.36
1987							
1988	4.81	6.81	7.75	10.85	10.29	6.13	46.64
1989	4.77	6.00	9.00	10.13	8.14	5.58	43.62
1990	5.14	5.85	7.84	10.30	8.19		
STATISTICS 1963 - 1985 (33 Years)							
N	27	27	27	27	27	27	27
MEAN	4.77	6.67	8.50	10.69	9.24	5.58	45.52
MAXIMUM	6.59	8.07	10.47	12.63	10.97	6.80	51.31
MINIMUM	3.67	5.30	6.40	8.98	7.38	4.12	39.21
* Highest Year							
** Lowest Year							

Source: Climatological Data, Washington.

TABLE 4-6

MILL CREEK AT WALLA WALLA, WASHINGTON
Total Monthly Runoff Volume In 1,000 Acre-Feet

YEAR	OCT	NOV	DEC	JAN	FEB	MAR	APR	MAY	JUN	JUL	AUG	SEP	TOTAL	NOV- FEB	%	MAR- JUN	%
1942	0.375	2.588	5.586	5.008	6.567	6.020	3.273	4.384	3.858	0.528	0.317	0.438	38.942	19.749	51%	17.535	45%
1943	0.643	3.667	11.709	7.135	11.615	6.843	14.236	7.936	2.017	0.184	0.290	0.196	66.471	34.126	51%	31.032	47%
1944	1.099	1.410	2.146	0.974	3.582	8.585	9.346	2.436	0.403	0.105	0.139	0.123	30.348	8.112	27%	20.770	68%
1945	0.367	0.319	0.280	3.917	10.449	9.069	11.254	6.942	2.200	0.171	0.103	0.228	45.299	14.965	33%	29.465	65%
1946	0.230	2.668	9.660	16.798	10.163	15.017	6.458	5.096	1.595	0.349	0.300	0.325	68.659	39.289	57%	28.166	41%
1947	0.407	5.270	8.039	7.972	0.887	0.179	0.547	0.904	0.371	0.137	0.252	0.472	25.437	22.168	87%	2.001	8%
1948	1.029	8.727	6.901	8.882	6.865	7.101	14.722	21.180	5.223	0.339	0.333	0.214	81.516	31.375	38%	48.226	59%
1949	0.214	1.160	2.856	3.243	11.447	19.625	14.769	9.437	1.214	0.260	0.278	0.274	64.777	18.706	29%	45.045	70%
1950	0.403	0.655	2.009	5.346	18.298	20.714	11.324	6.615	7.006	0.226	0.077	0.103	72.776	26.308	36%	45.659	63%
1951	0.825	8.132	9.525	12.990	18.460	10.280	7.976	4.393	5.227	0.278	0.284	0.173	78.543	49.107	63%	27.876	35%
1952	15.895	2.771	6.863	3.602	10.760	7.065	16.421	5.962	0.692	0.591	0.054	0.093	60.769	23.996	39%	30.140	50%
1953	0.165	0.194	0.276	16.045	12.609	12.794	9.479	7.539	4.013	0.438	0.317	0.345	64.214	29.124	45%	33.825	53%
1954	0.339	0.662	8.712	7.472	8.474	3.713	8.493	2.009	6.748	0.252	0.230	0.200	47.304	25.320	54%	20.963	44%
1955	0.113	0.391	0.768	1.563	1.662	2.793	10.628	9.856	1.537	0.363	0.121	0.177	29.972	4.384	15%	24.814	83%
1956	0.192	3.035	15.204	11.088	4.804	14.418	11.480	6.605	1.377	0.381	0.040	0.010	68.634	34.131	50%	33.880	49%
1957	0.294	0.478	6.778	2.073	9.396	14.969	11.554	7.674	0.504	0.133	0.119	0.115	54.087	18.725	35%	34.701	64%
1958	0.052	0.428	7.295	10.398	16.378	4.614	17.451	7.440	1.507	0.246	0.123	0.127	66.059	34.499	52%	31.012	47%
1959	0.024	3.777	12.623	17.009	8.416	11.072	9.945	5.976	1.022	0.061	0.065	0.474	70.464	41.825	59%	28.015	40%
1960	1.335	3.336	2.596	2.743	8.571	9.455	8.795	5.893	0.754	0.141	0.208	0.129	43.956	17.246	39%	24.897	57%
1961	0.087	3.009	2.501	3.142	16.451	18.885	7.755	5.994	0.807	0.190	0.232	0.214	59.267	25.103	42%	33.441	56%
1962	0.135	1.031	6.212	5.516	2.705	10.584	10.677	4.395	0.474	0.093	0.083	0.071	41.976	15.464	37%	26.130	62%
1963	1.722	3.193	5.927	2.440	8.819	5.104	7.601	1.591	0.000	0.016	0.004	0.002	36.419	20.379	56%	14.296	39%
1964	0.000	0.561	2.017	6.589	4.655	6.980	12.056	7.313	2.023	0.093	0.054	0.038	42.379	13.822	33%	28.372	67%
1965	0.032	3.717	26.611	19.462	12.756	5.849	8.803	2.418	1.216	0.115	0.087	0.034	81.100	62.546	77%	18.286	23%
1966	0.002	0.058	0.583	5.994	4.830	15.354	9.299	1.531	0.097	0.071	0.091	0.048	37.958	11.465	30%	26.281	69%
1967	0.008	0.879	5.201	12.855	5.058	6.127	5.992	7.960	0.242	0.073	0.133	0.107	44.635	23.993	54%	20.321	46%
1968	0.044	0.010	3.842	4.520	12.425	2.596	2.906	0.030	0.052	0.058	0.061	0.028	26.572	20.797	78%	5.584	21%

YEAR	OCT	NOV	DEC	JAN	FEB	MAR	APR	MAY	JUN	JUL	AUG	SEP	TOTAL	NOV- FEB	%	MAR- JUN	%
1969	0.532	4.812	7.619	18.595	6.500	11.235	17.814	8.400	0.504	0.004	0.000	0.000	76.015	37.526	49%	37.953	50%
1970	0.008	0.002	1.339	22.691	12.304	11.461	8.386	6.187	1.571	0.044	0.030	0.089	64.112	36.336	57%	27.605	43%
1971	0.371	5.802	5.907	16.997	8.146	10.152	8.523	5.835	4.556	0.401	0.077	0.672	67.439	36.852	55%	29.066	43%
1972	0.274	3.013	10.471	10.146	15.110	24.070	10.344	7.732	1.051	0.115	0.050	0.006	82.382	38.740	47%	43.197	52%
1973	0.000	0.155	5.980	8.521	4.334	6.002	1.966	0.079	0.000	0.000	0.000	0.026	27.063	18.990	70%	8.047	30%
1974	0.012	9.055	23.086	22.892	13.813	15.368	22.687	13.448	10.645	0.813	0.000	0.000	131.819	68.846	52%	62.148	47%
1975	0.000	0.476	4.560	20.202	8.206	12.437	8.116	11.231	2.898	0.494	0.012	0.000	68.632	33.444	49%	34.682	51%
1976	0.135	2.051	21.102	21.273	11.350	12.472	19.303	8.212	2.162	0.020	0.111	0.034	98.225	55.776	57%	42.149	43%
1977	0.248	0.559	0.809	1.906	0.661	4.413	3.711	0.494	0.000	0.010	0.105	0.020	12.936	3.935	30%	8.618	67%
1978	0.034	2.551	14.160	10.536	9.013	6.825	7.553	4.336	0.000	0.048	0.054	0.014	55.124	36.260	66%	18.714	34%
1979	0.000	0.272	4.727	2.690	12.851	12.121	13.289	8.511	0.317	0.077	0.032	0.016	54.903	20.540	37%	34.238	62%
1980	0.119	0.296	3.376	10.015	7.791	9.509	7.579	2.386	1.660	0.000	0.000	0.000	42.731	21.478	50%	21.134	49%
1981	0.042	1.446	10.673	3.410	16.477	7.523	14.329	4.205	8.795	1.127	0.000	0.000	68.027	32.006	47%	34.852	51%
1982	0.214	2.079	10.150	14.184	27.170	15.739	12.425	7.333	1.882	0.268	0.002	0.133	91.579	53.583	59%	37.379	41%
1983	0.625	2.751	7.067	12.113	12.224	13.676	7.599	5.421	0.339	0.026	0.000	0.056	61.897	34.155	55%	27.035	44%
1984	0.030	2.807	6.460	13.484	10.062	20.402	6.657	5.958	9.622	0.829	0.186	0.157	76.654	32.813	43%	42.639	56%
1985	0.260	5.933	7.398	3.808	5.988	9.346	15.646	6.803	1.974	0.012	0.006	0.000	57.174	23.128	40%	33.769	59%
1986	0.748	2.460	3.068	8.593	20.053	14.882	4.721	4.221	0.956	0.335	0.127	0.353	60.517	34.174	56%	24.780	41%
1987	0.569	5.869	2.327	3.491	10.048	10.263	4.532	1.502	0.040	0.004	0.095	0.000	38.740	21.735	56%	16.336	42%
MEAN	0.440	2.489	7.022	9.355	9.983	10.515	9.966	5.909	2.199	0.229	0.115	0.138	58.359	28.849	49%	28.589	49%
MAXIMUM	5.895	9.055	26.611	22.892	27.170	24.070	22.687	21.180	10.645	1.127	0.333	0.672	131.819	68.846	52%	62.148	47%
MINIMUM	0.000	0.002	0.276	0.974	0.661	0.179	0.547	0.030	0.000	0.000	0.000	0.000	12.936	3.935	30%	2.001	15%

TABLE 4-7

MILL CREEK NEAR WALLA WALLA, WASHINGTON
Total Monthly Runoff Volume In 1,000 Acre-Feet

YEAR	OCT	NOV	DEC	JAN	FEB	MAR	APR	MAY	JUN	JUL	AUG	SEP	TOTAL	NOV- FEB	%	MAR- JUN	%
1914	2.890	3.925	2.660	7.355	7.805	11.173	7.968	4.943	2.995	2.184	2.003	2.166	58.067	21.745	37%	27.07	
1915	2.337	2.981	2.079	2.493	5.625	7.625	7.726	9.118	2.944	1.833	1.498	1.436	47.693	13.178	28%	27.41	
1916	1.743	4.292	7.234	3.987	11.590	19.377	11.746	10.314	5.861	3.128	1.888	1.734	82.894	27.103	33%	47.29	
1917	1.775	2.303	4.463	4.996	6.438	4.391	24.992	30.467	12.718	3.753	1.926	1.835	100.058	18.201	18%	72.56	
1940	1.194	1.432	2.307	3.068	11.425	10.628	9.789	4.639	1.987	1.706	1.642	1.720	51.537	18.232	35%	27.04	
1941	1.769	3.394	5.348	4.925	2.761	2.793	2.767	5.131	4.743	2.204	1.619	1.708	39.160	16.427	42%	15.43	
1942	2.204	5.125	6.863	3.318	5.478	6.228	6.528	7.131	6.272	2.731	1.513	1.343	54.735	20.785	38%	26.15	
1943	1.660	5.351	10.653	6.438	9.324	8.404	14.424	9.812	5.586	2.565	1.785	1.603	77.606	31.768	41%	38.22	
1944	2.491	2.876	3.451	2.071	4.098	7.997	9.269	5.304	2.773	1.642	1.515	1.688	45.176	12.496	28%	25.34	
1945	1.646	2.001	2.116	6.306	7.563	8.501	11.205	10.163	4.990	2.009	1.712	1.894	60.108	17.986	30%	34.86	
1946	1.930	6.073	8.946	10.209	7.942	12.411	11.330	9.402	5.066	3.285	2.099	1.948	80.639	33.170	41%	38.20	
1947	3.003	8.144	14.735	9.806	6.306	9.065	10.699	5.213	3.039	2.239	1.872	2.019	76.141	38.992	51%	28.01	
1948	3.733	9.816	8.987	9.689	11.211	6.754	12.171	18.954	7.071	3.312	2.567	2.448	96.713	39.704	41%	44.95	
1949	2.384	4.830	6.484	3.610	8.299	15.959	16.872	13.002	4.471	2.870	2.380	2.166	83.327	23.223	28%	50.30	
1950	2.509	3.065	4.237	5.578	14.846	19.512	13.466	13.873	9.729	3.701	2.866	2.642	96.023	27.725	29%	56.57	
1951	3.568	8.596	10.693	10.334	13.410	9.197	9.505	6.423	6.518	2.787	2.547	2.374	85.953	43.034	50%	31.64	
1952	6.480	6.333	7.845	4.945	10.074	8.600	16.463	10.035	4.562	3.804	2.348	2.194	83.684	29.197	35%	39.66	
1953	2.333	2.120	2.390	13.859	10.239	11.090	10.526	9.015	5.586	2.836	2.358	2.176	74.528	28.608	38%	36.21	
1954	2.303	3.037	9.449	8.364	8.208	5.768	9.804	5.431	7.297	2.553	2.323	2.178	66.715	29.058	44%	28.30	
1955	2.368	2.523	2.785	3.548	3.902	4.953	10.138	10.854	5.312	2.390	1.801	1.791	52.364	12.758	24%	31.25	
1956	2.164	4.671	12.163	9.035	4.622	10.701	13.214	9.572	3.499	2.186	1.952	1.807	75.585	30.490	40%	36.98	
1957	2.335	2.963	7.815	2.672	7.168	11.566	11.806	9.562	3.013	2.382	2.148	2.033	65.463	20.618	31%	35.94	
1958	2.323	3.158	8.126	9.071	15.045	5.879	16.043	11.231	3.336	2.293	2.055	2.025	80.584	35.400	44%	36.48	
1959	2.192	6.127	13.648	15.761	7.502	9.219	9.963	8.035	4.304	2.551	2.202	2.828	84.332	43.038	51%	31.52	
1960	4.294	6.847	4.594	4.163	8.107	9.368	9.088	7.567	3.719	2.112	2.503	2.426	64.789	23.711	37%	29.74	
1961	2.489	4.931	4.110	4.544	14.333	15.451	9.251	8.305	3.205	2.150	1.952	2.097	72.818	27.918	38%	36.21	
1962	2.130	3.061	6.363	6.690	4.316	9.138	11.129	7.075	3.197	1.932	1.726	1.841	58.599	20.430	35%	30.54	

YEAR	OCT	NOV	DEC	JAN	FEB	MAR	APR	MAY	JUN	JUL	AUG	SEP	TOTAL	NOV- FEB	%	MAR- JUN	%
1963	3.523	4.776	6.300	3.267	7.414	6.165	8.232	4.588	2.164	2.017	1.813	1.734	51.992	21.757	42%	21.14	
1964	1.753	3.598	4.380	6.385	5.022	6.877	12.264	11.276	4.866	2.144	1.847	1.775	62.187	19.385	31%	35.28	
1965	1.864	5.008	23.094	22.285	11.994	5.889	10.689	6.026	4.090	2.257	2.021	1.978	97.195	62.381	64%	26.69	
1966	1.954	2.023	2.023	5.088	4.227	11.629	9.769	5.786	2.551	1.985	1.531	1.450	50.016	13.361	27%	29.73	
1967	1.829	2.704	5.738	10.915	4.717	6.105	6.103	8.759	3.098	1.559	1.436	1.619	54.582	24.074	44%	24.06	
1968	1.942	2.075	5.223	4.883	11.532	4.169	4.862	3.148	1.993	1.438	1.535	1.787	44.587	23.713	53%	14.17	
1969	2.886	5.175	6.085	15.390	4.429	9.112	13.875	9.927	3.318	2.085	1.624	1.638	75.546	31.079	41%	36.23	
1970	1.870	1.680	3.398	17.173	9.503	9.221	7.823	8.537	4.171	2.285	1.984	1.928	69.573	31.754	46%	29.75	
1971	2.503	6.559	5.502	13.573	8.289	9.065	8.868	8.400	6.444	2.551	1.791	2.021	75.567	33.924	45%	32.77	
1972	1.978	4.520	7.640	8.963	13.184	22.043	10.725	10.768	4.497	3.237	2.471	2.575	92.602	34.309	37%	48.03	
1973	2.670	2.944	6.674	7.750	4.025	6.157	4.590	3.779	2.573	2.297	1.982	1.950	47.388	21.392	45%	17.09	
1974	2.235	8.862	16.774	16.927	10.090	13.238	17.927	13.418	15.446	4.294	2.989	2.521	124.722	52.654	42%	60.02	
1975	2.515	2.930	5.096	18.936	7.652	12.133	8.930	14.458	6.573	3.759	2.993	2.598	88.573	34.614	39%	42.09	
1976	3.410	5.689	21.884	15.142	9.533	10.435	16.439	10.483	5.409	3.249	2.942	2.674	107.288	52.247	49%	42.76	
1980	1.916	1.863	4.372	7.307	5.780	7.490	8.408	5.693	4.116	1.954	1.474	1.567	51.938	19.321	37%	25.70	
1981	1.585	2.400	9.624	3.594	11.796	5.157	10.173	4.612	8.013	2.190	1.527	1.396	62.068	27.414	44%	27.95	
1982	1.734	2.571	7.321	8.654	19.024	10.023	9.225	8.093	3.628	2.106	1.267	1.573	75.218	37.569	50%	30.96	
1983	2.093	3.929	6.272	10.286	9.078	10.284	6.698	6.714	2.592	1.892	1.430	1.232	62.502	29.566	47%	26.28	
1984	1.357	2.840	3.868	9.445	6.907	13.486	7.823	8.013	7.426	2.265	1.997	1.948	67.376	23.060	34%	36.74	
1985	1.930	5.173	4.897	2.658	3.517	7.690	14.130	8.158	4.207	2.051	1.795	1.861	58.067	16.245	28%	34.18	
1986	2.063	2.436	2.432	5.899	14.678	11.377	5.673	5.972	2.465	1.815	1.416	1.674	57.900	25.444	44%	25.48	
1987	1.793	6.934	3.225	3.344	7.799	9.491	5.897	3.802	1.805	1.537	1.319	1.307	48.255	21.303	44%	20.99	
MEAN	2.360	4.218	6.987	8.055	8.527	9.571	10.551	8.796	4.801	2.451	1.959	1.937	70.213	27.787	39%	33.71	
MAXIMUM	6.480	9.816	23.094	22.285	19.024	22.043	24.992	30.467	15.446	4.294	2.993	2.828	124.722	62.381	64%	72.56	
MINIMUM	1.194	1.432	2.023	2.71	2.761	2.793	2.767	3.148	1.805	1.438	1.267	1.232	39.160	12.496	18%	14.17	

TABLE 7-1

MLKW MILL CREEK NEAR WALLA WALLA, WA. 19 MAY 1998 PAGE 1 OF 3

	.00	.01	.02	.03	.04	.05	.06	.07	.08	.09
14.40	0	3	6	8	11	14	17	20	22	25
14.50	28	29	30	32	33	34	35	36	38	39
14.60	40	41	43	44	46	47	48	50	51	53
14.70	54	56	57	59	60	62	64	65	67	68
14.80	70	72	74	76	78	80	81	83	85	87
14.90	89	91	93	95	97	100	102	104	106	108
15.00	110	113	115	118	120	123	126	128	131	133
15.10	136	139	143	146	150	153	156	160	163	167
15.20	170	174	178	181	185	189	193	197	200	204
15.30	208	212	216	221	225	229	233	237	242	246
15.40	250	255	259	264	269	274	278	283	288	292
15.50	297	302	307	312	317	322	327	332	337	342
15.60	347	353	358	364	369	375	380	386	391	397
15.70	402	408	414	420	426	432	437	443	449	455
15.80	461	467	474	480	487	493	499	506	512	519
15.90	525	532	539	545	552	559	566	573	579	586
16.00	593	600	607	615	622	629	636	643	651	658
16.10	665	673	680	688	696	704	711	719	727	734
16.20	742	750	758	766	774	783	791	799	807	815
16.30	823	830	838	845	852	860	867	874	881	889
16.40	896	903	910	917	924	931	938	945	952	959

TABLE 7-1

MLKW MILL CREEK NEAR WALLA WALLA, WA. 19 MAY 1998 PAGE 2 OF 3

	.00	.01	.02	.03	.04	.05	.06	.07	.08	.09
16.50	966	973	980	988	995	1002	1009	1016	1024	1031
16.60	1038	1046	1053	1061	1068	1076	1084	1091	1099	1106
16.70	1114	1122	1130	1137	1145	1153	1161	1169	1176	1184
16.80	1192	1200	1208	1216	1224	1233	1241	1249	1257	1265
16.90	1273	1281	1290	1298	1307	1315	1323	1332	1340	1349
17.00	1357	1366	1374	1383	1391	1400	1409	1417	1426	1434
17.10	1443	1452	1461	1470	1479	1488	1497	1506	1515	1524
17.20	1533	1542	1551	1561	1570	1579	1588	1597	1607	1616
17.30	1625	1635	1644	1654	1663	1673	1683	1692	1702	1711
17.40	1721	1731	1741	1750	1760	1770	1780	1790	1799	1809
17.50	1819	1829	1839	1849	1859	1870	1880	1890	1900	1910
17.60	1920	1931	1942	1953	1964	1975	1985	1996	2007	2018
17.70	2029	2040	2051	2063	2074	2085	2096	2107	2119	2130
17.80	2141	2153	2164	2176	2187	2199	2211	2222	2234	2245
17.90	2257	2269	2281	2293	2305	2317	2328	2340	2352	2364
18.00	2376	2388	2400	2413	2425	2437	2449	2461	2474	2486
18.10	2498	2511	2523	2536	2548	2561	2574	2586	2599	2611
18.20	2624	2637	2650	2663	2676	2689	2702	2715	2728	2741
18.30	2754	2767	2780	2794	2807	2820	2833	2846	2860	2873
18.40	2886	2900	2913	2927	2941	2955	2968	2982	2996	3009

TABLE 7-2

MLKW MILL CREEK NEAR WALLA WALLA, WA. 30 June 1998 PAGE 1 OF 3

	.00	.01	.02	.03	.04	.05	.06	.07	.08	.09
1.70	0	0	0	1	1	1	1	1	2	2
1.80	2	3	4	5	6	7	7	8	9	10
1.90	11	12	14	15	17	18	19	21	22	24
2.00	25	27	29	31	33	35	36	38	40	42
2.10	44	46	49	51	53	56	58	60	62	65
2.20	67	70	73	75	78	81	84	87	89	92
2.30	95	98	101	104	107	111	114	117	120	123
2.40	126	130	133	137	140	144	147	151	154	158
2.50	161	165	168	172	176	180	183	187	191	194
2.60	198	202	206	210	214	218	221	225	229	233
2.70	237	241	246	250	254	259	263	267	271	276
2.80	280	285	289	294	298	303	308	312	317	321
2.90	326	331	336	341	346	351	355	360	365	370
3.00	375	380	385	391	396	401	406	411	417	422
3.10	427	432	438	443	449	454	459	465	470	476
3.20	481	487	492	498	504	510	515	521	527	532
3.30	538	544	550	556	562	568	574	580	586	592
3.40	598	604	611	617	623	630	636	642	648	655
3.50	661	668	674	681	687	694	700	707	713	720
3.60	726	733	740	746	753	760	767	774	780	787
3.70	794	801	808	815	822	830	837	844	851	858
3.80	865	872	880	887	894	902	909	916	923	931
3.90	938	946	953	961	968	976	983	991	998	1006

TABLE 7-2

MLKW MILL CREEK NEAR WALLA WALLA, WA. 30 June 1998 PAGE 2 OF 3

	.00	.01	.02	.03	.04	.05	.06	.07	.08	.09
4.00	1013	1021	1029	1036	1044	1052	1060	1068	1075	1083
4.10	1091	1099	1107	1115	1123	1131	1139	1147	1155	1163
4.20	1171	1179	1188	1196	1204	1213	1221	1229	1237	1246
4.30	1254	1263	1271	1280	1288	1297	1306	1314	1323	1331
4.40	1340	1349	1357	1366	1375	1384	1392	1401	1410	1418
4.50	1427	1436	1445	1454	1463	1472	1481	1490	1499	1508
4.60	1517	1526	1535	1545	1554	1563	1572	1581	1591	1600
4.70	1609	1619	1628	1638	1647	1657	1666	1676	1685	1695
4.80	1704	1714	1723	1733	1743	1753	1762	1772	1782	1791
4.90	1801	1811	1821	1831	1841	1851	1860	1870	1880	1890
5.00	1900	1910	1920	1931	1941	1951	1961	1971	1982	1992
5.10	2002	2012	2023	2033	2044	2054	2064	2075	2085	2096
5.20	2106	2117	2127	2138	2149	2160	2170	2181	2192	2202
5.30	2213	2224	2235	2246	2257	2268	2278	2289	2300	2311
5.40	2322	2333	2344	2355	2366	2378	2389	2400	2411	2422
5.50	2433	2444	2456	2467	2478	2490	2501	2512	2523	2535
5.60	2546	2558	2569	2581	2592	2604	2615	2627	2638	2650
5.70	2661	2673	2685	2696	2708	2720	2732	2744	2755	2767
5.80	2779	2791	2803	2815	2827	2839	2851	2863	2875	2887
5.90	2899	2911	2923	2936	2948	2960	2972	2984	2997	3009
6.00	3021	3033	3046	3058	3071	3083	3095	3108	3120	3133
6.10	3145	3158	3170	3183	3195	3208	3221	3233	3246	3258
6.20	3271	3284	3297	3309	3322	3335	3348	3361	3373	3386

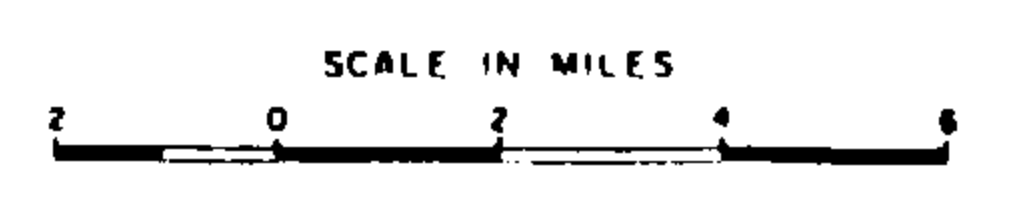
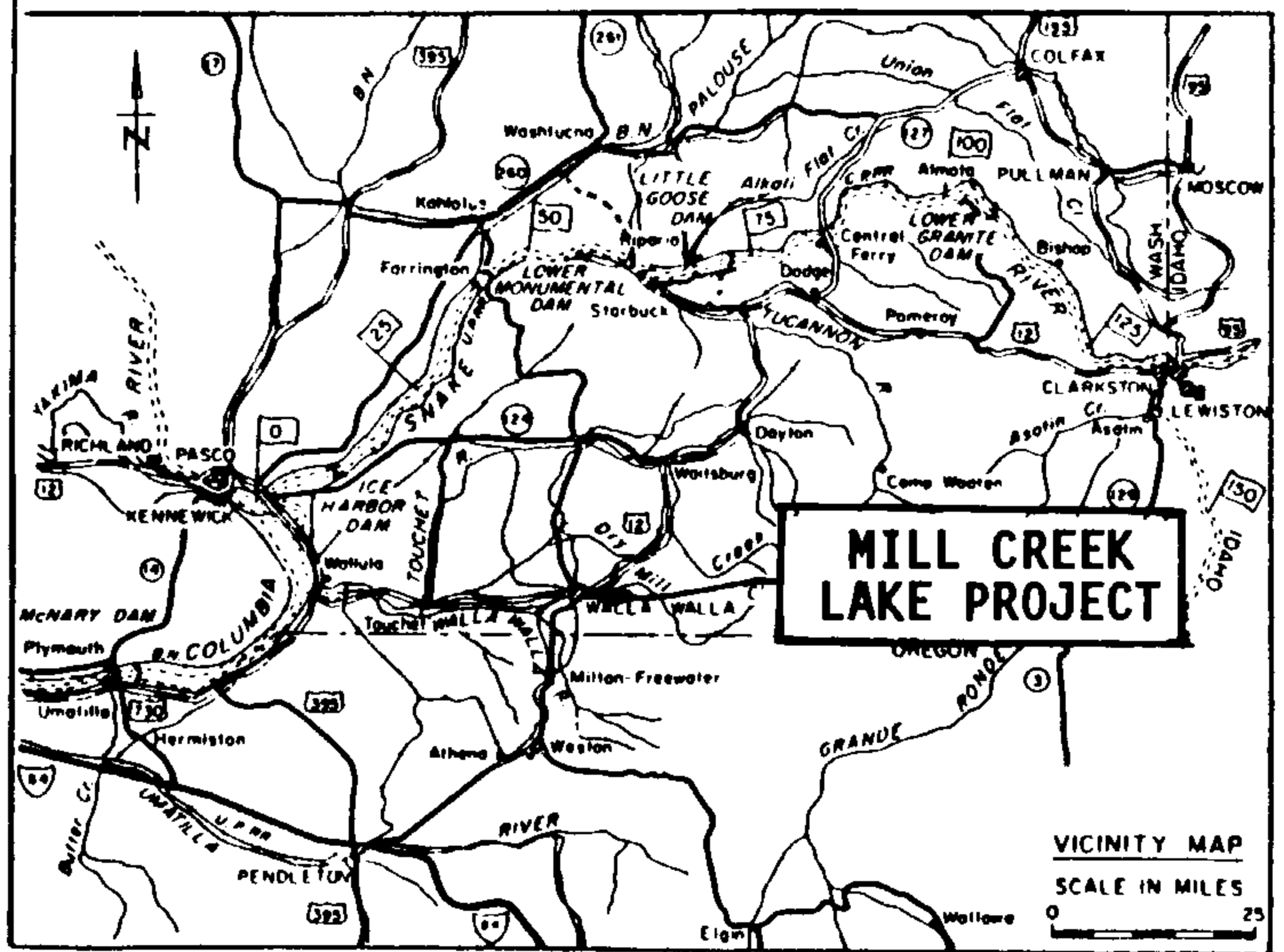
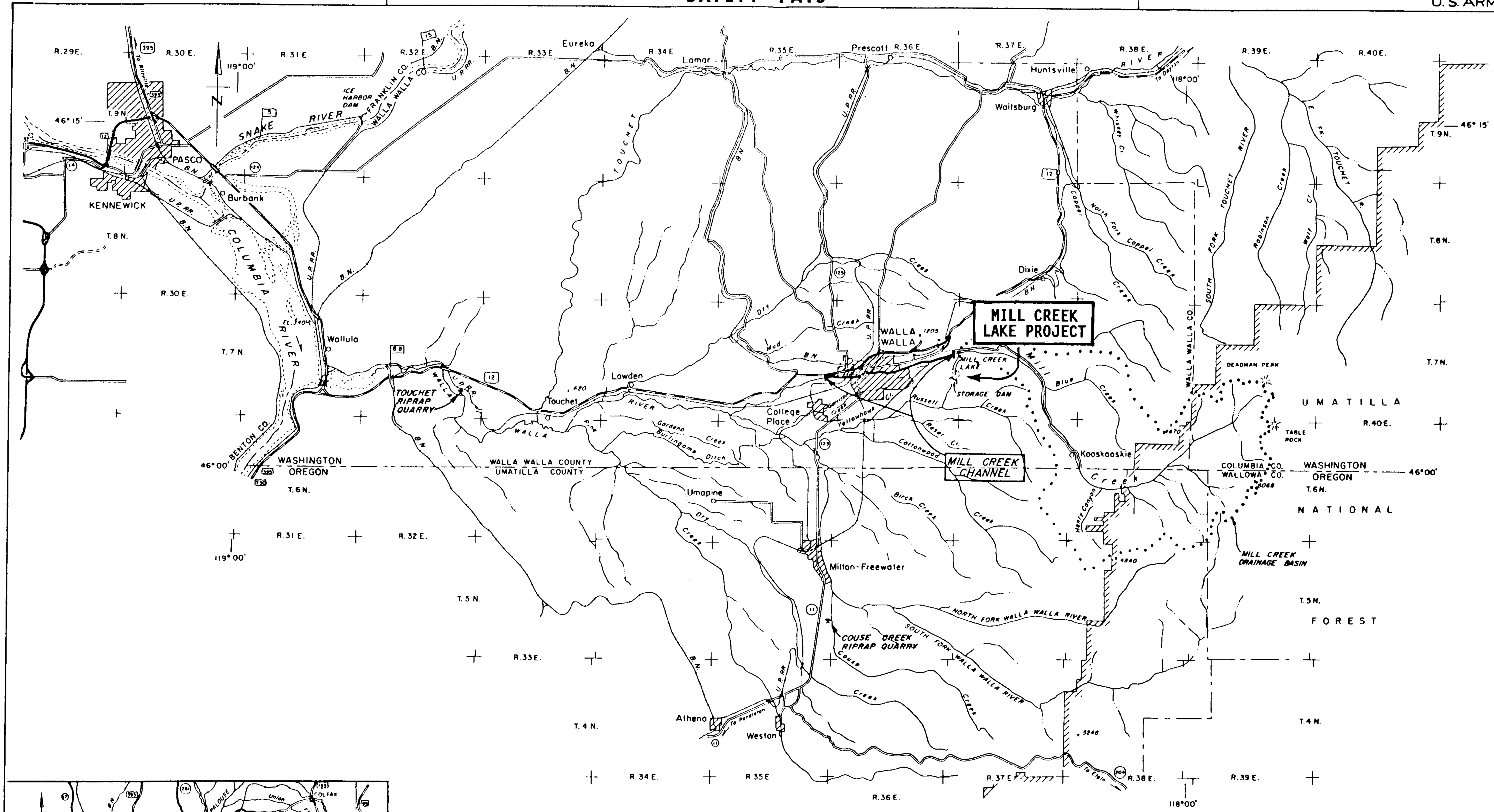

REVISION	DATE	DESCRIPTION	BY
<p align="center">U. S. ARMY ENGINEER DISTRICT WALLA WALLA, WASHINGTON</p> <p align="center">MILL CREEK FLOOD CONTROL PROJECT WALLA WALLA, WASHINGTON</p> <p align="center">MILL CREEK LAKE PROJECT LOCATION MAP</p>			
DESIGNED BY	E. Rogers		
DRAWN BY	J. D. G. Dugan		
CHECKED BY	R. W. W. W. W.		
SUPERVISOR	J. J. J. J.		
ENGINEER	J. J. J. J.		
CHIEF ENGINEERING DIVISION	J. J. J. J.		
DATE	12/21/51		
SCALE	AS SHOWN		
FILE NO.	MC-05-15/1		

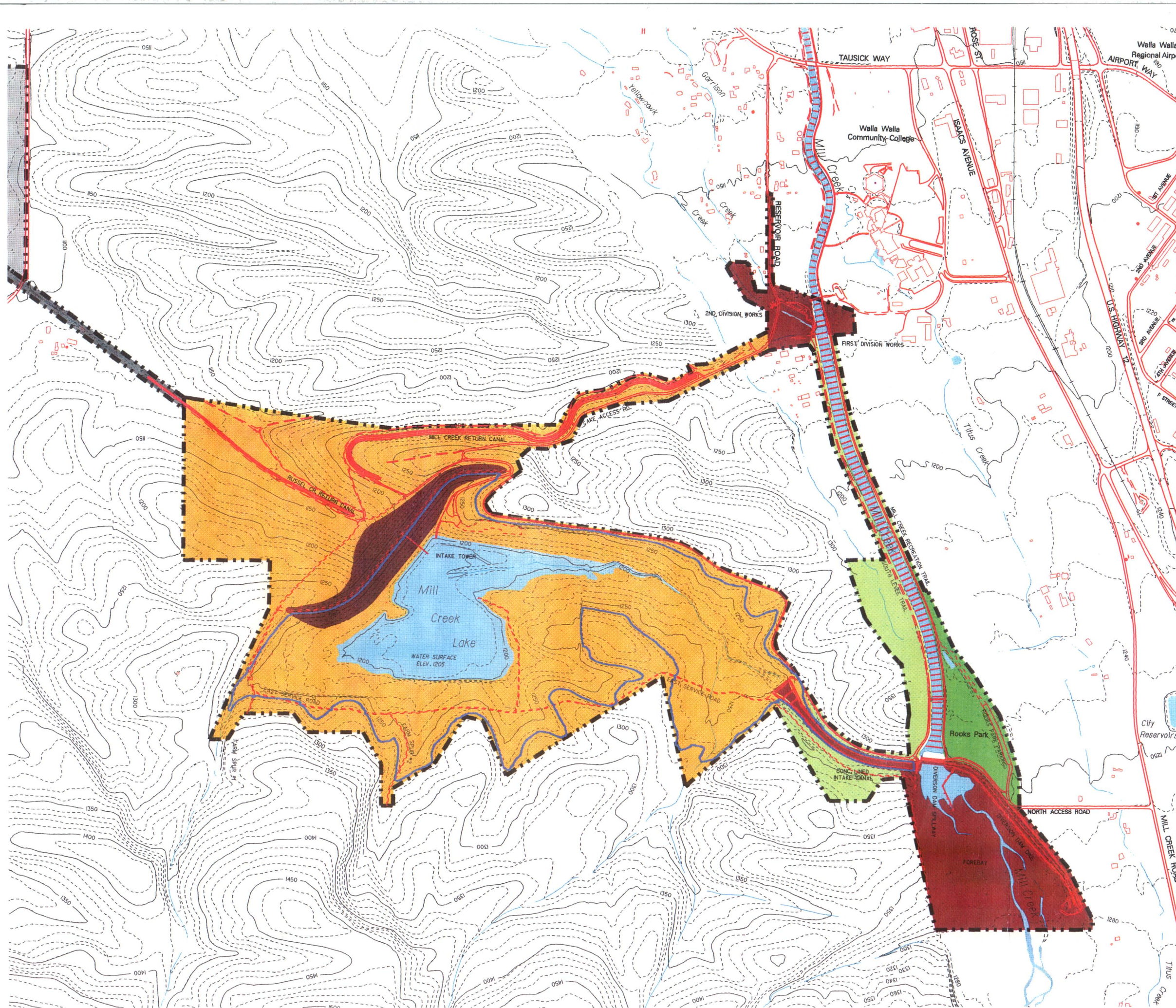

- MILL CREEK LAKE**
- CONSERVATION POOL 1205
 - MAXIMUM FLOOD CONTROL 1265
 - PROJECT OPERATIONS**
 - RECREATION**
 - MULTIPLE RESOURCE MANAGEMENT**
 - RECREATION - LOW DENSITY
 - WILDLIFE MANAGEMENT GENERAL
 - EASEMENT LANDS**
 - CANAL OUTLET RIGHT /WAY EASEMENT
 - FLOWAGE EASEMENT

LAND USE APPROVED 1982
 Sources: USACE, Walla Walla District, Engineering Division, Geotechnical Branch, Surveys and Mapping Section
 Aerial Photo Flight - W88-1 18 Feb Stereo Compilation - John Staudenmayer GIS Conversion - Bob Meyer

1/8 MILE 0 500 FEET 1000 1500 ACRES 4

GEOGRAPHIC INFORMATION SYSTEMS
 Corps of Engineers
 Walla Walla District

Mill Creek Lake

LAND USE

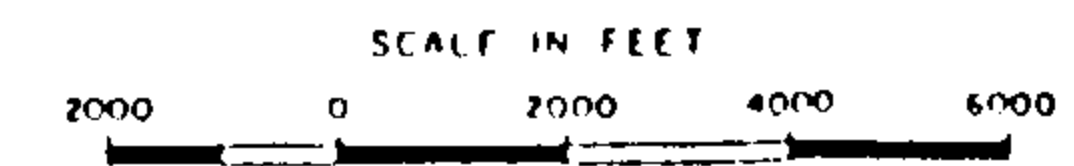
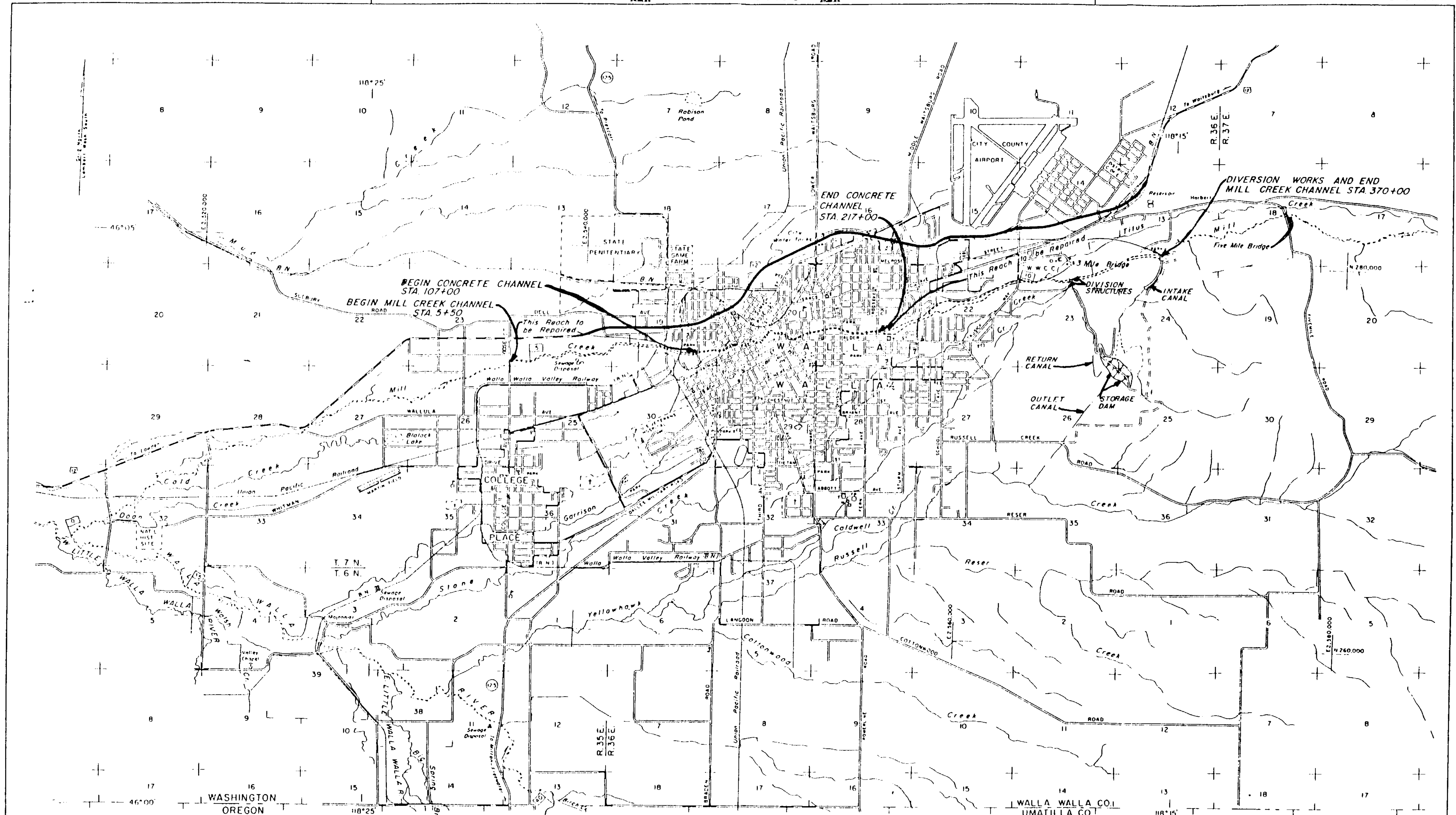

REVISION	DATE	DESCRIPTION	BY
U. S. ARMY ENGINEER DISTRICT WALLA WALLA, WASHINGTON MILL CREEK FLOOD CONTROL PROJECT WALLA WALLA, WASHINGTON MILL CREEK CHANNEL GENERAL PLAN			
DESIGNED	E. Rogers		
DRAWN	S. Graham		
CHECKED	R. Miller		
SUBMITTED BY <i>[Signature]</i> CHIEF, FOUNDATIONS AND MATERIALS BRANCH		DATE 12.02.08	
SCALE AS SHOWN		INV. NO.	
SHEET		FILE NO. MC-05-15/2	

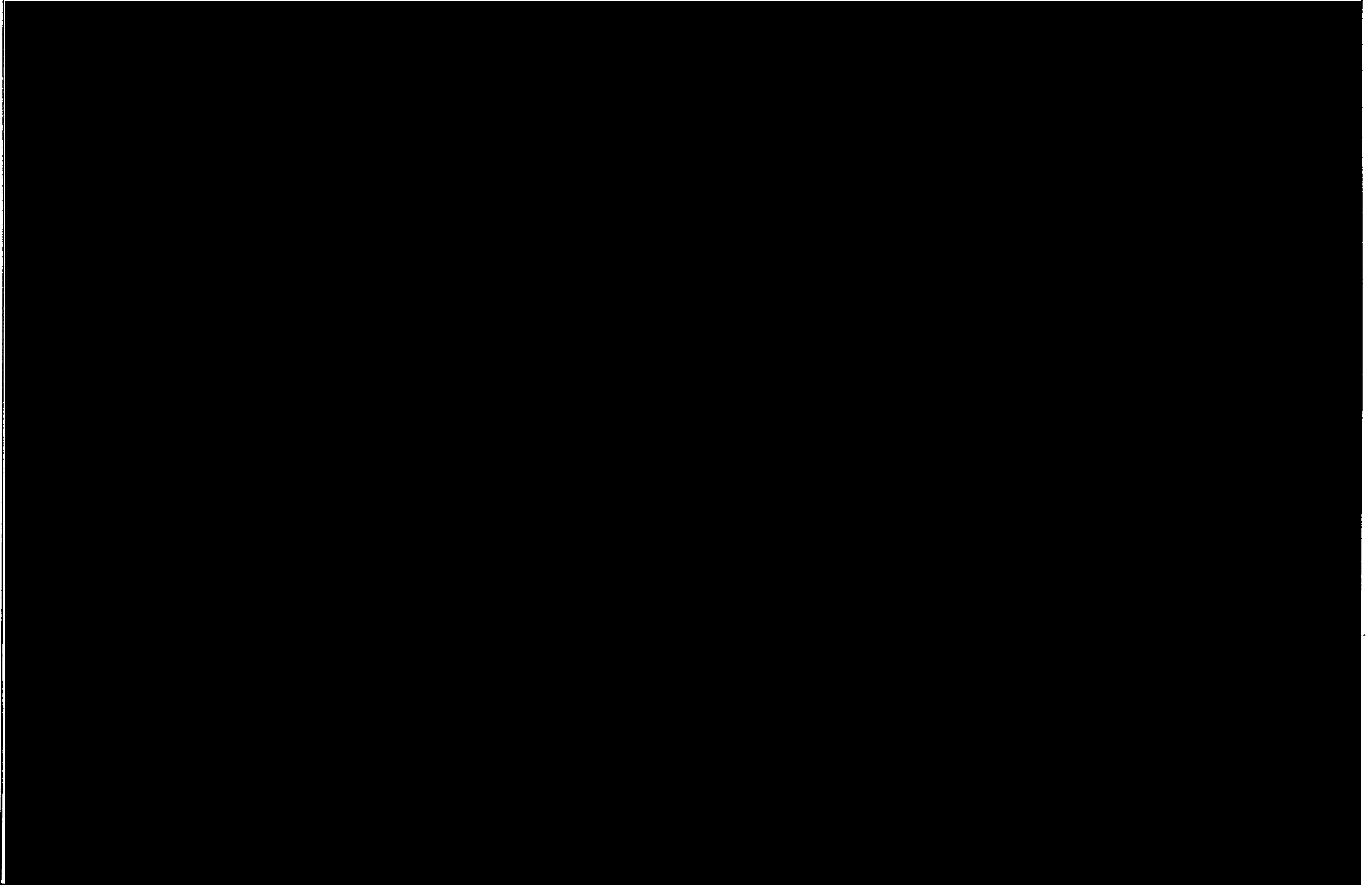

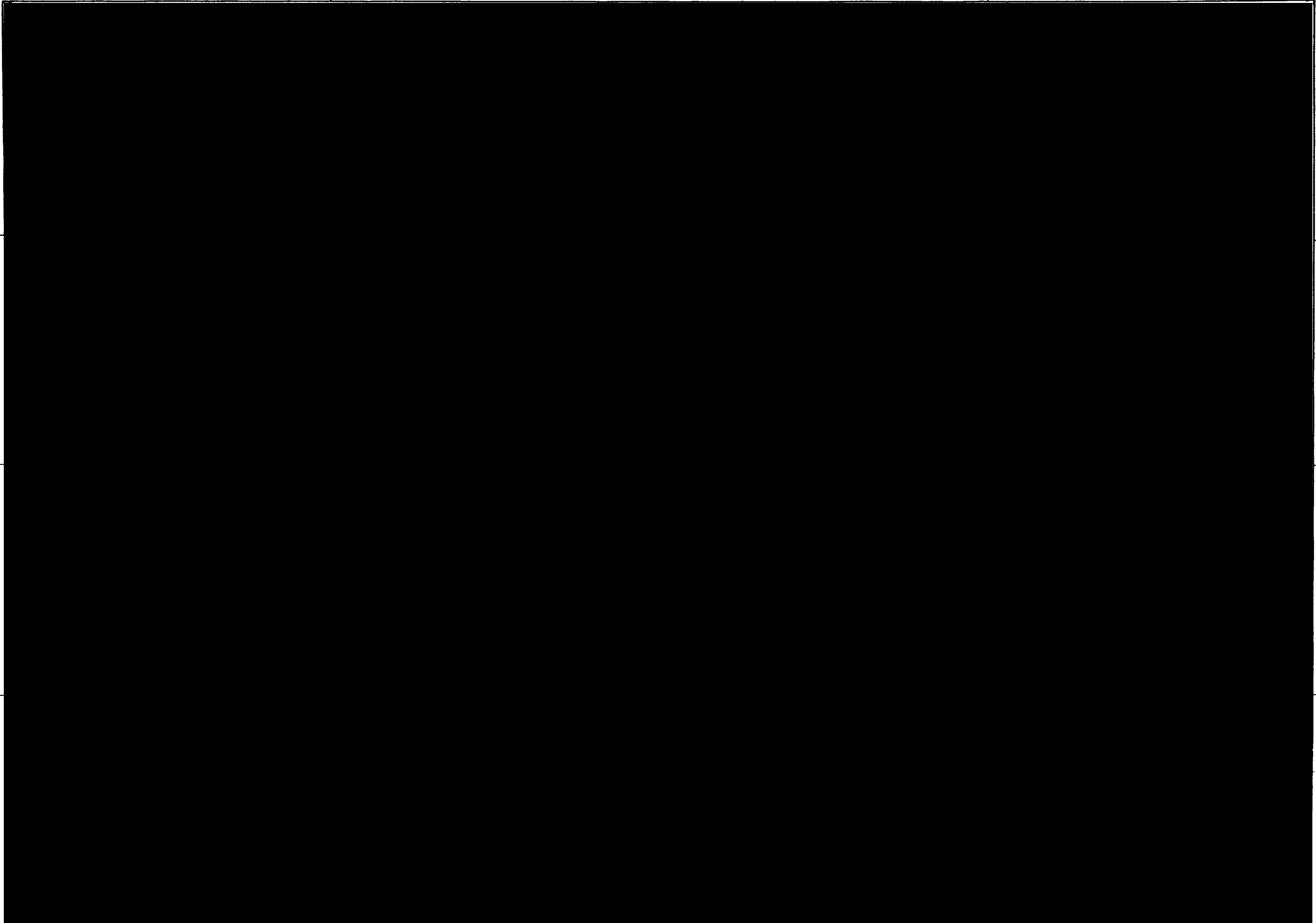

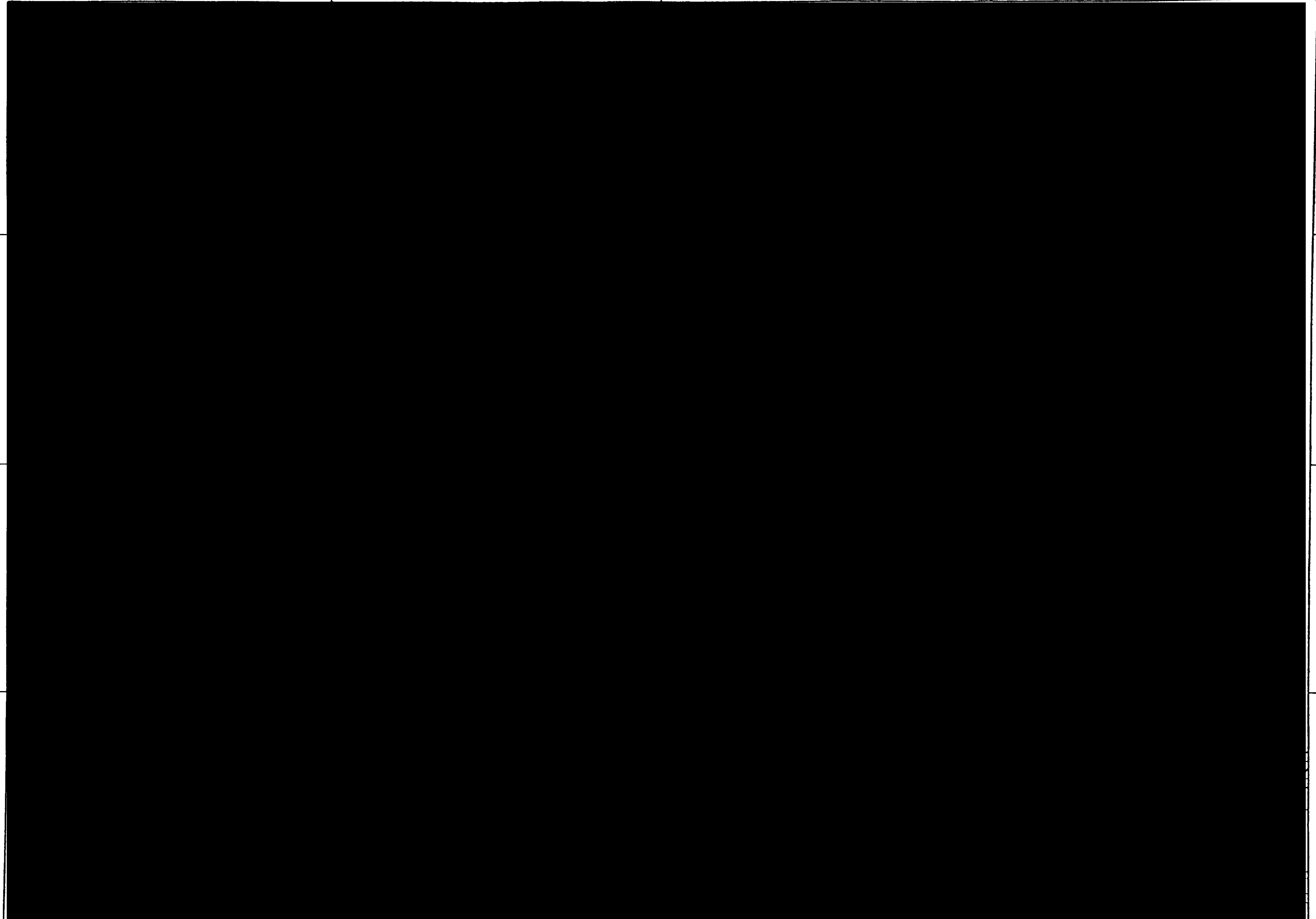

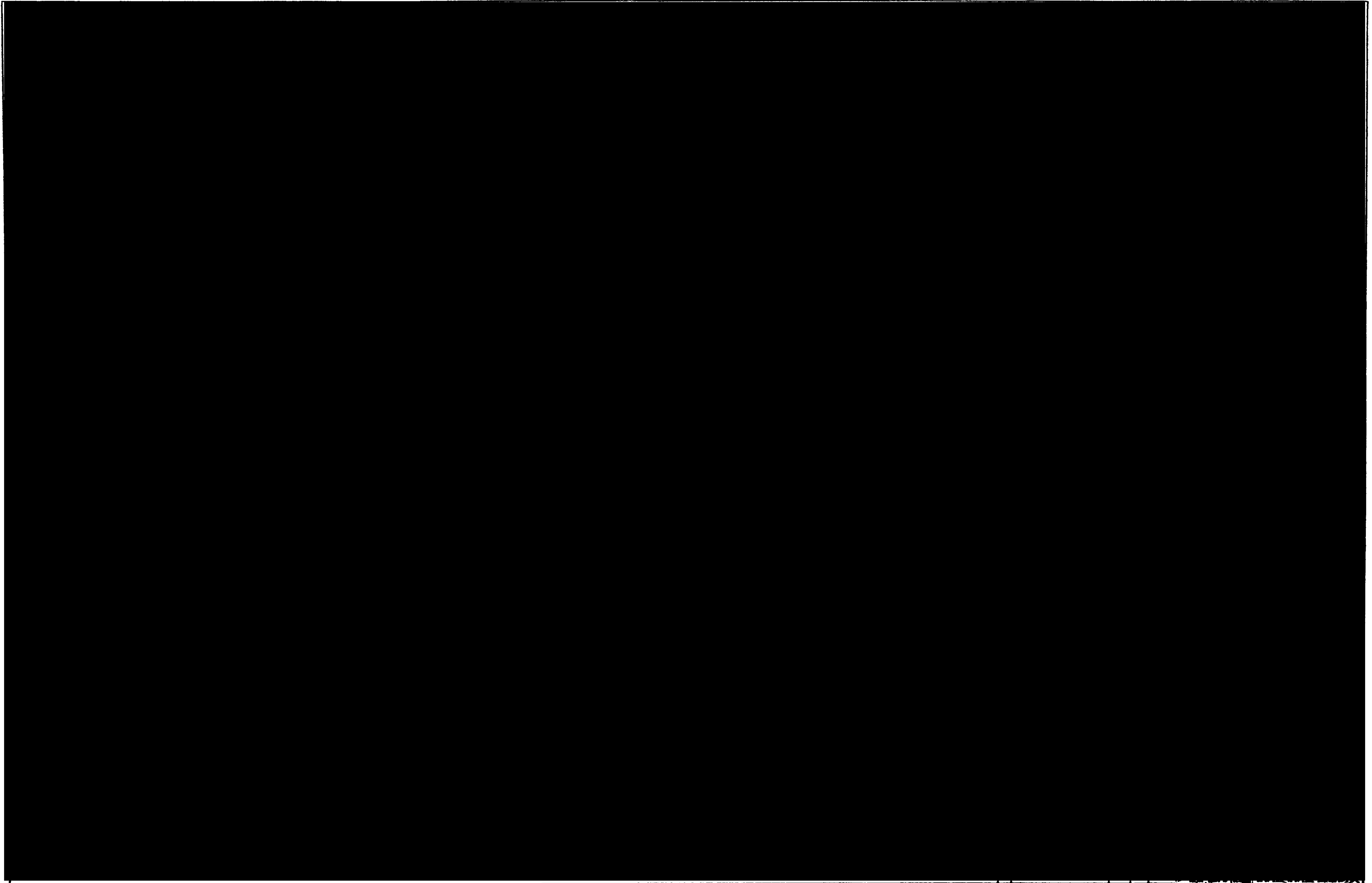

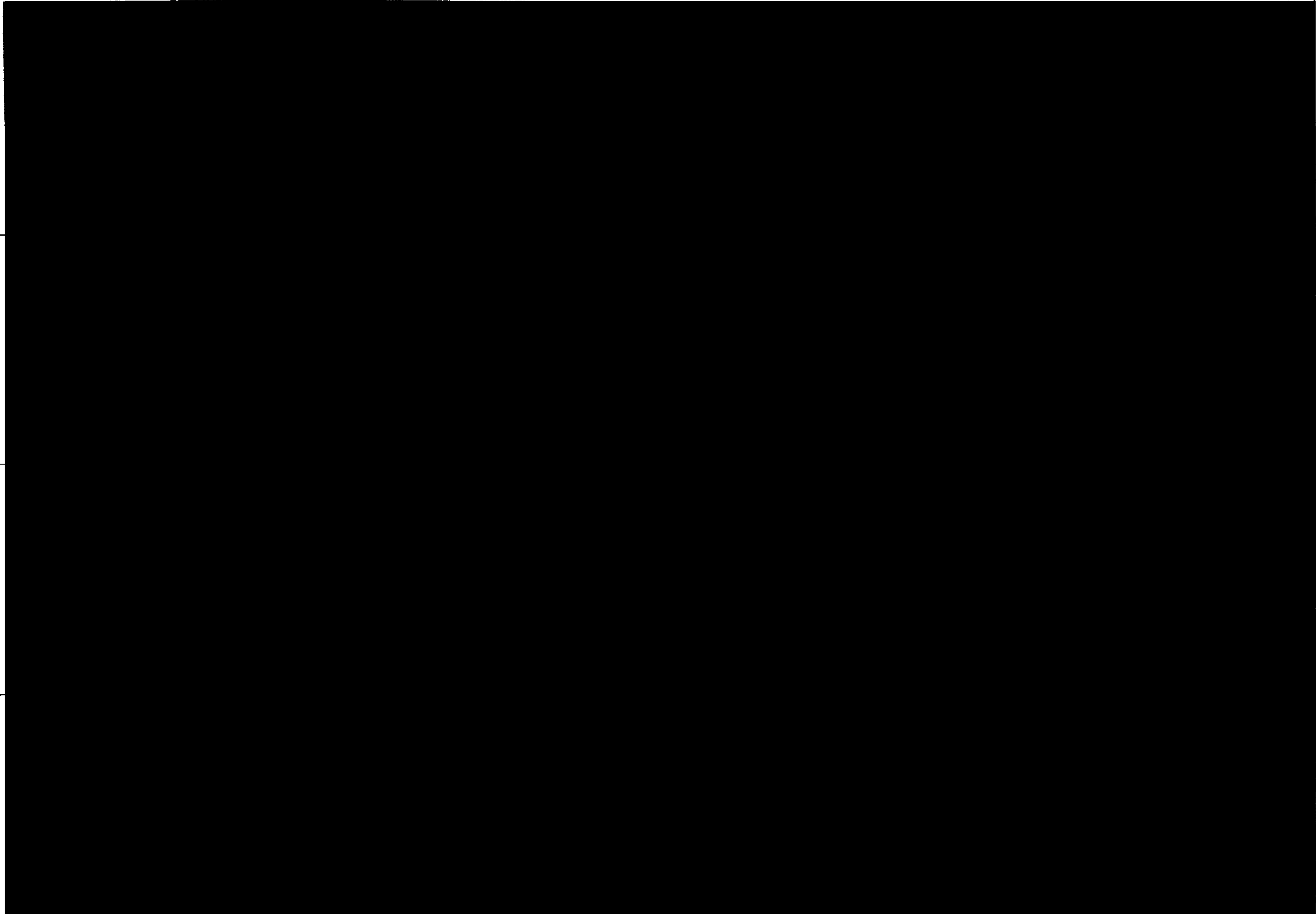

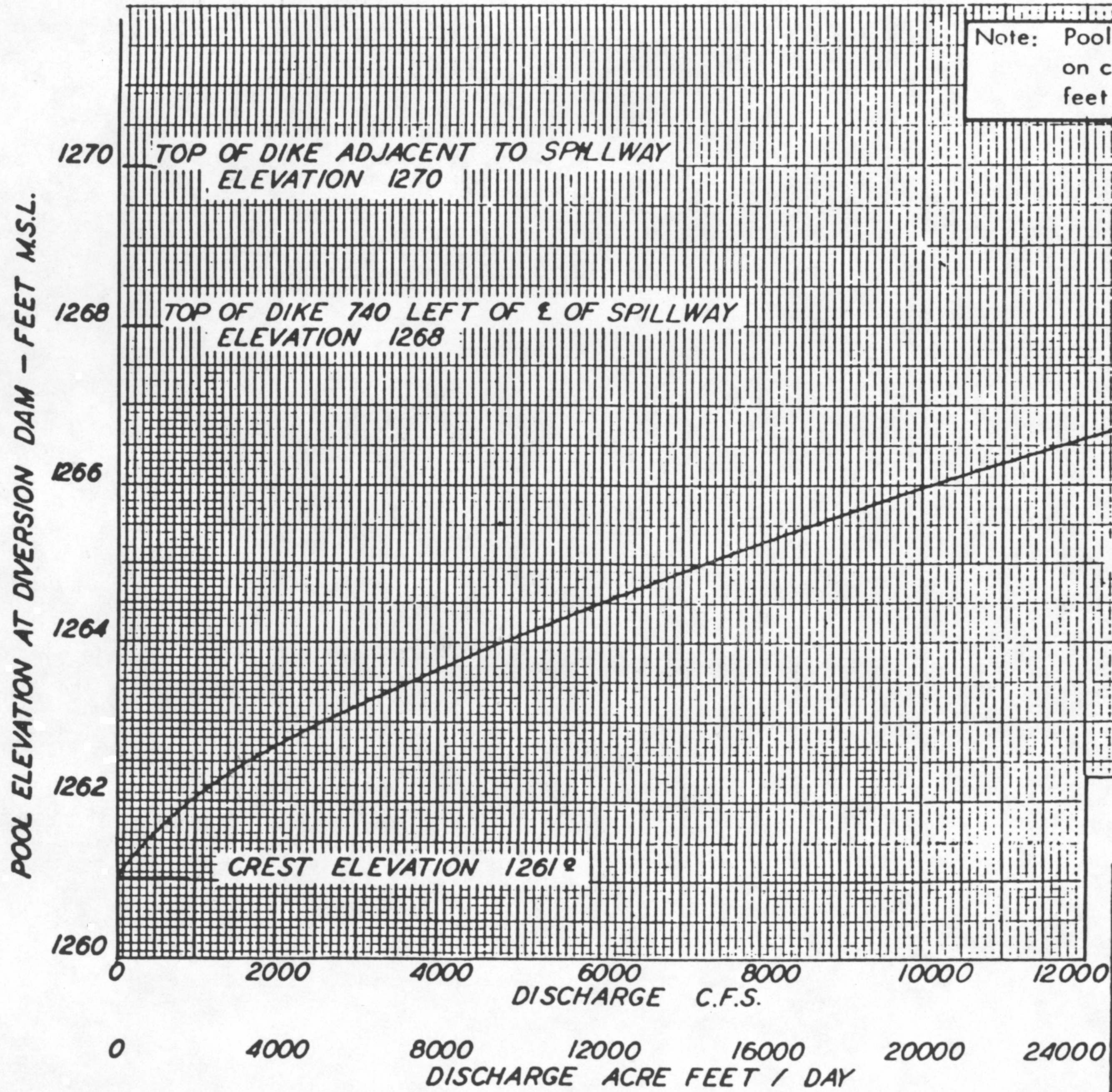

Note: Pool gage is metal staff mounted on concrete monument located 50 feet upstream from intake gates.

14000 16000
28000 32000

FLOOD REGULATION MANUAL
MILL CREEK RESERVOIR
WALLA WALLA, WASHINGTON
DIVERSION DAM
SPILLWAY DISCHARGE CURVE
WALLA WALLA DISTRICT CORPS OF ENGRS
HYDROLOGY & HYDRAULICS SECTION
PREPARED BY R.A. DATE MAY 16, 1951
CHECKED BY R.H.C.
TRACED BY D.R.

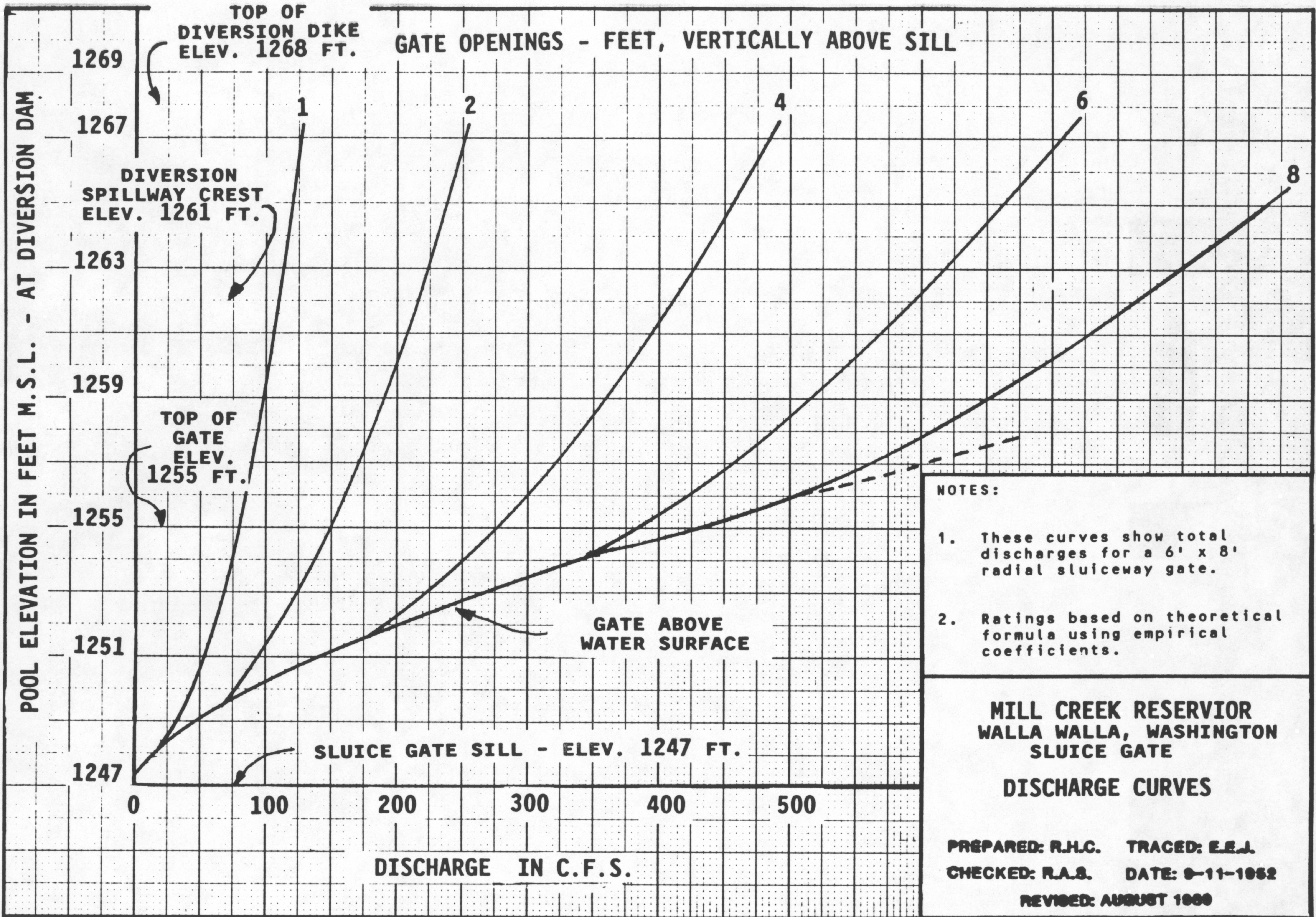

NOTES:

1. These curves show total discharges for a 6' x 8' radial sluiceway gate.
2. Ratings based on theoretical formula using empirical coefficients.

**MILL CREEK RESERVIOR
WALLA WALLA, WASHINGTON
SLUICE GATE**

DISCHARGE CURVES

PREPARED: R.H.C. TRACED: E.E.J.
 CHECKED: R.A.S. DATE: 9-11-1962
 REVISED: AUGUST 1960

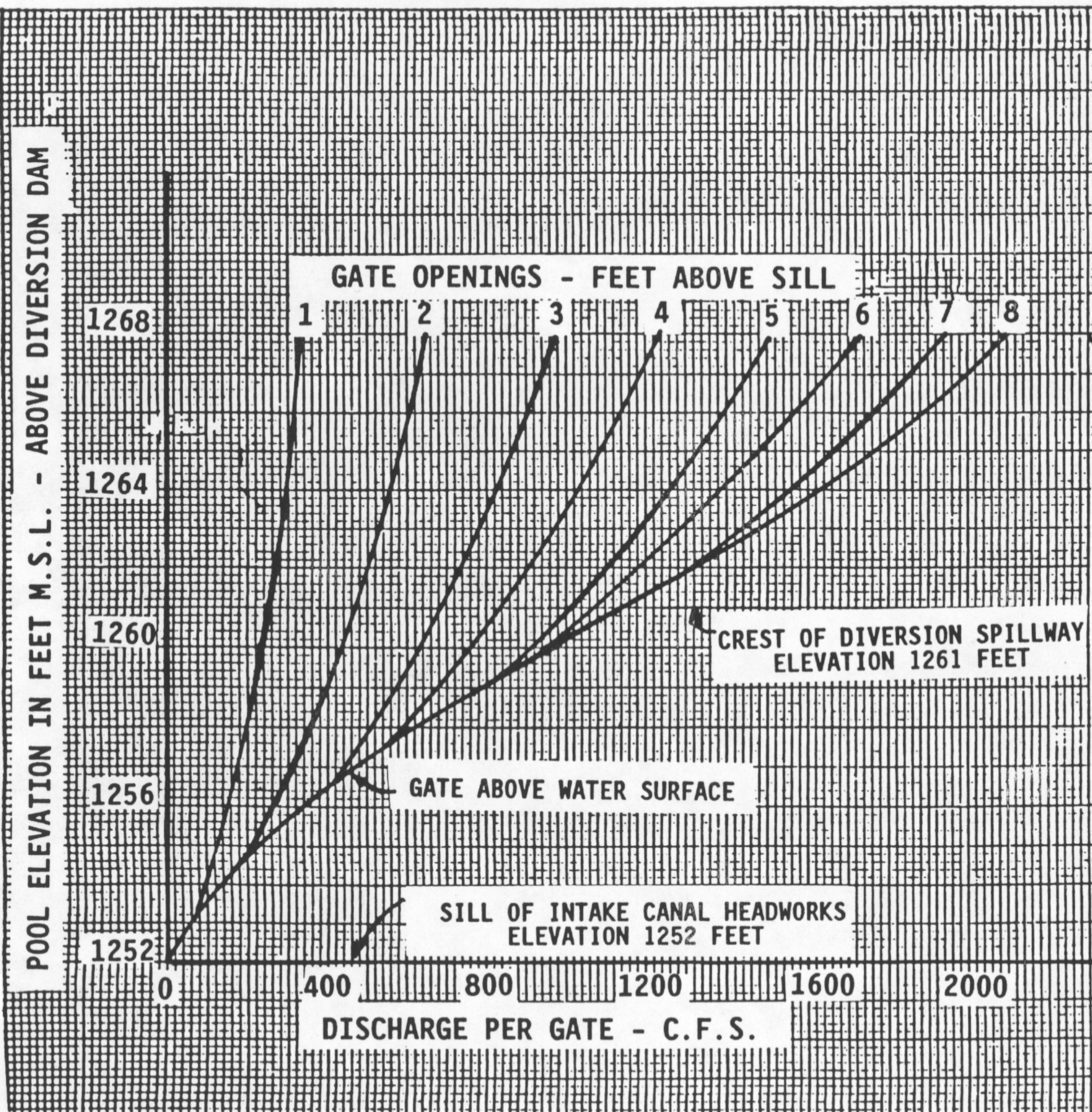

Notes:

1. These curves applicable for any one of four identical 8'x18' radial gated openings in the intake canal headworks.
2. Total discharge through the four openings, is considered to be the sum of discharges under individual gates.
3. Ratings based on theoretical formulas using empirical coefficients.

FLOOD REGULATION MANUAL
 MILL CREEK RESERVOIR
 WALLA WALLA, WASHINGTON
 INTAKE CANAL HEADWORKS
 DISCHARGE CURVES

WALLA WALLA DISTRICT, CORPS OF ENGINEERS
 HYDROLOGY & HYDRAULICS SECTION

PREPARED: R.H.C. CHECKED: R.A.S.
 TRACED: E.E.J. DATE: 9-30-1952

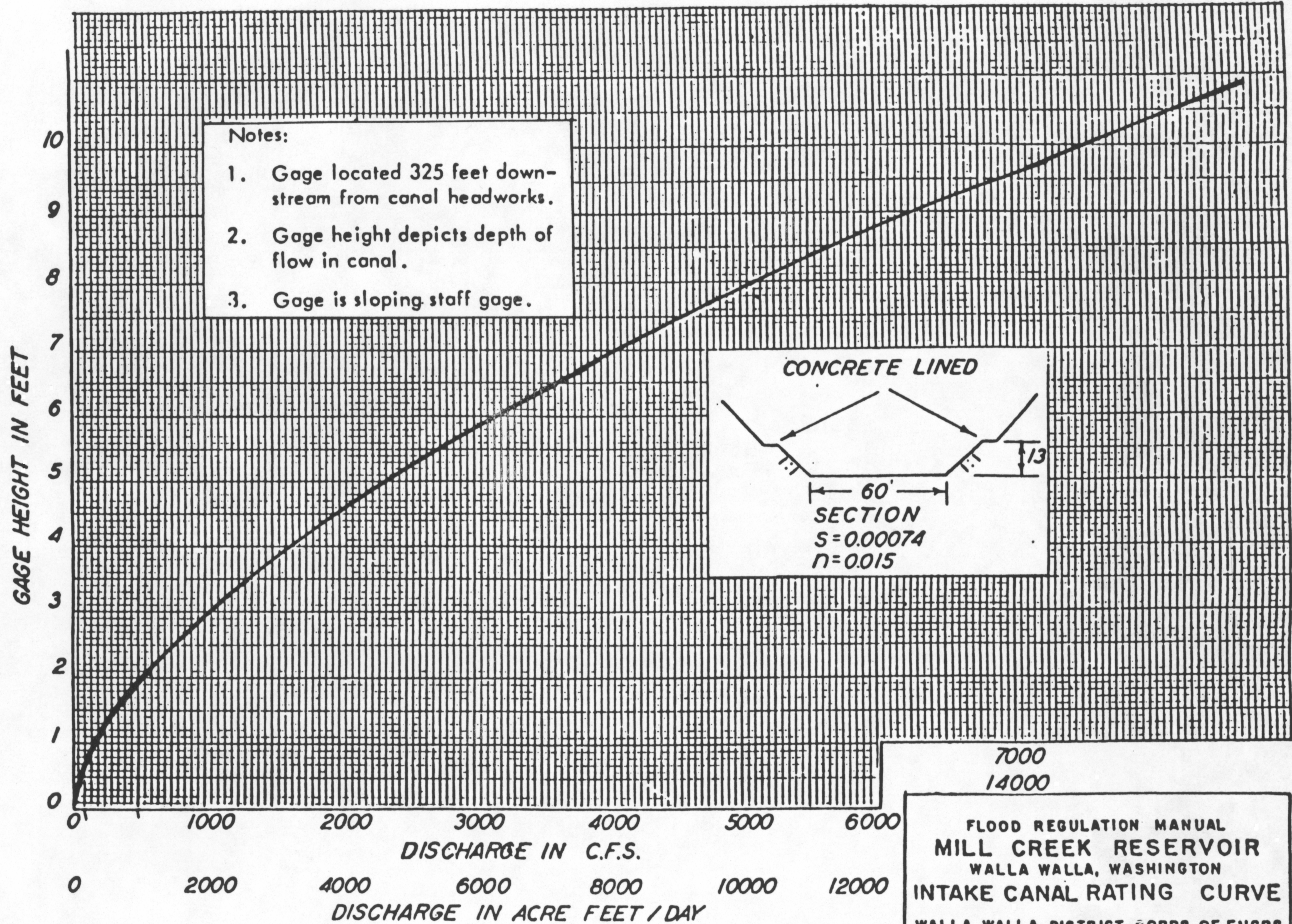

7000
14000

**FLOOD REGULATION MANUAL
 MILL CREEK RESERVOIR
 WALLA WALLA, WASHINGTON
 INTAKE CANAL RATING CURVE**

WALLA WALLA DISTRICT CORPS OF ENGRS
 HYDROLOGY & HYDRAULICS SECTION

PREPARED BY R. A. DATE: MAY 16, 1981
 CHECKED BY R. N. G.
 TRACED BY...D.R.

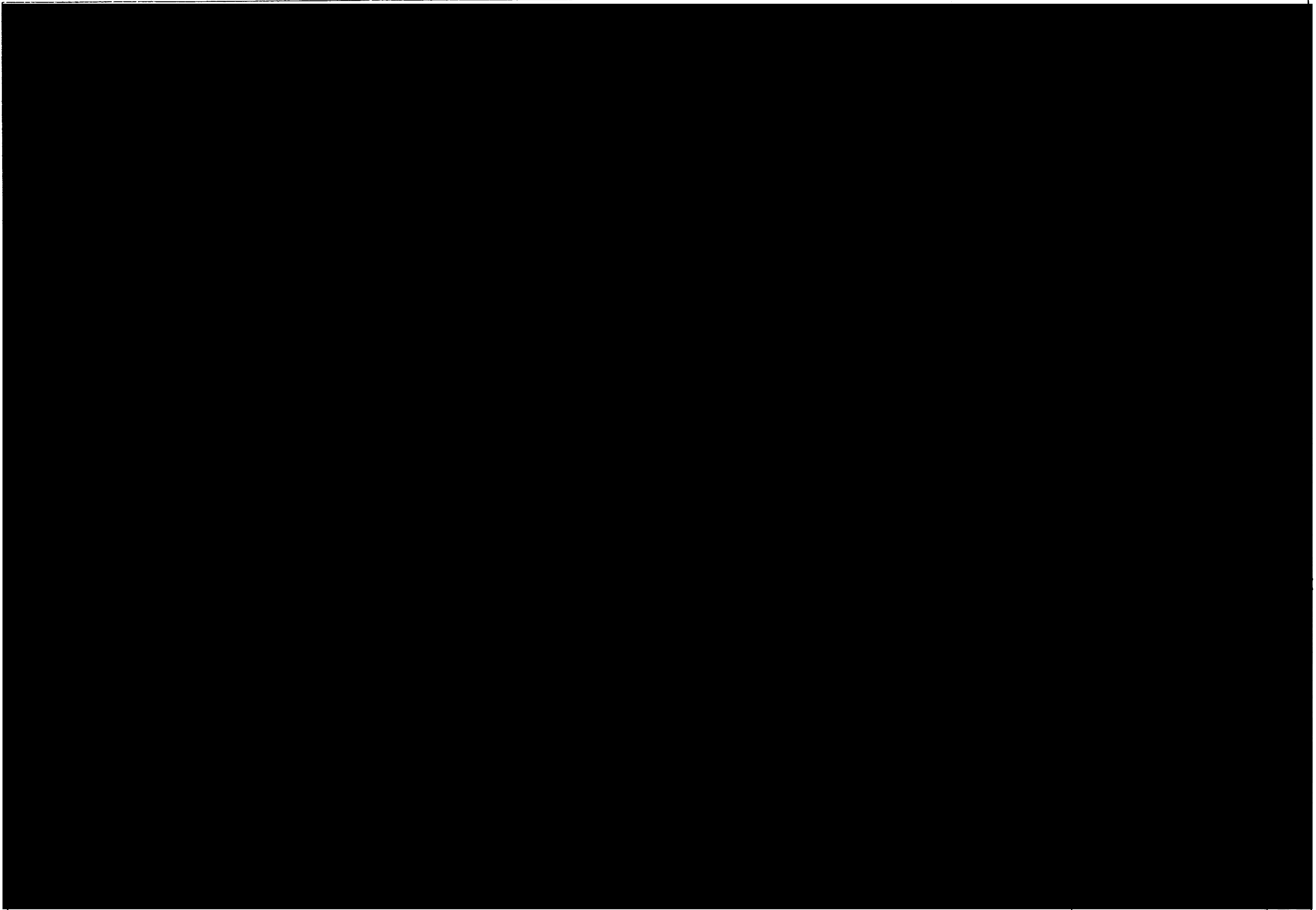

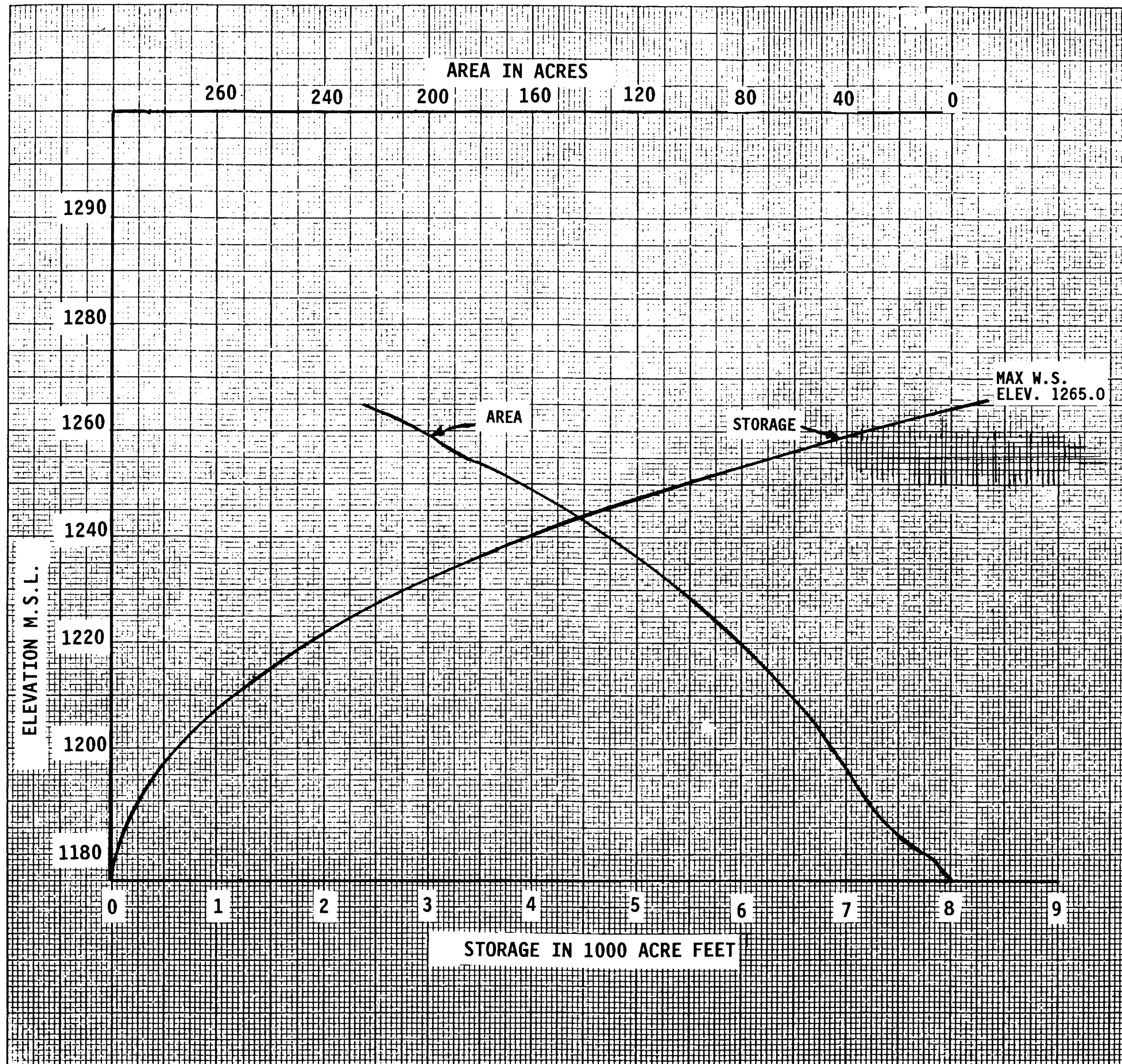

Elevation Feet M. S. L.	Storage Acre-feet	Elevation Feet M. S. L.	Storage Acre-feet
1180	16	1223	2109
1181	30	1224	2197
1182	45	1225	2286
1183	61	1226	2378
1184	79	1227	2474
1185	100	1228	2573
1186	122	1229	2675
1187	146	1230	2779
1188	172	1231	2885
1189	202	1232	2993
1190	235	1233	3103
1191	269	1234	3215
1192	304	1235	3330
1193	339	1236	3448
1194	375	1237	3568
1195	411	1238	3691
1196	448	1239	3817
1197	487	1240	3946
1198	529	1241	4078
1199	574	1242	4213
1200	621	1243	4351
1201	668	1244	4492
1202	716	1245	4635
1203	765	1246	4782
1204	815	1247	4932
1205	866	1248	5086
1206	919	1249	5244
1207	975	1250	5405
1208	1034	1251	5570
1209	1095	1252	5739
1210	1158	1253	5913
1211	1221	1254	6092
1212	1284	1255	6275
1213	1347	1256	6462
1214	1410	1257	6653
1215	1474	1258	6848
1216	1541	1259	7047
1217	1612	1260	7251
1218	1687	1261	7459
1219	1767	1262	7671
1220	1851	1263	7886
1221	1936	1264	8105
1222	2022	1265	8327

Flood Regulation Manual
MILL CREEK RESERVOIR
Walla Walla, Washington
CAPACITY CURVE
U.S. Army Engr. Dist., Walla Walla
Hydrology & Hydraulics Section

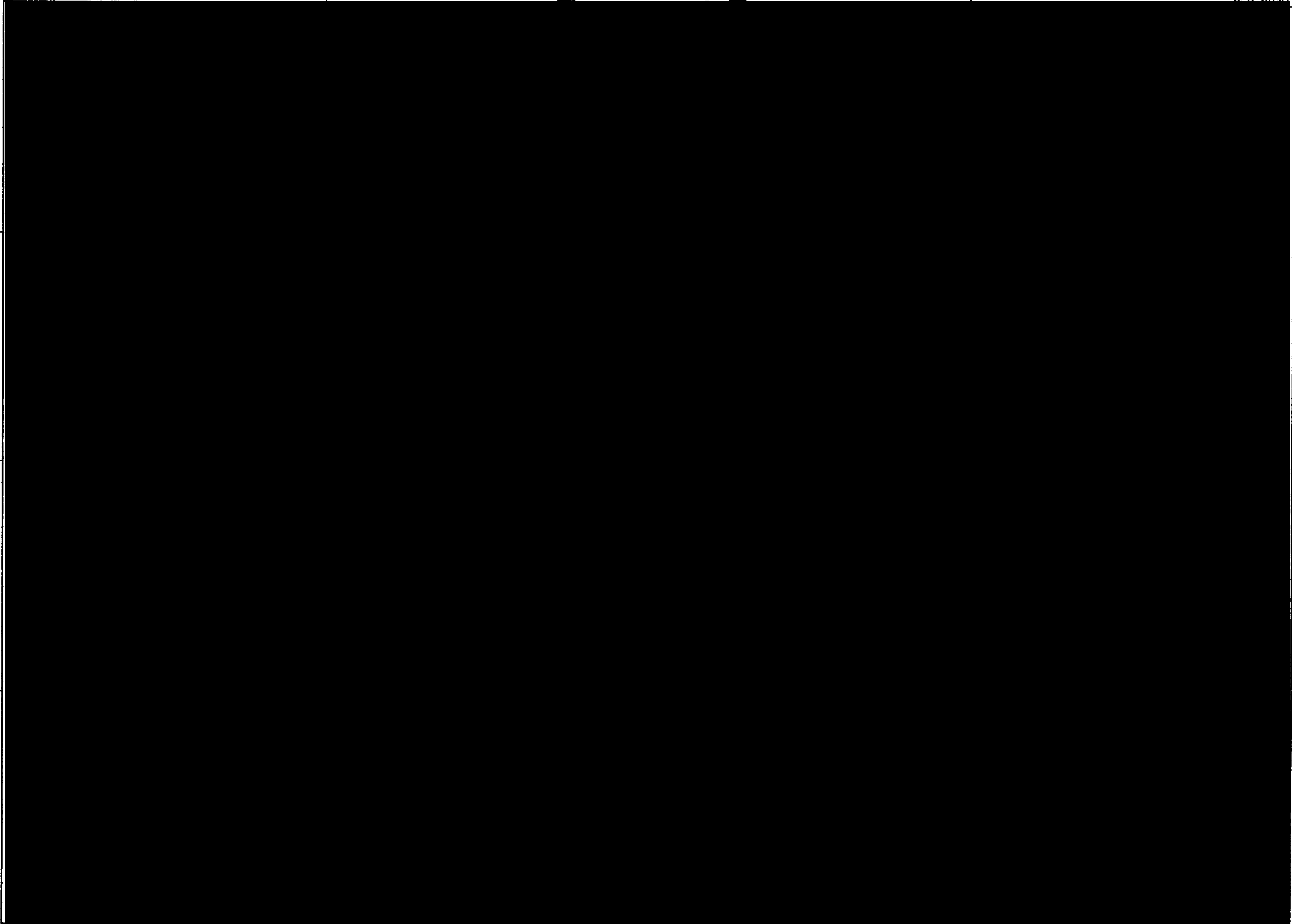

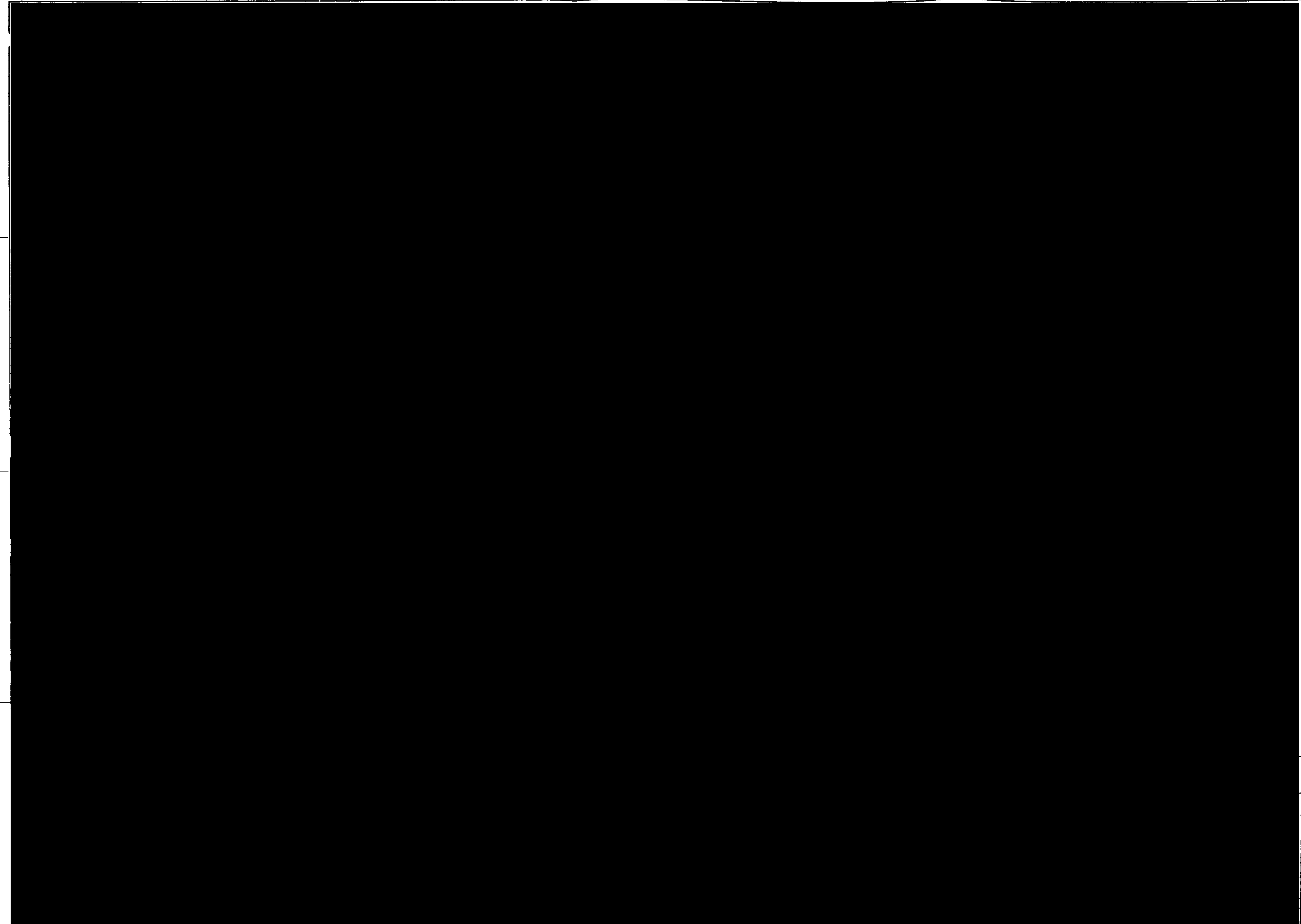

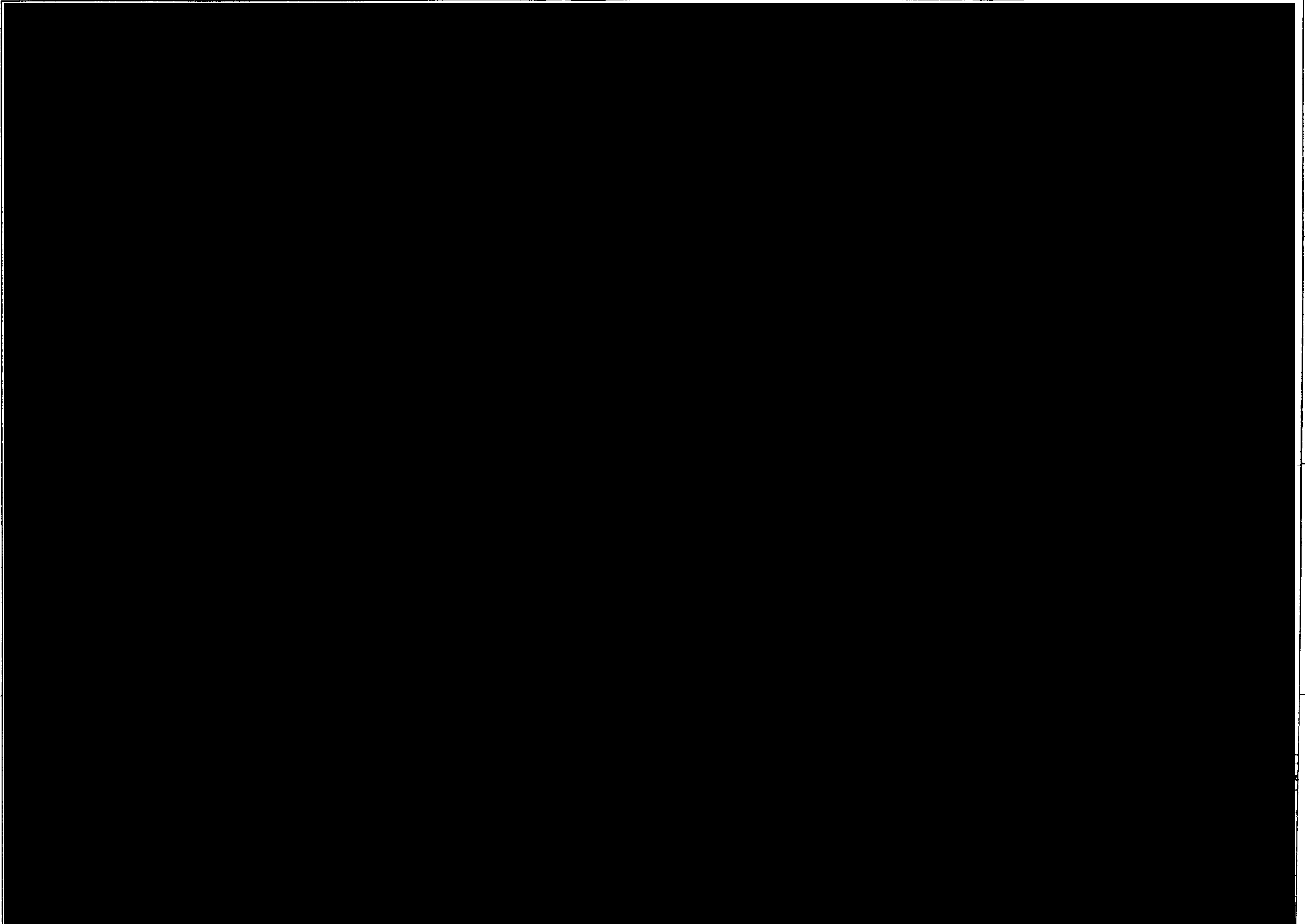

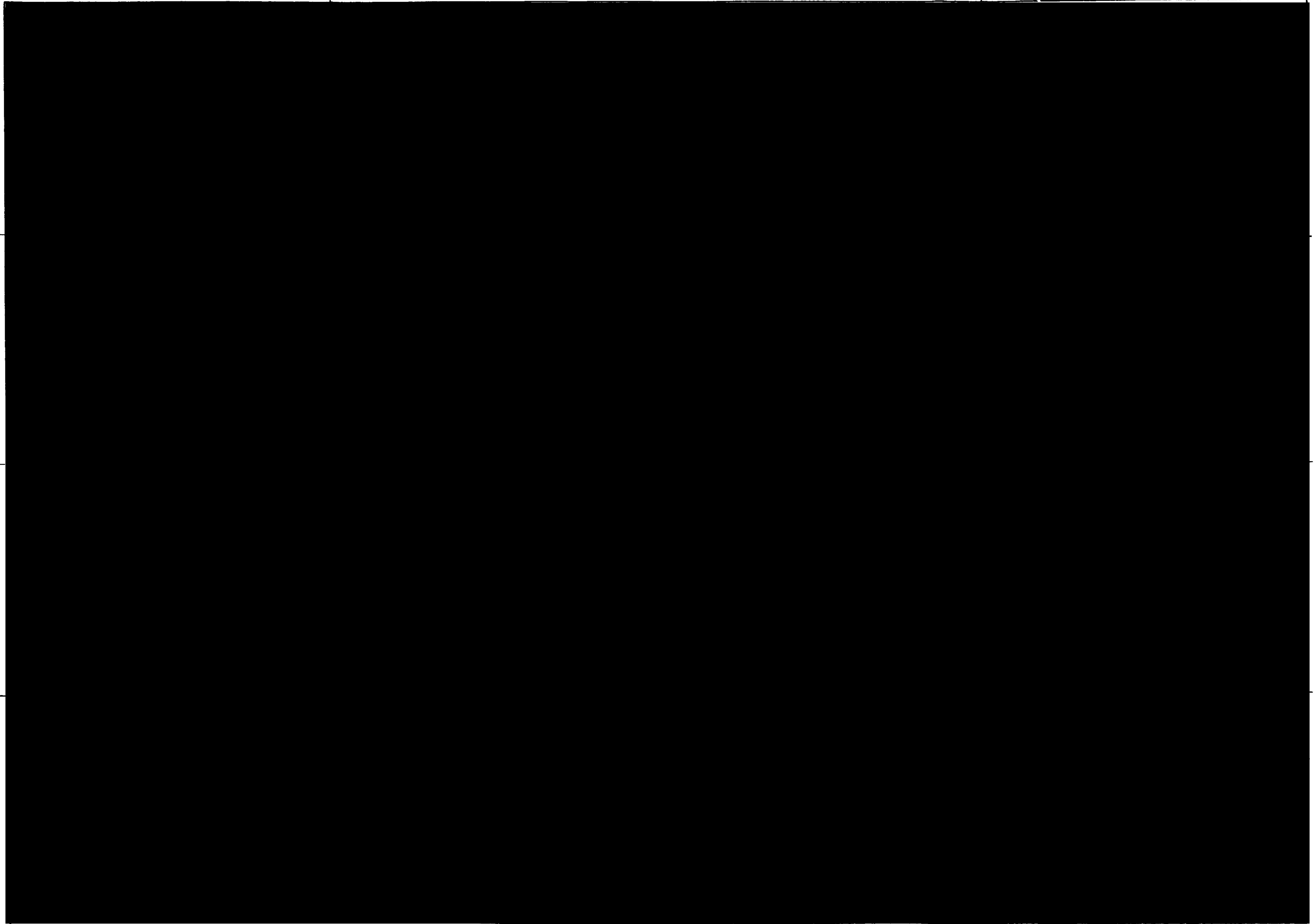

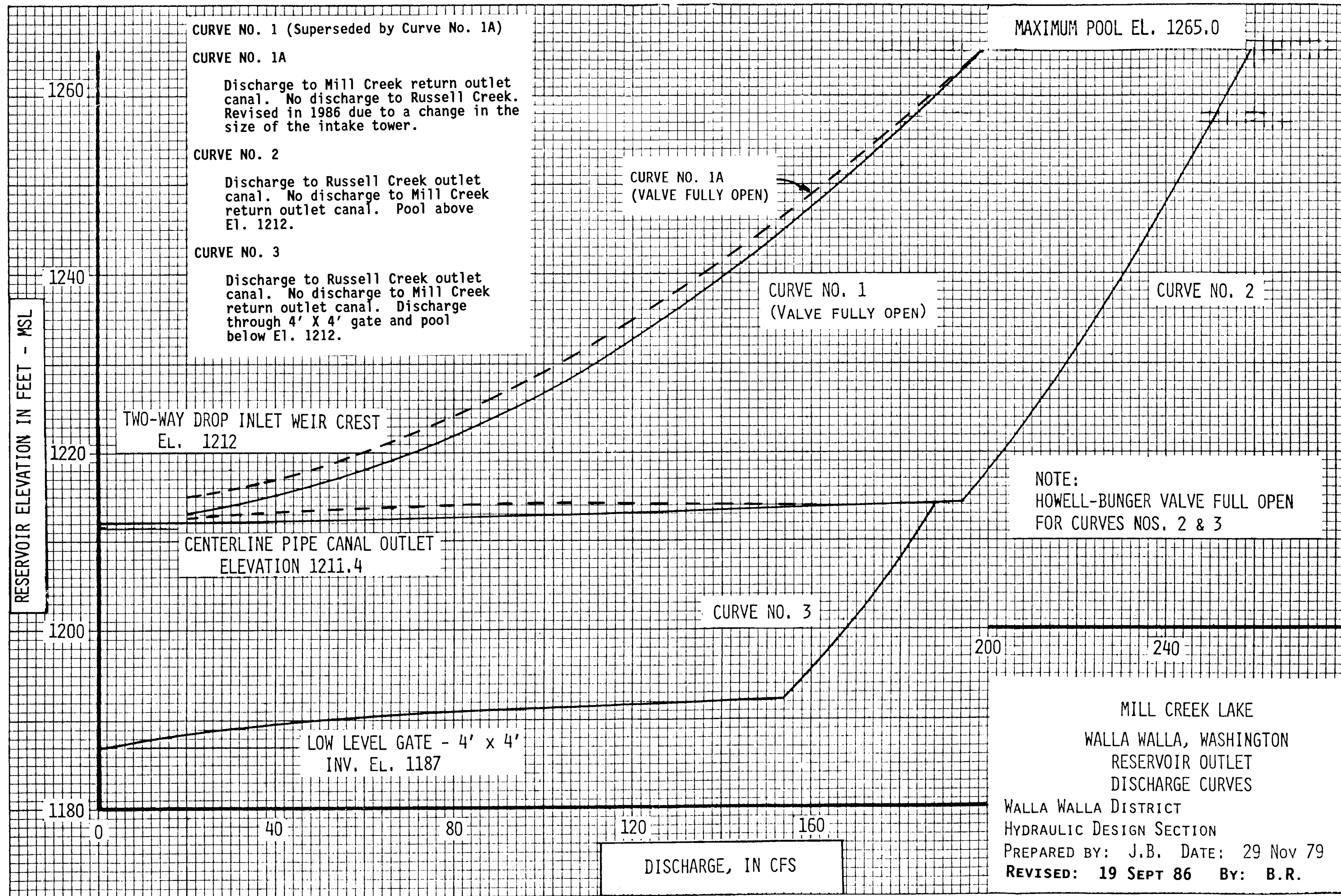

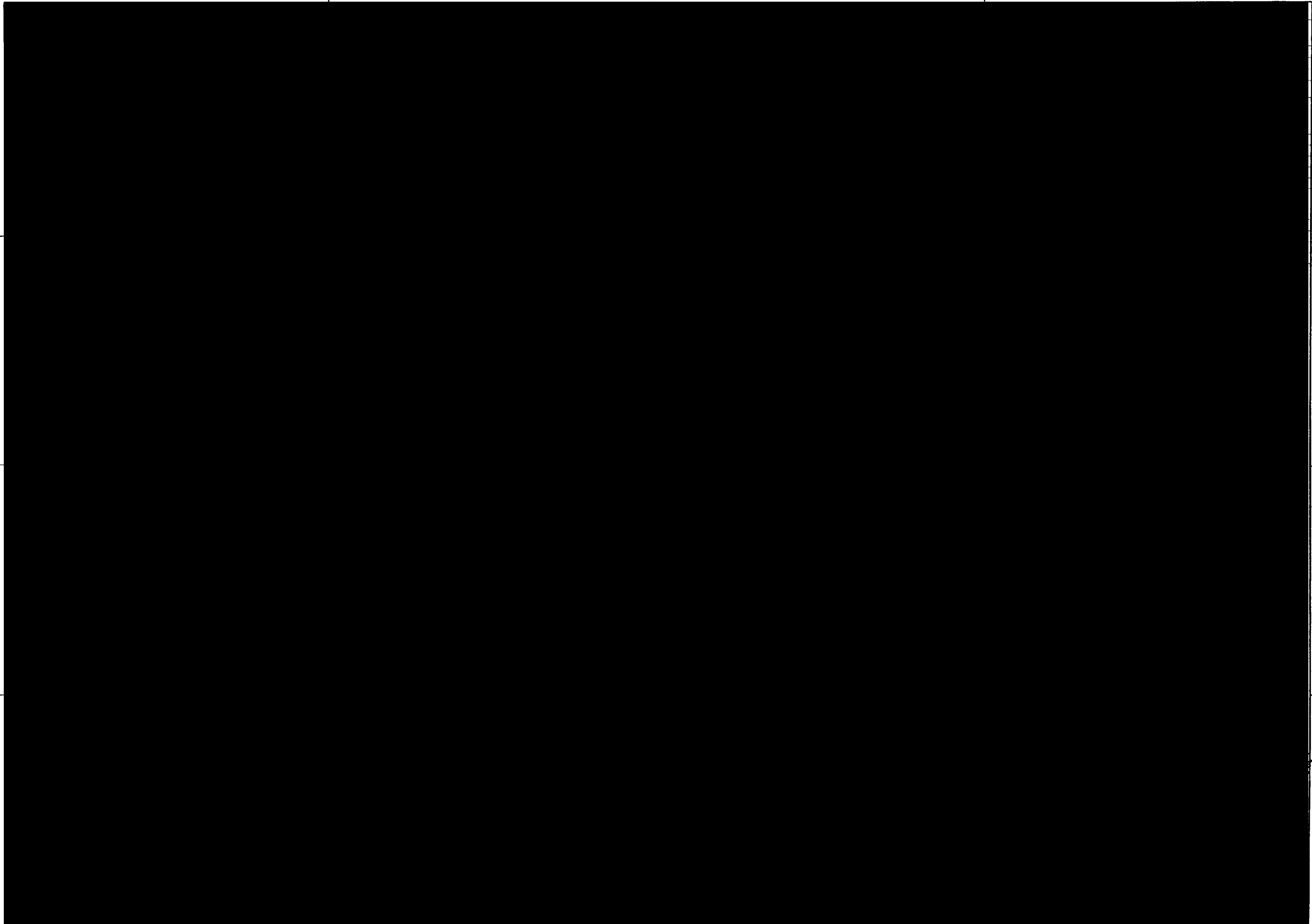

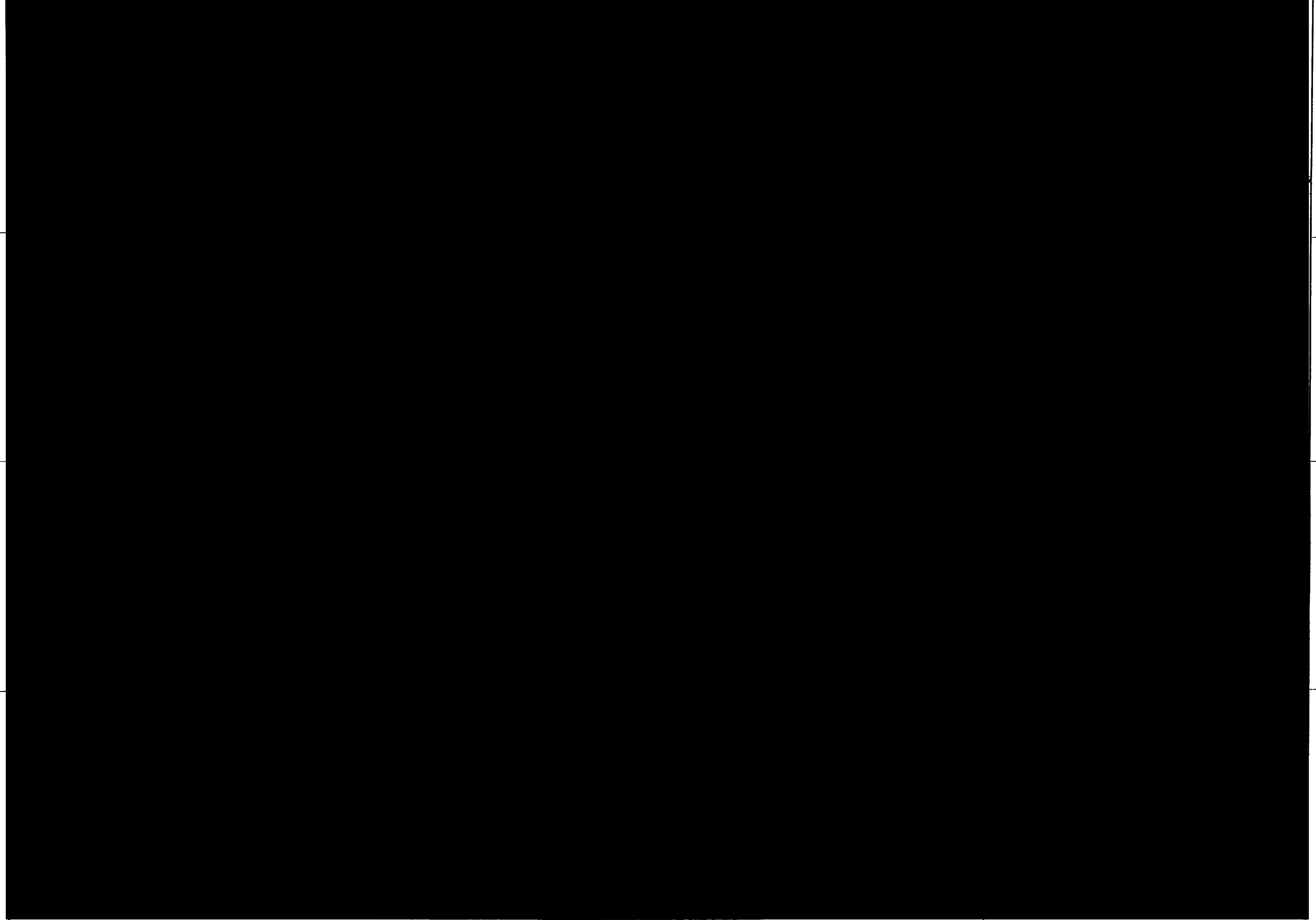

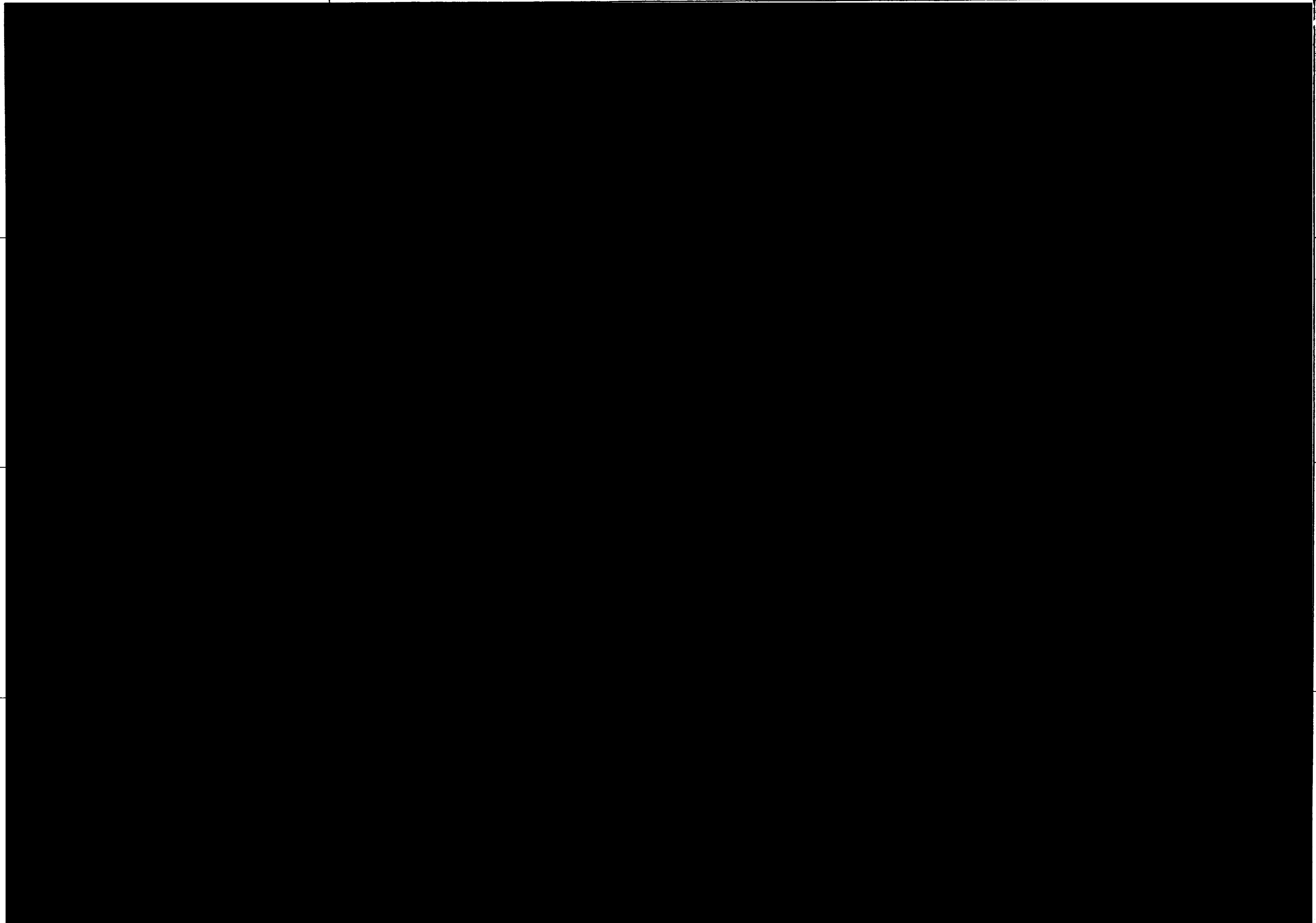

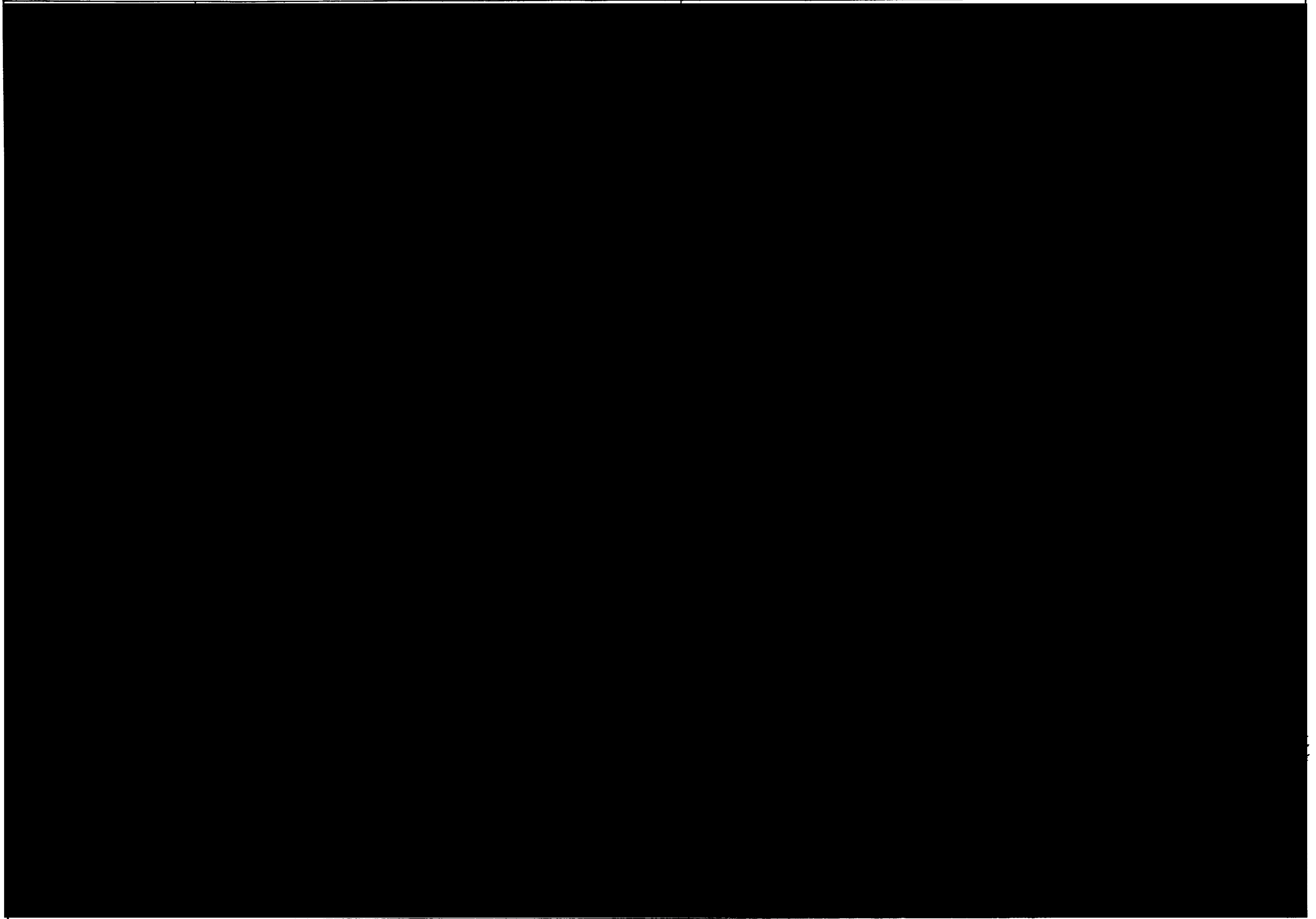

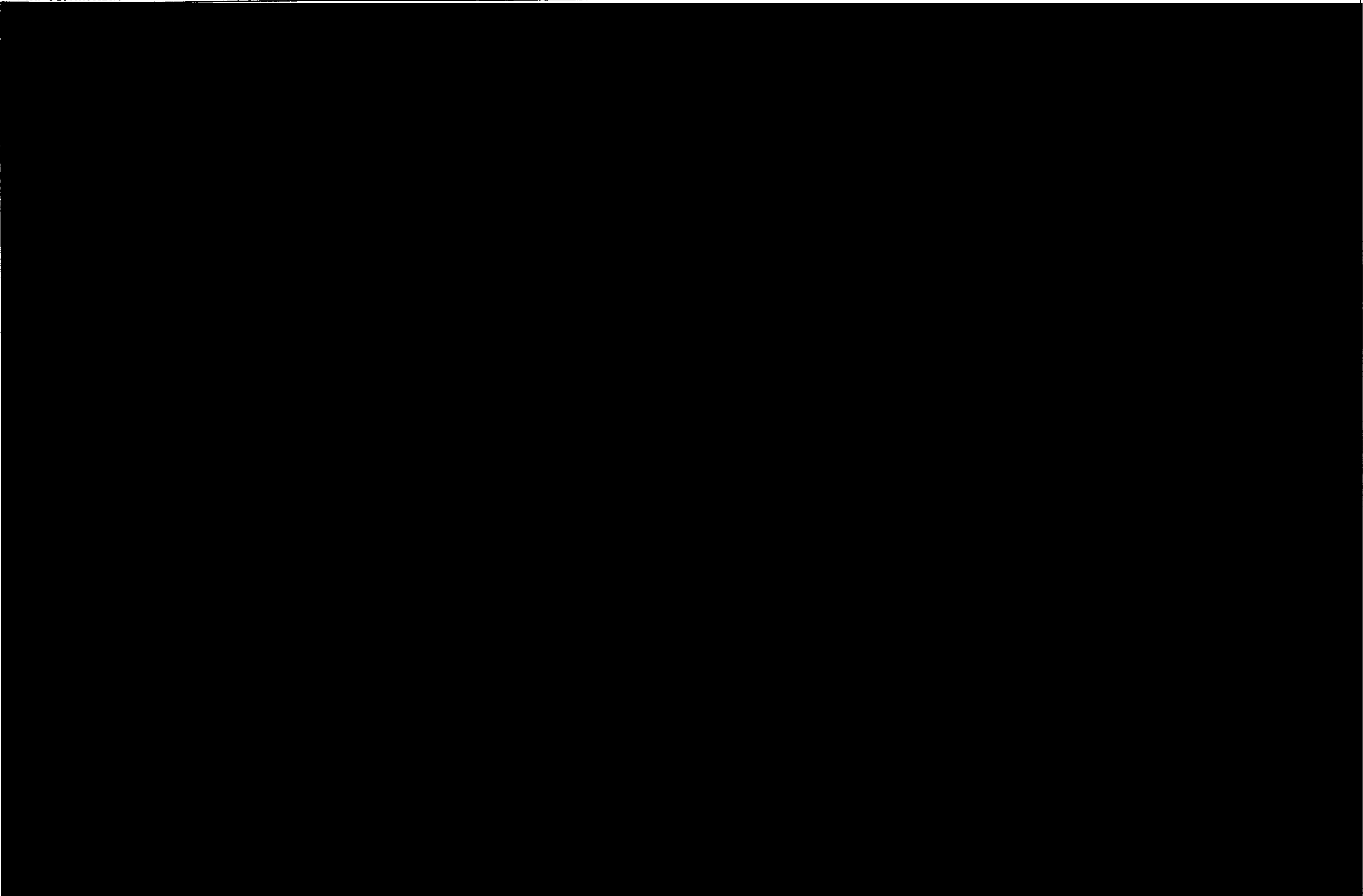

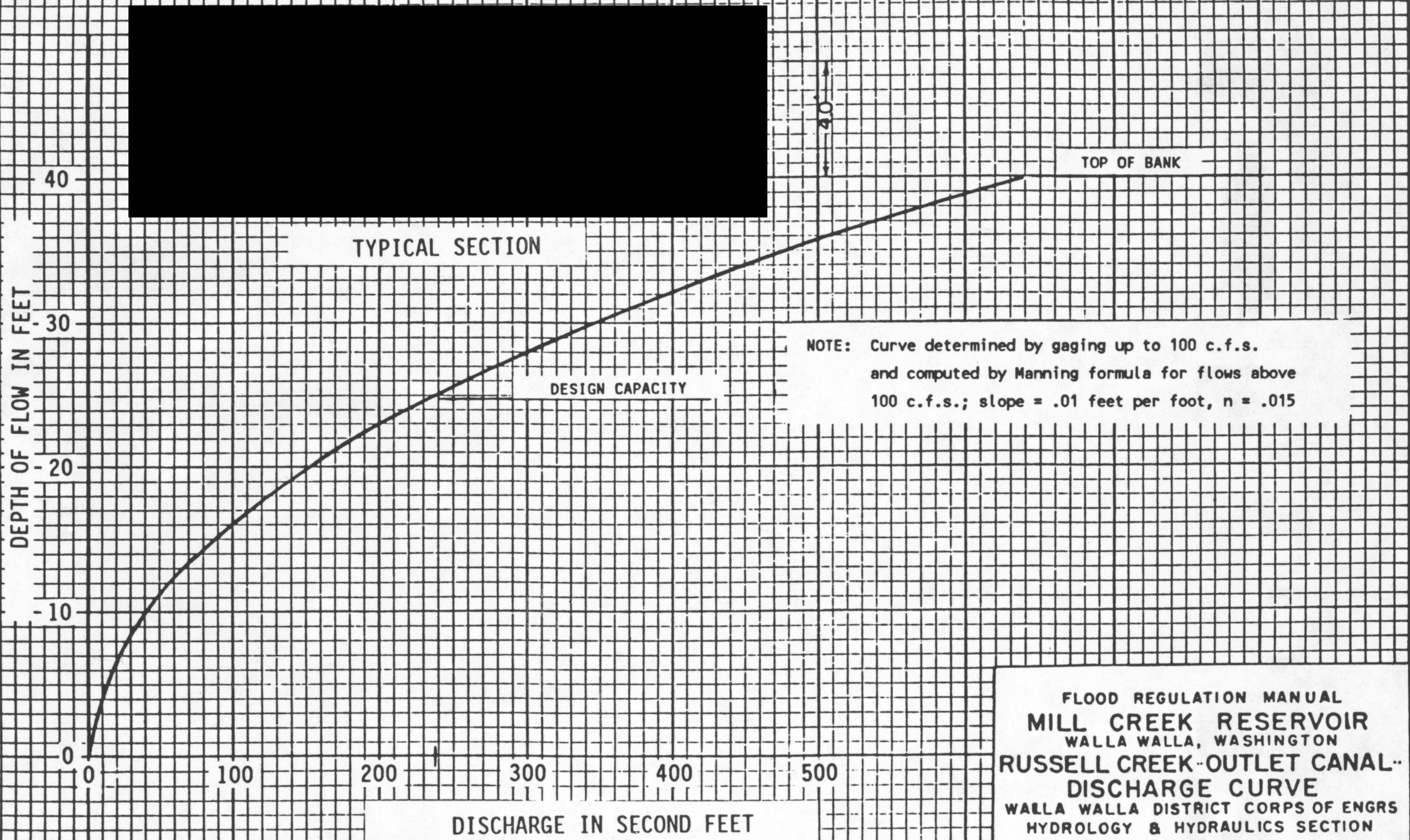

FLOOD REGULATION MANUAL
MILL CREEK RESERVOIR
WALLA WALLA, WASHINGTON
RUSSELL CREEK-OUTLET CANAL
DISCHARGE CURVE
WALLA WALLA DISTRICT CORPS OF ENGRS
HYDROLOGY & HYDRAULICS SECTION
PREPARED BY R.A. DATE: MAY 16, 1951
CHECKED BY R.M.C.
TRACED BY FNA



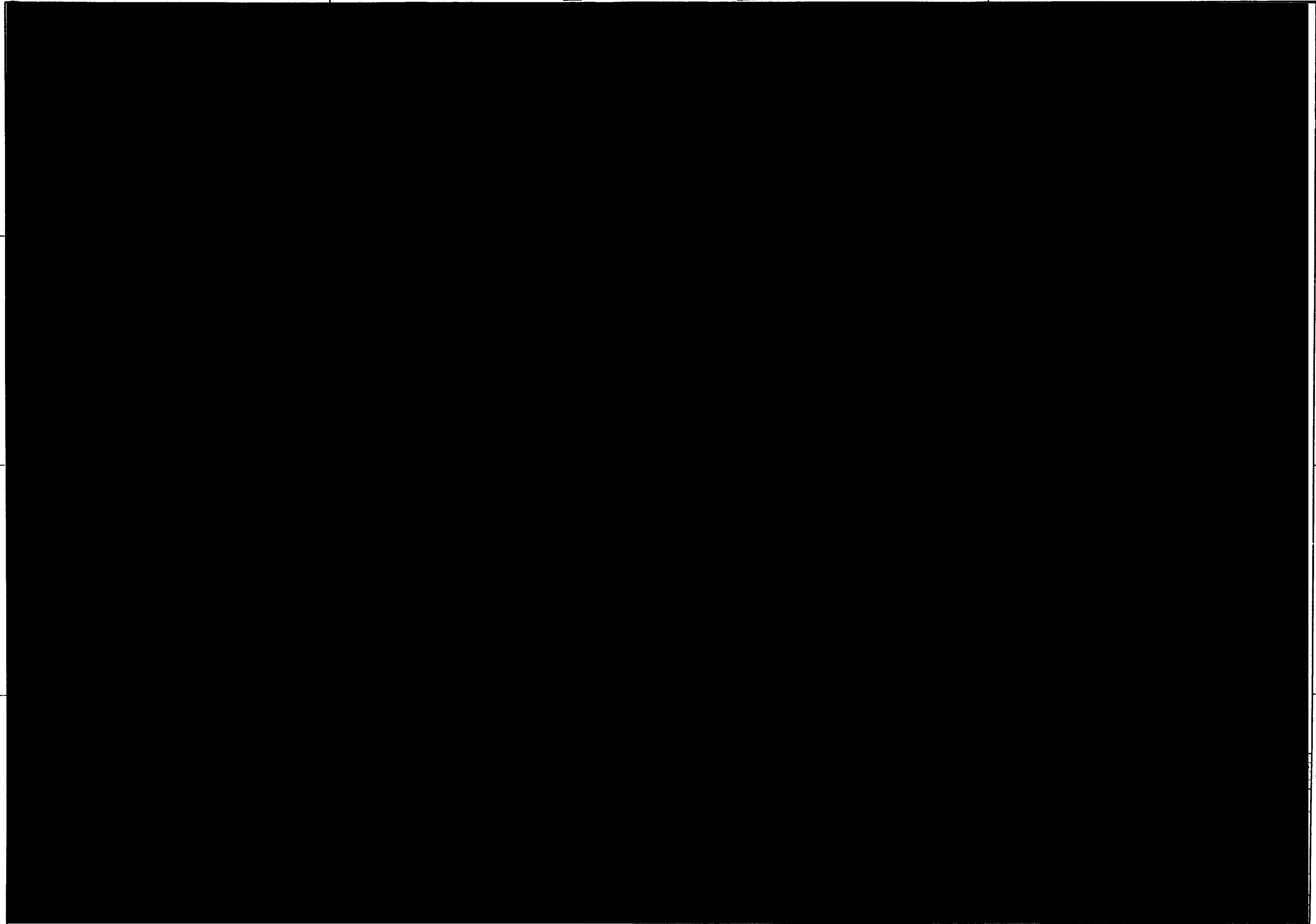

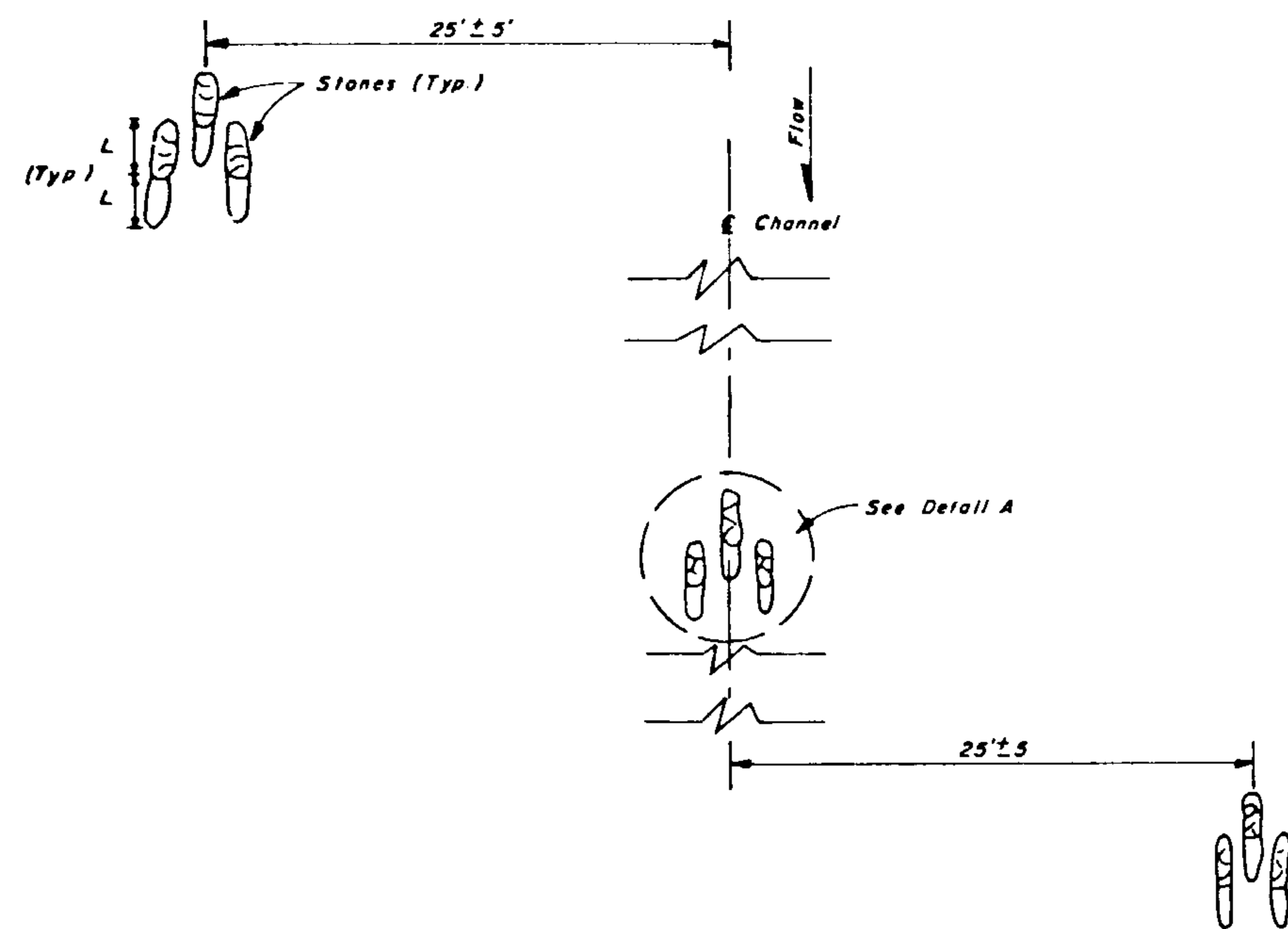
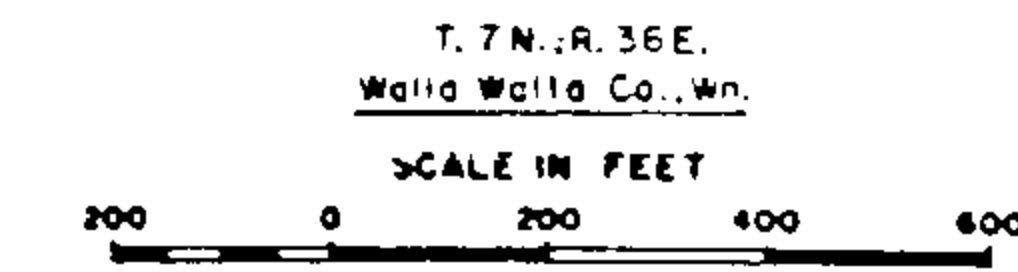
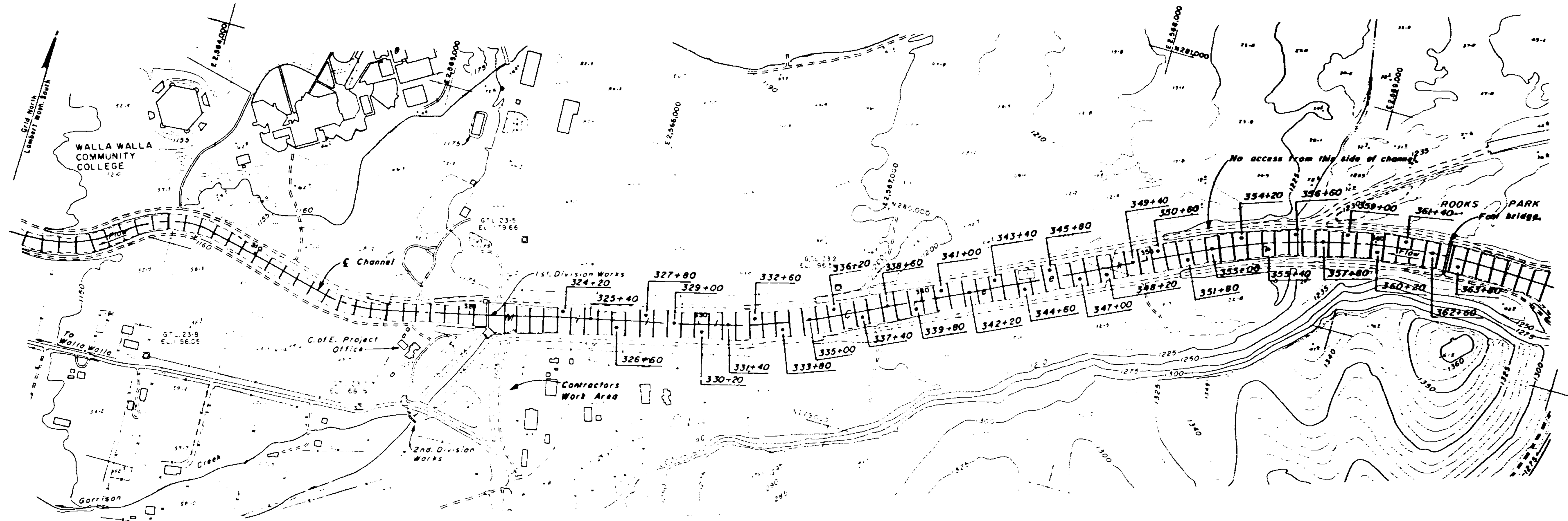

DETAIL PLAN
NOT TO SCALE

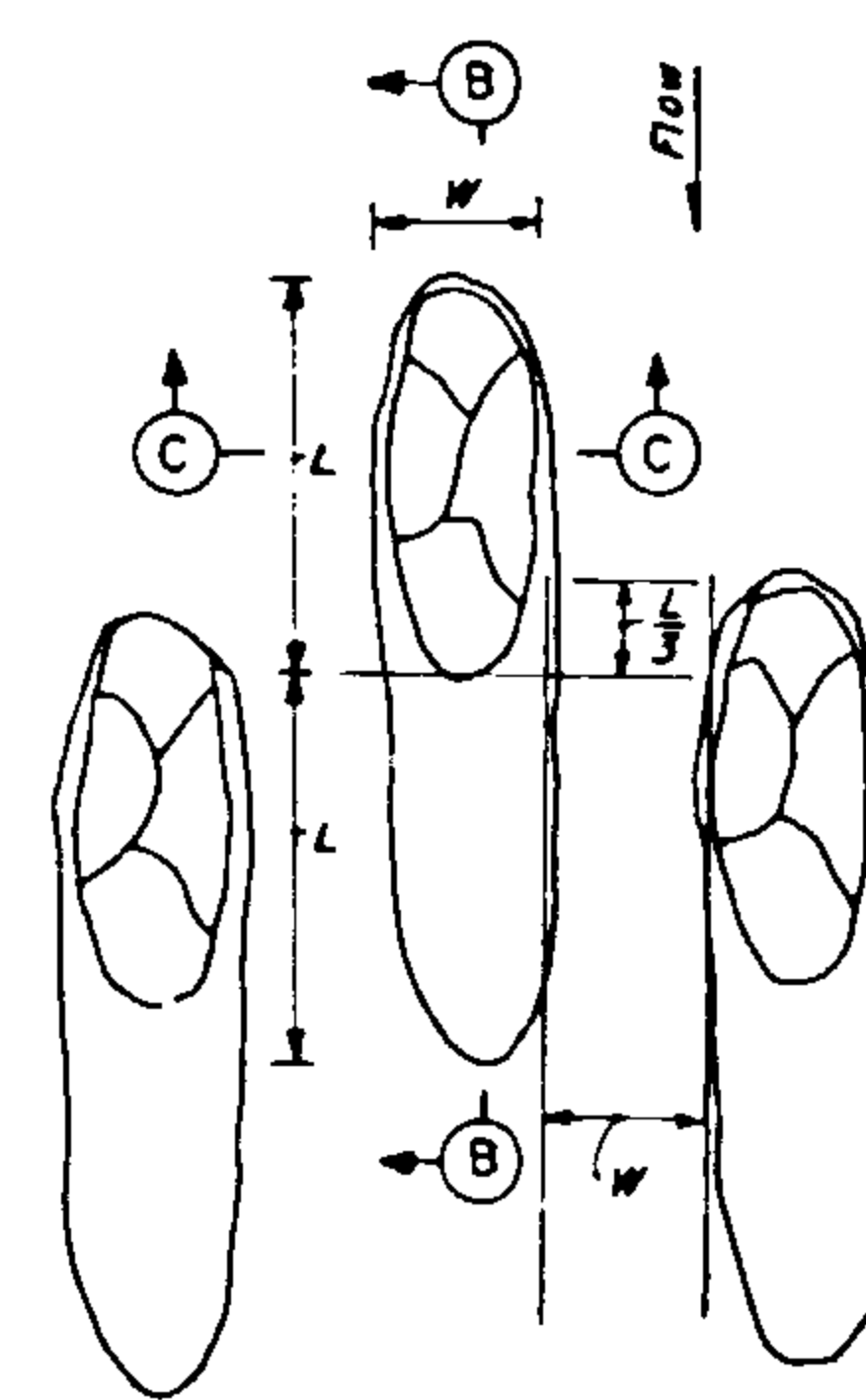

DETAIL A

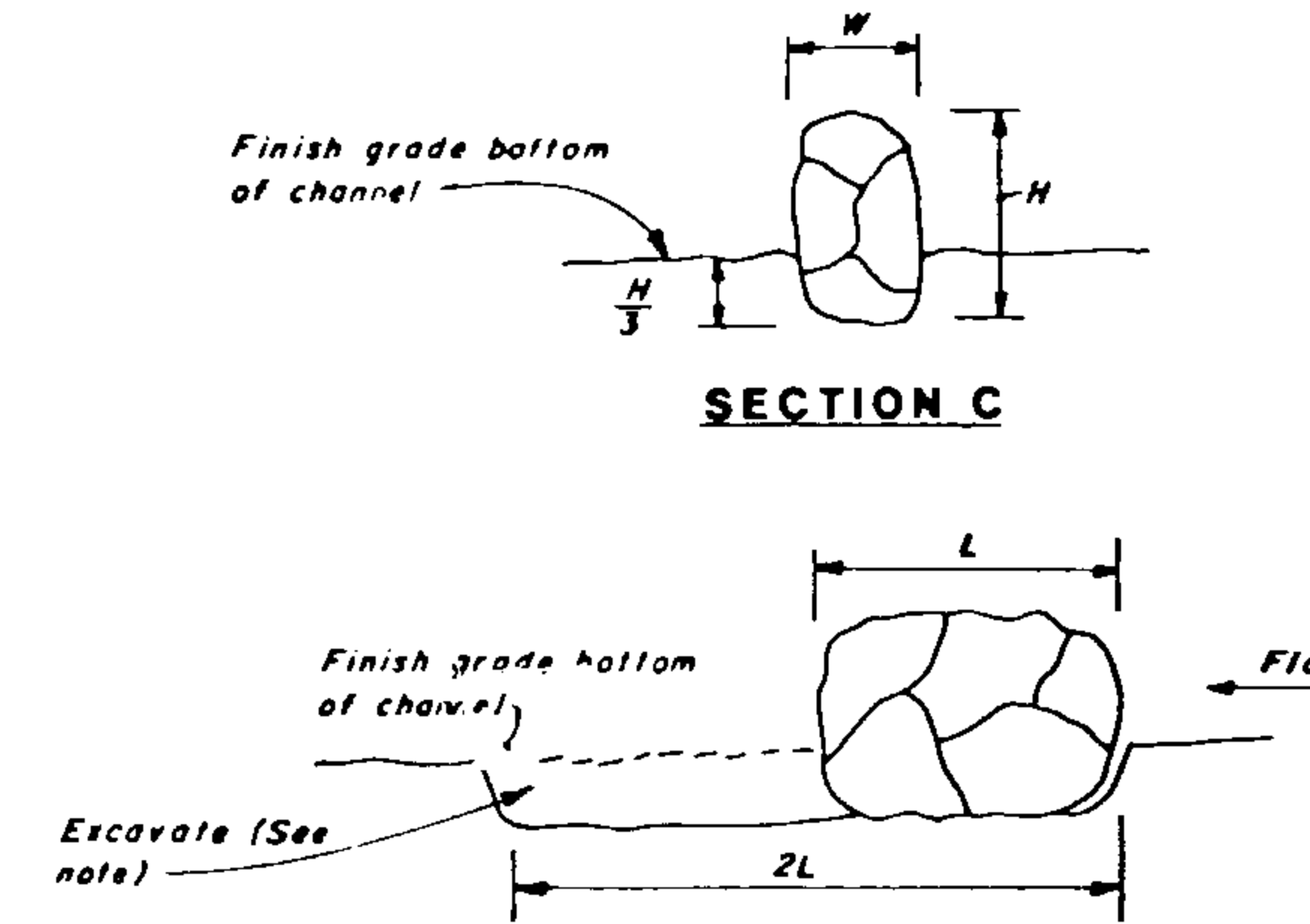

SECTION C

SECTION B

FOR INFORMATION ONLY

REVISION	DATE	DESCRIPTION	BY	CHECKED
A	11/1/88	As Constructed		
B	11/1/88	Minor clarifications		
U. S. ARMY ENGINEER DISTRICT WALLA WALLA, WASHINGTON				
MILL CREEK FLOOD CONTROL PROJECT WALLA WALLA, WASHINGTON				
MILL CREEK CHANNEL REHABILITATION PLACEMENT OF STONES FOR FISH HABITAT				
STA. 323+88 TO STA. 362+80 PLAN, SECTIONS AND DETAILS				
E. Rogers F. Spaulding G. Rogers H. Rogers I. Rogers J. Rogers K. Rogers L. Rogers M. Rogers N. Rogers O. Rogers P. Rogers Q. Rogers R. Rogers S. Rogers T. Rogers U. Rogers V. Rogers W. Rogers X. Rogers Y. Rogers Z. Rogers		3.1 MC-1-90/3.1		

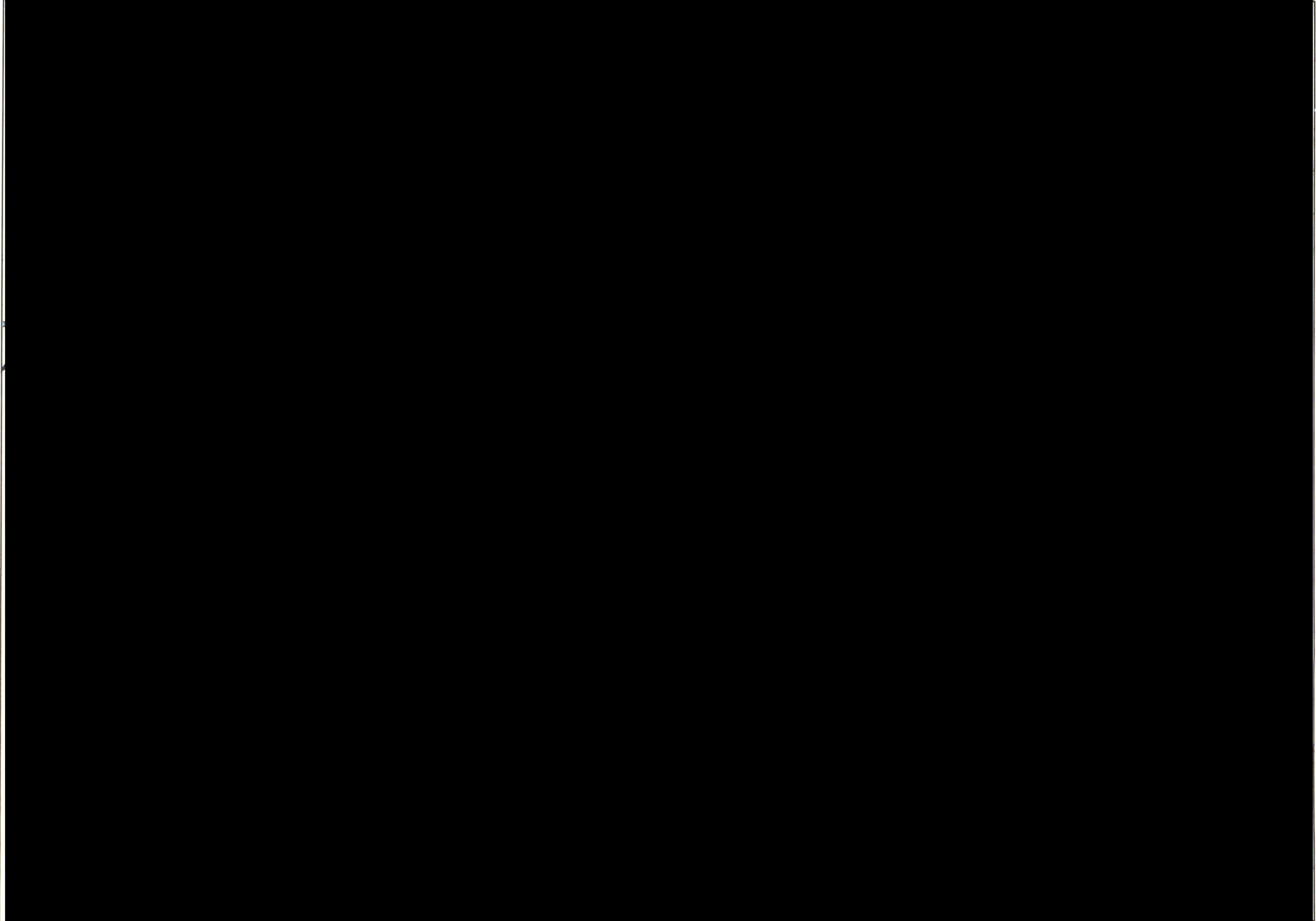

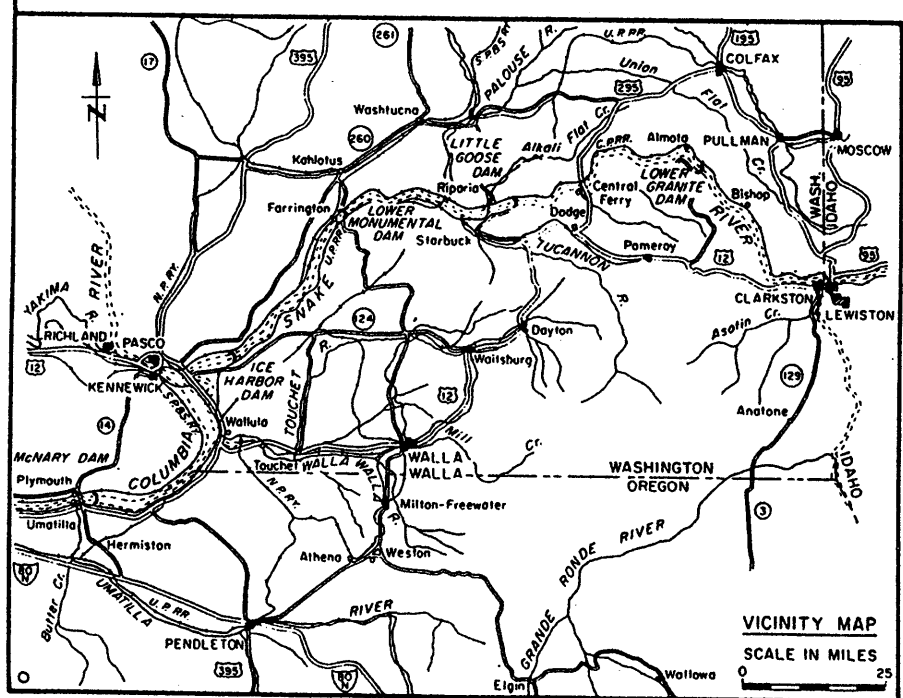
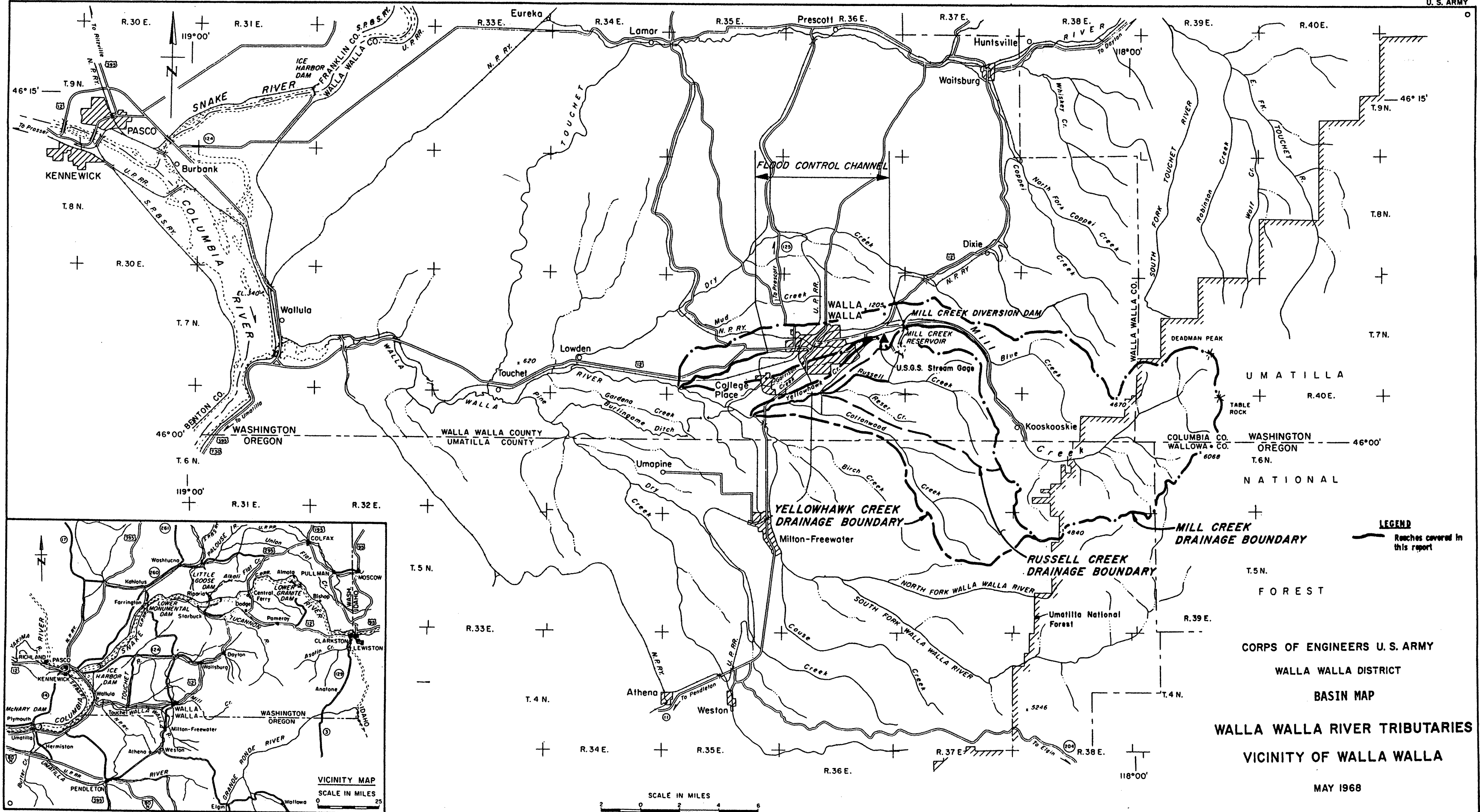

LEGEND
 --- Reaches covered in this report

CORPS OF ENGINEERS U. S. ARMY
 WALLA WALLA DISTRICT
 BASIN MAP
 WALLA WALLA RIVER TRIBUTARIES
 VICINITY OF WALLA WALLA

MAY 1968

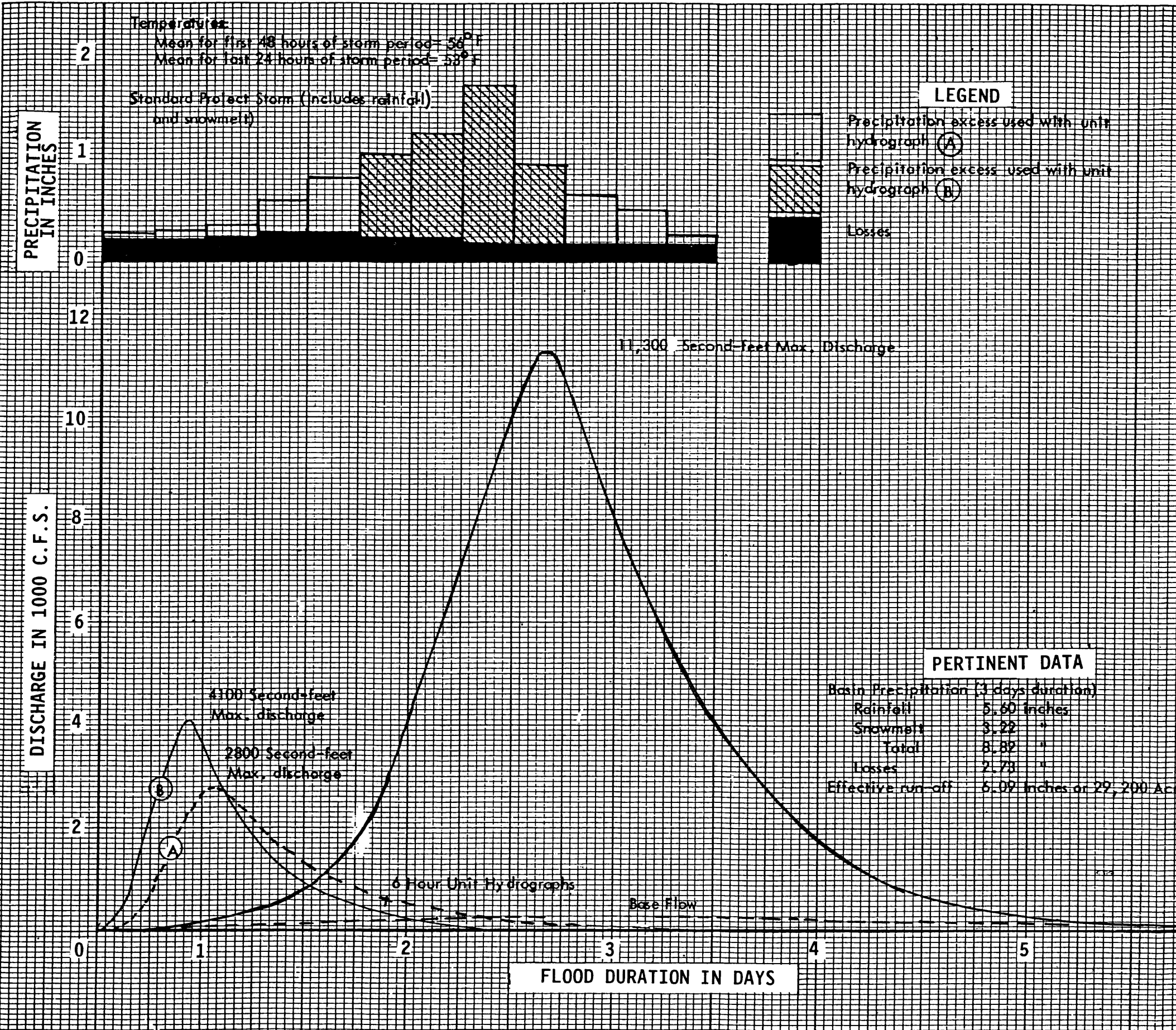

- NOTES:**
1. The Standard Project Flood For Mill Creek at Main Diversion Dam was derived in accordance with instructions from Office Chief of Engineers "Circular 4262, dated 20 November 1946".
 2. The Corps of Engineers terminology of Standard Project Flood refers to a synthetic flood derived from a combination of maximum observed meteorological and hydrological conditions that contribute to a major flood within the basin.
 3. The maximum observed storm occurred on the last of March and first of April 1931 and resulted in one of the largest floods on Mill Creek at Walla Walla, Washington.
 4. Maximum observed temperatures for the last of March occurred in 1934.
 5. Snow cover extending down to an elevation of 3000 feet was used in determining the snow contribution to the flood. Records indicate this assumption to represent maximum snow conditions on the first of April.

FLOOD REGULATION MANUAL
 MILL CREEK RESERVOIR
 WALLA WALLA, WASHINGTON
 DERIVATION OF STANDARD
 PROJECT FLOOD
 WALLA WALLA DISTRICT, CORPS OF ENGRS
 HYDROLOGY AND HYDRAULICS SECTION
 PREPARED: D.E.P. DATE: 4-2-53
 CHECKED: TRACED;

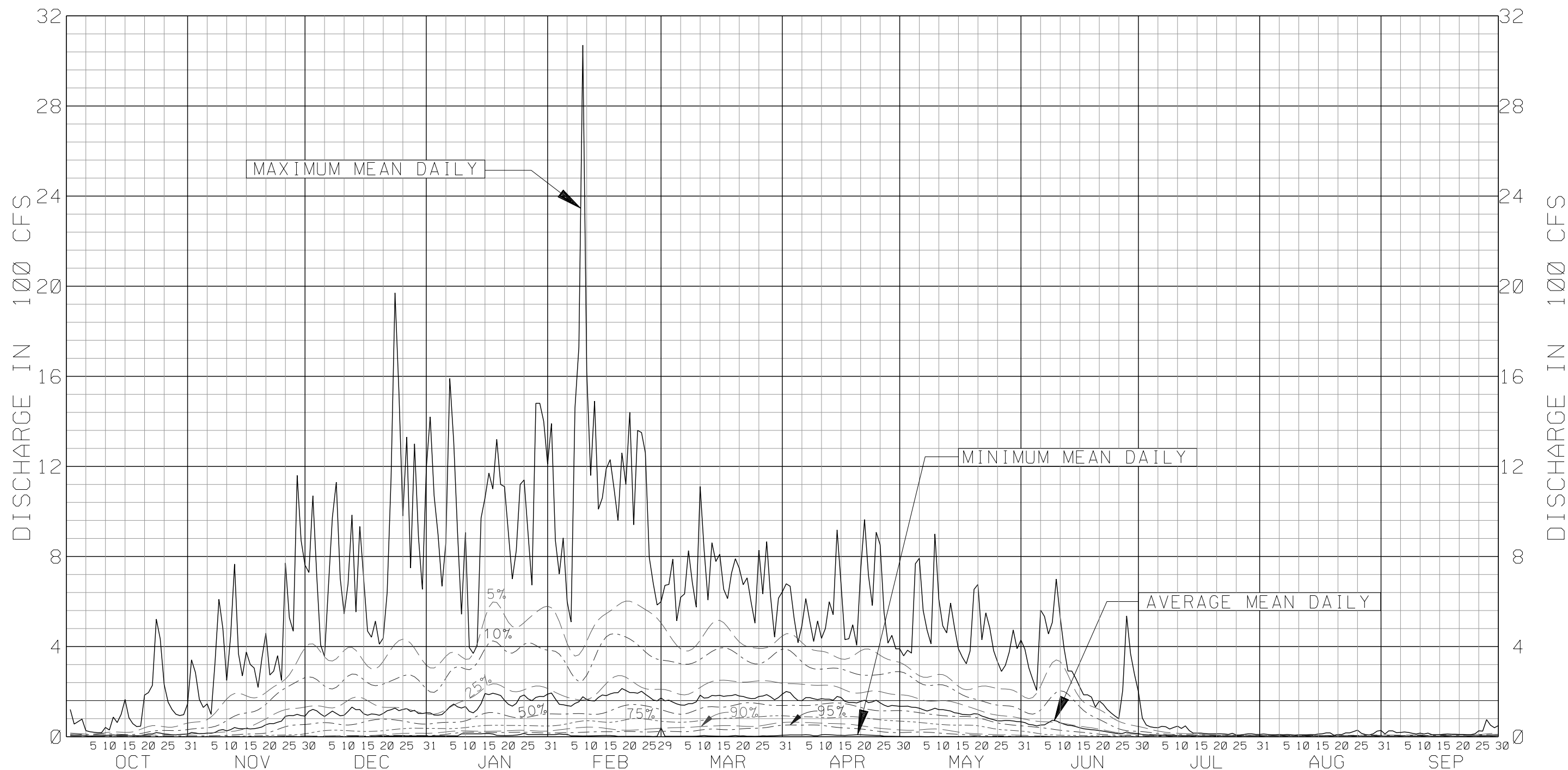

NOTES:

1. PERIOD OF RECORD: WATER YEARS 1942-2005.
2. DRAINAGE AREA: 95.7 SQUARE MILES.
3. U.S.G.S. GAGING STATION NUMBER 14015000.
4. EXCEEDENCE LINES REPRESENT THE PERCENTAGE OF TIME THE FLOW IS EQUALLED OR EXCEEDED ON A GIVEN DAY.

MILL CREEK BASIN
AT WALLA WALLA, WA

SUMMARY HYDROGRAPH

U.S. ARMY ENGINEER DISTRICT
WALLA WALLA - HYDROLOGY SECTION

A00966 HEITSTUMAN

AUGUST 2006

14015000

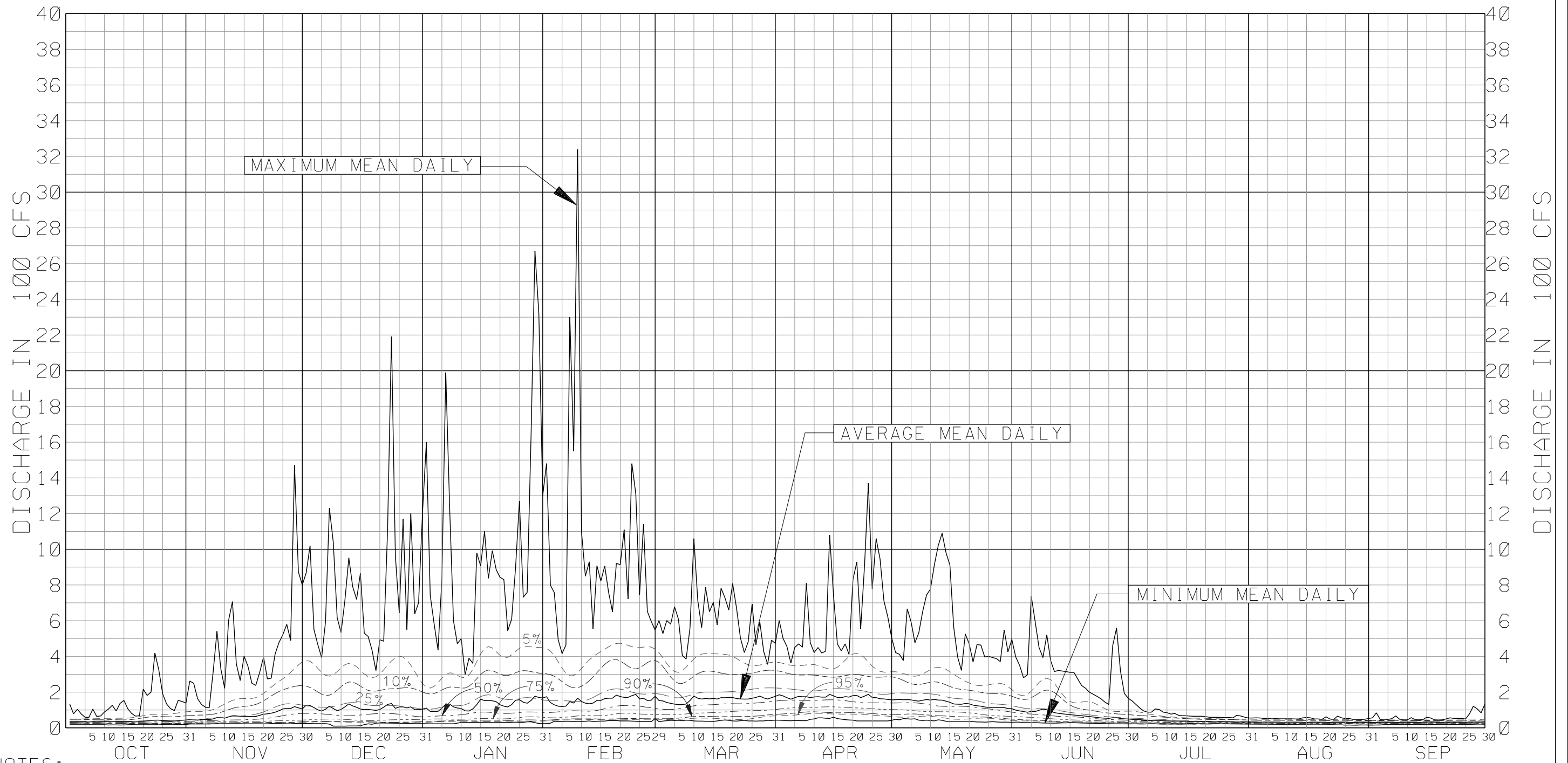

NOTES:

1. PERIOD OF RECORD: WATER YEARS 1914-1917, 1940-1976 AND 1980-2005.
2. DRAINAGE AREA: 59.6 SQUARE MILES.
3. U.S.G.S. GAGING STATION NUMBER 14013000.
4. EXCEEDENCE LINES REPRESENT THE PERCENTAGE OF TIME THE FLOW IS EQUALLED OR EXCEEDED ON A GIVEN DAY.

MILL CREEK BASIN
NEAR WALLA WALLA, WA

SUMMARY HYDROGRAPH

U.S. ARMY ENGINEER DISTRICT
WALLA WALLA - HYDROLOGY SECTION

A00967
HEITSTUMAN
AUGUST 2006

14013000

NOTES:

1. MILL CREEK ANNUAL PEAK DISCHARGE FREQUENCY CURVE FOR U.S.G.S GAGE #14015000 WAS DEVELOPED BY KEVAN SCHNEIDMILLER, JULY 20, 2006. THE CURVE WAS DEVELOPED USING AN EXPECTED PROBABILITY ADJUSTMENT FOR DATA BETWEEN 1942 THROUGH 2005 ALONG WITH THE 1906 AND 1931 HISTORICAL FLOOD EVENTS.
2. THE REGULATED FREQUENCY CURVE WAS DEVELOPED BY KEVAN SCHNIEDMILLER, JUNE 2008. HE REGULATED THE 1996 FLOOD HYDROGRAPH BY SCALING THE HYDROGRAPH ORDINATES TO REPLICATE THE RELATED FLOOD FREQUENCY AND APPLIED THE FLOOD CONTROL RULE CURVE ON CHART 7-1 OF THE WATER CONTROL MANUAL. THE STARTING POOL ELEVATION WAS ASSUMED TO BE 1205 FEET M.S.L.

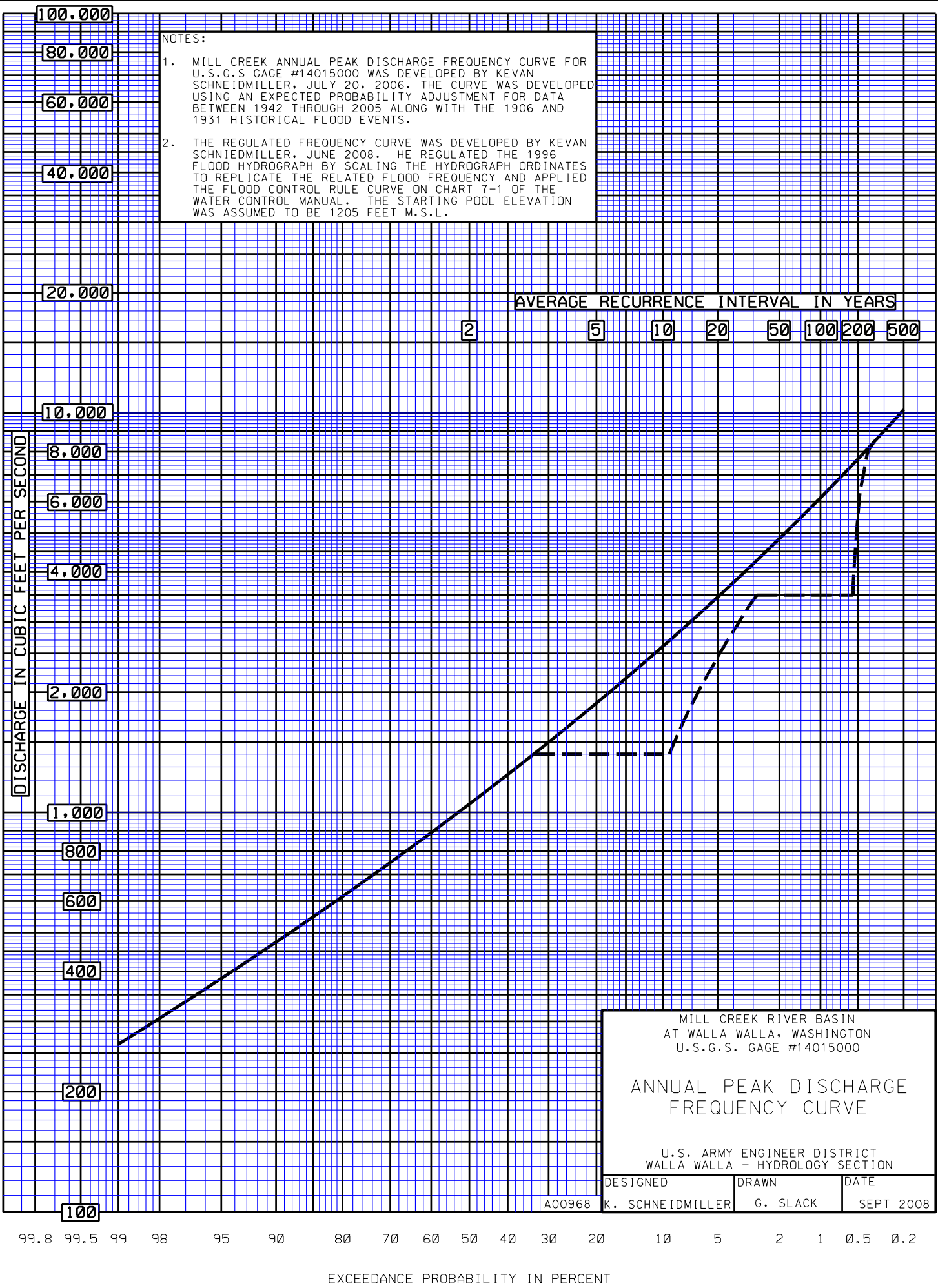

MILL CREEK RIVER BASIN
 AT WALLA WALLA, WASHINGTON
 U.S.G.S. GAGE #14015000

ANNUAL PEAK DISCHARGE
 FREQUENCY CURVE

U.S. ARMY ENGINEER DISTRICT
 WALLA WALLA - HYDROLOGY SECTION

DESIGNED	DRAWN	DATE
K. SCHNEIDMILLER	G. SLACK	SEPT 2008

A00968

EXCEEDANCE PROBABILITY IN PERCENT

EXHIBITS

No.

1-1 Mill Creek Project, Washington - Design Memorandums

MILL CREEK PROJECT, WASHINGTON
DESIGN MEMORANDUMS

<u>No.</u>	<u>Cover Date</u>
1 Master Plan for Mill Creek Reservoir	May 1961
2 Recreation Facilities	February 1962
Supplement 1, Vault-Type Toilet	May 1965
3 Rehabilitation Reservoir Outlet Canal to Mill Creek	June 1973
Letter Supp. 1, Rehabilitation of Outlet Canal to Mill Creek	January 1976
 Unnumbered - Plan of Study	
4 GDM - Project Rehabilitation	August 1979
Letter Supp. 1, Fish and Wildlife Mitigation	October 1981
Letter Supp. 2, Rehabilitation of Return Canal to Mill Creek	April 1982
Letter Supp. 3, Fiber-Reinforced Shotcrete Hard Surface Lining for the Return Canal	
Letter Supp. 4, Combined Risk Analysis	November 1985
Supplement 1, Fish Passage Facility - Mill Creek	January 1981
	Revised August 1981
Supplement 2, Post construction Seepage	
5 Storage Dam Rehabilitation	February 1980
Letter Supp. 1, Embankment Facing	September 1982
6 Main Channel Rehabilitation	December 1982
7 Concrete Aggregate Investigation	May 1982